

Holly Gray, Mayor Pro-Tem  
David Brundage, Councilmember  
John Pullen, Councilmember



Brian Darby, Councilmember  
David Thompson, Councilmember  
Ernie Adams, Councilmember

## ROANOKE CITY COUNCIL AGENDA REGULAR MEETING

**JUNE 23, 2026  
7:05 PM  
500 S. OAK STREET  
ROANOKE, TEXAS 76262**

**A. CALL CITY COUNCIL TO ORDER**

Invocation and Pledge of Allegiance

**B. ANNOUNCEMENTS**

**C. PRESENTATION**

1. Sally Aldridge, President and CEO of the Metroport Chamber, will present the Metroport Chamber Annual Report.

**D. PUBLIC INPUT**

This item is available for citizens to address the City Council on any issues that are not the subject of a public hearing. No action by law may be taken on the topic. The presiding officer reserves the right to impose a time limit on this portion of the agenda. In order to provide the highest quality audio, all speakers need to speak at the podium.

**E. CONSENT AGENDA**

All items listed below are considered routine and will be enacted with one motion. There will be no separate discussion of items unless a Councilmember or citizen so requests, in which event the item will be removed and considered separately.

1. Consider approval of the minutes from the regular City Council meeting held on June 9, 2026.



**AGENDA FOR THE MEETING  
OF THE ROANOKE CITY COUNCIL**

**June 23, 2026  
Page 2 of 4**

2. Consideration and action on approval of Ordinance No. 2026-127, approving the 2024 edition of the International Energy Conservation Code and local amendments thereto.
3. Consideration and action on approval of Ordinance No. 2026-128, approving the 2024 edition of the International Existing Building Code and local amendments thereto.
4. Consideration and action on approval of Ordinance No. 2026-129, approving the 2024 edition of the International Fuel Gas Code and local amendments thereto.
5. Consideration and action on approval of Ordinance No. 2026-130, approving the 2024 edition of the International Mechanical Code and local amendments thereto.
6. Consideration and action on approval of Ordinance No. 2026-131, approving the 2024 edition of the International Plumbing Code and local amendments thereto.
7. Consideration and action on approval of Ordinance No. 2026-132, approving the 2024 edition of the International Property Maintenance Code and local amendments thereto.
8. Consideration and action on approval of Ordinance No. 2026-133 approving the 2024 edition of the International Residential Code and local amendments thereto.
9. Consideration and action on approval of Ordinance No. 2026-134, approving the 2024 edition of the International Swimming Pool and Spa Code and local amendments thereto.
10. Consideration and action on approval of Ordinance No. 2026-135, approving the 2024 edition of the National Electrical Code and local amendments thereto.
11. Consideration and action on approval of Ordinance No. 2026-136, approving the 2024 edition of the International Building Code and local amendments thereto.

**F. NEW BUSINESS**



**AGENDA FOR THE MEETING  
OF THE ROANOKE CITY COUNCIL**

**June 23, 2026  
Page 3 of 4**

1. Consider and act on Resolution No. 2026-113R approving a resolution of the Roanoke Convention Center Hotel Local Development Corporation authorizing the issuance of the Corporation's hotel revenue bonds; approving execution and delivery of all agreements and documents related to the development, construction and operation of the convention center hotel project; and enacting other provisions relating to the subject.
2. Consider and act on Ordinance No. 2026-137 authorizing the issuance of certificates of obligation; delegating the authority to certain city officials to execute certain documents relating to the sale of the certificates; approving and authorizing an official statement and instruments and procedures relating to said certificates; and enacting other provisions relating to the subject.
3. Consider and act on Ordinance No. 2026-138 authorizing the issuance of general obligation bonds; delegating the authority to certain city officials to execute certain documents relating to the sale of the bonds; approving and authorizing an official statement and instruments and procedures relating to the bonds; and enacting other provisions relating to the subject.
4. Consideration and action to appoint three (3) members to the Zoning Board of Adjustments for a term expiring June 2028.
5. Conduct a public hearing and consider approval on Ordinance No. 2026-126 Chapter 12, Article II, Division 3 and Division 4 to increase the number of alternate members for the Planning and Zoning Commission and the Zoning Board of Adjustment.

**G. EXECUTIVE SESSION**

The City Council reserves the right to adjourn into Executive Session during the course of this meeting to discuss any item on the posted agenda as authorized by Chapter 551 of the Texas Government Code.

**H. ADJOURNMENT**

**CERTIFICATION**

I certify that the above notice was posted at City Hall, 500 South Oak Street, Roanoke, Texas, on Tuesday, June 16, 2026, by 5:00 pm, in accordance with Chapter 551, Texas Government Code.



AGENDA FOR THE MEETING  
OF THE ROANOKE CITY COUNCIL

June 23, 2026  
Page 4 of 4

---

Lindsay Rawlinson, City Secretary

\*Any person planning to attend this meeting that may require auxiliary aids or services should request accommodations two (2) days prior to the meeting by calling (817) 491-8152. **BRILLE IS NOT AVAILABLE.**

A public wireless network is now available in the Council Chambers for use during meetings. It is available from 7am to 11pm Monday thru Friday. The name of the network is: COR-Guests



Holly Gray, Mayor Pro-Tem  
David Brundage, Council Member  
John Pullen, Council Member

Carl E. Gierisch, Jr., Mayor

Brian Darby, Council Member  
David Thompson, Council Member  
Ernie Adams, Council Member

**MINUTES  
ROANOKE CITY COUNCIL  
REGULAR MEETING  
JUNE 9, 2026  
CITY HALL COUNCIL CHAMBERS  
500 S. OAK STREET  
7:00 P.M.**

**PRESENT:** Mayor Carl E. "Scooter" Gierisch, Jr., Council Members: Brian Darby, David Brundage, and Ernie Adams; City Manager Cody Petree, Assistant City Manager Jeriahme Miller, City Secretary Lindsay Rawlinson, and City Attorney Jeff Moore.

**DEPT. STAFF:** Finance Director Kyle Lester, Economic Development Manager Siale Langi, Public Engagement Manager Sandra Pettigrew, and City Planner Ashlie Tolliver.

**ABSENT:** Mayor Pro Tem Holly Gray, Council Members: David Thompson and John Pullen

**A. CALL CITY COUNCIL TO ORDER**

Mayor Gierisch called the meeting to order at 7:00 p.m.

Invocation and Pledge of Allegiance given by Mayor Gierisch.

**B. ANNOUNCEMENTS**

City Manager Cody Petree announced a community meeting to allow for public input regarding the Downtown Master Plan will be held Tuesday, July 14, 2026.

**C. PUBLIC INPUT**

None.

**D. CONSENT AGENDA**

All items listed below are considered routine and will be enacted with one motion. There will be no separate discussion of items unless a Councilmember or citizen so requests, in which event the item will be removed and considered separately.

1. Consider approval of the minutes from the special called canvassing meeting and regular City Council meeting, both held on May 26, 2026.
2. Consider and take action on Ordinance No. 2026-125, providing for a reasonable limit on



MINUTES FOR THE REGULAR MEETING  
OF THE ROANOKE CITY COUNCIL

June 9, 2026  
Page 2 of 5

the amount of time to be spent without charge for repeat open records requestors.

Motion made by Council Member Brundage and seconded by Council Member Adams to approve the Consent Agenda.

Motion carried unanimously.

**E. OLD BUSINESS**

1. Consider approval to award a bid to Dickerson Construction Company, Inc. for waterline improvements on Highway 377, including the installation of a new waterline crossing Highway 377, completing a loop in the system by connecting the Westside waterlines to the Eastside waterlines, for an amount not to exceed \$110,550.00.

Motion made by Council Member Adams and seconded by Council Member Brundage to approve award a bid to Dickerson Construction Company, Inc. for waterline improvements on Highway 377, including the installation of a new waterline crossing Highway 377, completing a loop in the system by connecting the Westside waterlines to the Eastside waterlines, for an amount not to exceed \$110,550.00.

Motion carried unanimously.

2. Notice of Withdrawal of Application by Kevin Kriston of Texas Lehigh Cement Co., LP, to amend the comprehensive zoning ordinance of the City of Roanoke, Texas, for Block 33, 38, and 39 of the OT Roanoke Addition, an addition to the City of Roanoke, Denton County, Texas, by changing the zoning on said tract of land from Business Park to Business Park - Specific Use Permit (SUP) to allow the installation of equipment to a new maximum height of 150'. The property is generally located at 400 US Hwy 377. (SUP-2026-01, Ordinance No. 2026-101)

The applicant has rescinded the application; therefore, no action by the City Council is required.

**F. NEW BUSINESS**

1. **Consider and take action** on a Site Plan request by Christopher Webb, on behalf of Scout Cold Storage Roanoke, L.P., for an Albertsons Warehouse to be located on a portion of an approximately 128.294 acre parcel on Lot 1, Block 1, Alliance-Gateway Food Lion, an addition to the City of Roanoke, Denton County, Texas. The property is addressed as 743 Henrietta Creek Parkway. (SP-2026-04)

The proposed site plan is located on an approximately 128.294 acre parcel. The property is zoned Business Park and the proposed use is a 31,714 square foot warehouse with truck docks on both the northern and southern facades of the structure. There are existing warehouse uses on the property. The addition of the proposed warehouse does not impact any city development standards, and all standards are met.



MINUTES FOR THE REGULAR MEETING  
OF THE ROANOKE CITY COUNCIL

June 9, 2026  
Page 3 of 5

On May 18, 2026, the Planning & Zoning Commission voted to recommend approval of the site plan.

Motion made by Council Member Brundage and seconded by Council Member Adams to approve a Site Plan request by Christopher Webb, on behalf of Scout Cold Storage Roanoke, L.P., for an Albertsons Warehouse to be located on a portion of an approximately 128.294 acre parcel on Lot 1, Block 1, Alliance-Gateway Food Lion, an addition to the City of Roanoke, Denton County, Texas. The property is addressed as 743 Henrietta Creek Parkway. (SP-2026-04)

Motion carried unanimously.

2. **Consider and take action** on a Site Plan request by Sandy Brantley, on behalf of QuikTrip Corporation, for a Quik Trip to be located on an approximately 6.168-Acre tract located in the W.Beall Survey, Abstract No. 82, City of Roanoke, Denton County, Texas. The property is generally located at the northeast corner of the intersection of US Hwy 377 and Bobcat Blvd. (SP-2026-03).

Sandy Brantley, on behalf of Quik Trip Corporation, is requesting approval of a site plan for a Quik Trip Gasoline Station, proposed to be located on a 6.168-Acre tract generally located at the northeast corner of the intersection of US Hwy 377 and Bobcat Boulevard. The property is zoned "R" - Retail, and the proposed use is permitted by right. The store is proposed to be 6,445 square feet, and will also have 16 gasoline pump stations.

The applicant is proposing two attached signs on the front elevation. The total area of signage on the front elevation would be approximately 200 square feet. While they are requesting two attached signs, the total sign area proposed is 98 square feet less than the maximum sign area allowed based on the facade area. The south side elevation has road frontage along Bobcat Boulevard, and is allowed by right to have a total sign area of approximately 164 square feet. The applicant is proposing one sign, of approximately 57 square feet.

While the applicant is requesting a total of three attached signs, one more than what is allowed by right, the aggregate total of proposed sign area is still significantly less than what would be allowed if the applicant was proposing one large sign per road frontage facade.

On June 1, 2026, Planning & Zoning voted to recommend approval of the Site Plan with the condition that City Council review the signage.

Motion made by Council Member Darby and seconded by Council Member Brundage to approve a Site Plan request by Sandy Brantley, on behalf of QuikTrip Corporation, for a Quik Trip to be located on an approximately 6.168-Acre tract located in the W.Beall Survey, Abstract No. 82, City of Roanoke, Denton County, Texas. The property is generally located at the northeast corner of the intersection of US Hwy 377 and Bobcat Blvd. (SP-2026-03).

Motion carried unanimously.



**MINUTES FOR THE REGULAR MEETING  
OF THE ROANOKE CITY COUNCIL**

**June 9, 2026  
Page 4 of 5**

3. Consideration and action on approval of a façade grant application Greg Polson of the Roanoke Tavern located at 309 South Oak Street, Roanoke, TX 76262.

A façade grant application was received and reviewed by staff for improvements to the subject property for the full amount allowed by the City's grant policy: \$15,000. The estimated cost of improvements to the exterior of the property is \$42,076.

The improvements include the installation of a metal pergola to cover the existing outdoor seating area, a privacy fence, and the installation of patio heaters.

This will be the sixth grant approved and awarded during the current fiscal year.

Motion made by Council Member Brundage and seconded by Council Member Adams to approve a façade grant application Greg Polson of the Roanoke Tavern located at 309 South Oak Street, Roanoke, TX 76262.

Motion carried unanimously.

4. Consideration and action on approval of Amendment #03 to a Design Build Agreement (DBA) by and between Roanoke Convention Center Hotel Local Development Corporation and Brasfield & Gorrie for the balance of the Guaranteed Maximum Price (GMP) contract to enable Brasfield & Gorrie to proceed with the work for the full build out of the Hotel & Convention Center in the amount of \$97,560,722 for a total GMP value of \$103,779,047.

Motion made by Council Member Darby and seconded by Council Member Adams to approve Amendment #03 to a Design Build Agreement (DBA) by and between Roanoke Convention Center Hotel Local Development Corporation and Brasfield & Gorrie for the balance of the Guaranteed Maximum Price (GMP) contract to enable Brasfield & Gorrie to proceed with the work for the full build out of the Hotel & Convention Center in the amount of \$97,560,722 for a total GMP value of \$103,779,047.

Motion carried unanimously.

**G. EXECUTIVE SESSION**

The City Council held a closed Executive Session meeting pursuant to the provisions of Chapter 551 of the Texas Government Code, in accordance with the authority contained in:

**Section 551.087**

To deliberate commercial or financial information the City has received from a business prospect, and to deliberate the offer of a financial or other incentive to a business prospect.

-Oak Street Cafe

City Council convened into closed session at 7:10 p.m. and reconvened into regular session at 7:22 p.m.



**MINUTES FOR THE REGULAR MEETING  
OF THE ROANOKE CITY COUNCIL**

**June 9, 2026  
Page 5 of 5**

Motion made by Council Member Brundage and seconded by Council Member Darby to approve a Chapter 380 Agreement with Black Eagle Investors, LLC, on the terms as discussed in executive session.

Motion carried unanimously.

**H. ADJOURNMENT**

Motion made by Council Member Brundage and seconded by Council Member Darby to adjourn the meeting at 7:23 p.m.

Motion carried unanimously.

---

Carl E. "Scooter" Gierisch, Jr., Mayor

---

Lindsay Rawlinson, City Secretary



## AGENDA ITEM

TO: Mayor and City Council

SUBJECT: 2024 edition of the International Energy Conservation Code

MEETING DATE: June 23, 2026

DEPARTMENT: Planning

---

### ITEM SUMMARY:

Consideration and action on approval of Ordinance No. 2026-127, approving the 2024 edition of the International Energy Conservation Code and local amendments thereto.

### INFORMATION:

North Central Texas Council of Governments - Regional Codes Coordinating Committee and its five advisory boards conducted multiple meetings to review the latest editions of the model codes and develop regional amendments. Their review and recommendations are endorsed by NCTCOG's Executive Board. NCTCOG encourages jurisdictions in North Central Texas to adopt the following model construction codes along with their respective regional amendments as expeditiously as their local code adoption process will allow.

NCTCOG issued a memorandum to jurisdictions in North Central Texas to adopt the code updates on May 1, 2025.

### STAFF RECOMMENDATION:

Staff recommends approval.

### SPECIAL CONSIDERATION:

### FINANCIAL CONSIDERATION:

ATTACHMENTS:



## AGENDA ITEM

1. Ordinance No. 2026-127 - International Energy Conservation Code - 2024 Edition - with local amendments
2. 2025-Memo-to-Jurisdictions\_Signed-official

**ORDINANCE NO. 2026-127**

**AN ORDINANCE OF THE CITY COUNCIL OF THE CITY OF ROANOKE, TEXAS, AMENDING CHAPTER 3, ARTICLE 3.100 OF THE CODE OF ORDINANCES OF THE CITY OF ROANOKE, TEXAS, ENTITLED “INTERNATIONAL CODES ADOPTED” BY REPEALING IN ITS ENTIRETY SECTION 3.108 ENTITLED “INTERNATIONAL ENERGY CONSERVATION CODE ADOPTED,” AND REPLACING IT WITH A NEW SECTION 3.108 ENTITLED “INTERNATIONAL ENERGY CONSERVATION CODE ADOPTED,” BY ADOPTING THE 2024 EDITION OF THE *INTERNATIONAL ENERGY CONSERVATION CODE*, AND LOCAL AMENDMENTS TO THE *INTERNATIONAL ENERGY CONSERVATION CODE*; PROVIDING A SEVERABILITY CLAUSE; PROVIDING A REPEALER CLAUSE; PROVIDING A PENALTY FOR VIOLATIONS; PROVIDING FOR PUBLICATION IN THE OFFICIAL NEWSPAPER; AND PROVIDING FOR AN EFFECTIVE DATE.**

**WHEREAS**, the City Council of the City of Roanoke, Texas, is of the opinion that the 2024 Edition of the *International Energy Conservation Code*, along with local amendments hereto, should be adopted as the Energy Conservation Code for the City of Roanoke.

**NOW, THEREFORE, BE IT ORDAINED BY THE CITY COUNCIL OF THE CITY OF ROANOKE, TEXAS, THAT:**

**SECTION 1.  
FINDINGS INCORPORATED**

The findings set forth above are incorporated into the body of this Ordinance as if fully set forth herein.

**SECTION 2.  
AMENDMENT**

Chapter 3, Article 3.100, of the Code of Ordinances of the City of Roanoke, Texas, entitled “International Codes Adopted,” is hereby amended by repealing in its entirety Section 3.108 entitled “International Energy Conservation Code Adopted” and replacing it with a new Section 3.108 entitled “International Energy Conservation Code Adopted,” which shall read as follows:

**“Sec. 3.108. International Energy Conservation Code Adopted.**

- (a) *Adoption.* The *International Energy Conservation Code*, 2024 edition, is hereby adopted and designated as the Energy Conservation Code for the City of Roanoke, Texas. A copy of the 2024 Edition of the *International Energy Conservation Code* is on file in the office of the city secretary.

- (b) *Local Amendments.* The following provisions, attached hereto as **Exhibit A** of this Ordinance, are local amendments to the 2024 Edition of the *International Energy Conservation Code*. Each provision in this subsection is a substitute for the identically numbered provision contained in the 2024 Edition of the *International Energy Conservation Code* or is an additional provision added to the 2024 Edition of the *International Energy Conservation Code*.

### **SECTION 3. SEVERABILITY CLAUSE**

It is hereby declared to be the intention of the City Council that the phrases, clauses, sentences, paragraphs and sections of this Ordinance are severable, and if any phrase, clause, sentence, paragraph or section of this Ordinance shall be declared unconstitutional by the valid judgment or decree of any court of competent jurisdiction, such unconstitutionality shall not affect any of the remaining phrases, clauses, sentences, paragraphs and sections of this Ordinance, since the same would have been enacted by the City Council without the incorporation of this Ordinance of any such unconstitutional phrase, clause, sentence, paragraph or section.

### **SECTION 4. REPEALER CLAUSE**

Any provision of any prior ordinance of the City whether codified or uncodified, which are in conflict with any provision of this Ordinance, are hereby repealed to the extent of the conflict, but all other provisions of the ordinances of the City whether codified or uncodified, which are not in conflict with the provisions of this Ordinance, shall remain in full force and effect.

### **SECTION 5. PENALTY CLAUSE**

Any person, firm, or corporation violating any of the provisions or terms of this Ordinance shall be guilty of a misdemeanor and upon conviction, shall be fined a sum not to exceed \$2,000.00 for each offense, and each and every violation or day such violation shall continue or exist, shall be deemed a separate offense.

### **SECTION 6. PUBLICATION CLAUSE**

The City Secretary of the City is hereby directed to publish in the official newspaper of the City the caption, penalty clause, and effective date clause of this Ordinance as required by law.

**SECTION 7.  
EFFECTIVE DATE**

This Ordinance shall become effective immediately upon its passage and publication as required by law.

**PASSED, APPROVED AND ADOPTED** by the City Council of the City of Roanoke, Texas, on this June 23, 2026.

**APPROVED:**

\_\_\_\_\_  
Carl E. Gierisch, Jr., Mayor

**ATTEST:**

\_\_\_\_\_  
Lindsay Rawlinson, City Secretary

**APPROVED AS TO FORM:**

\_\_\_\_\_  
Jeff Moore, City Attorney

## Exhibit A

Local Amendments  
to the  
*International Energy Conservation Code*

**Recommended Amendments to the 2024 International Energy Conservation Code  
and the energy provisions of the 2024 International Residential Code**  
North Central Texas Council of Governments Region  
(Climate Zone 2 & 3 of the IECC)

The following sections, paragraphs, and sentences of the *2021 International Energy Conservation Code* (IECC) are hereby amended as follows: Standard type is text from the IECC. Underlined type is text inserted. Lined through type is deleted text from IECC. A double (\*\*) asterisk at the beginning of a section identifies an amendment carried over from the 2021 edition of the code and a triple (\*\*\*) asterisk identifies a new or revised amendment with the 2024 code. Section numbers in parenthesis represent the corresponding numbers of the energy provisions of the 2021 *International Residential Code* for parallel amendments.

### 2024 IECC (Energy Provisions of the 2024 IRC)

**NOTE:**

*In the case when an AHJ has governance over land in both Climate Zones 2A and 3A, this body recommends that said jurisdiction amends Tables C301.1 and R301.1 accordingly such that the entire area they have jurisdiction over is of the same Climate Zone.*

**\*\*Section C102/R102 General; add Section C102.1.2 and R102.1.2 (N1101.4.1) to read as follows:**

**C104.1.2 Alternative compliance.** A building certified by a national, state, or local accredited energy efficiency program and determined by the Energy Systems Laboratory to be in compliance with the energy efficiency requirements of this section may, at the option of the Code Official, be considered in compliance. The United States Environmental Protection Agency's Energy Star Program certification of energy code equivalency shall be considered in compliance.

**R104.1.2 (N1101.4.1) Alternative compliance.** A building certified by a national, state, or local accredited energy efficiency program and determined by the Energy Systems Laboratory to be in compliance with the energy efficiency requirements of this section may, at the option of the Code Official, be considered in compliance. The United States

Environmental Protection Agency's Energy Star Program certification of energy code equivalency shall be considered in compliance. Regardless of the program or the path to compliance, each 1- and 2-family dwelling shall be tested for air and duct leakage as prescribed in Section R402.5.1.2 (N1102. 5.1.2) and R403.3.7 (N1103.3.7) respectively.

*(Reason: This amendment is added to allow alternative compliance in accordance with Texas HB 1365, 78<sup>th</sup> Legislature. Codified in Chapter 388 Texas Building Energy Performance Standards: §388.003(i).*

*The last sentence to Section R104.1.2 (N1101.4.1) was added to ensure that every house is tested in accordance with the mandatory provisions of the code.)*

**\*\*\*Section C403.7.4.1 Nontransient dwelling units.; amend as follows.**

**C403.7.4.1 Nontransient dwelling units.** Nontransient dwelling units shall be provided with outdoor air energy recovery ventilation systems complying with not less than one of the following:

1. The system shall have an enthalpy recovery ratio of not less than 50 percent at cooling design condition and not less than 60 percent at heating design condition.
2. The system shall have a sensible recovery efficiency (SRE) that is not less than 65 percent at 32°F (0°C) and in Climate Zones 0A, 1A, 2A and 3A shall have a net moisture transfer (NMT) that is not less than 40 percent at 95°F (35°C). SRE and NMT shall be determined from a listed value or from interpolation of listed values at an airflow not less than the design airflow, based on testing in accordance with CAN/CSA C439.

**Exceptions:**

1. Nontransient dwelling units in Climate Zone 3C.
2. Nontransient dwelling units with not more than 500 square feet (46 m<sup>2</sup>) of conditioned floor area in Climate Zones 0, 1, 2, 3, 4C and 5C.
3. Enthalpy recovery ratio requirements at heating design condition in Climate Zones 0, 1 and 2.
4. Enthalpy recovery ratio requirements at cooling design condition in Climate Zones 4, 5, 6, 7 and 8.
5. Dwelling units using ventilation systems per the Fan Efficacy Table in R406, shall be considered in compliance.

**\*\*\*Section C405.2.10 Sleeping unit and dwelling unit lighting and switched receptacle controls; ~~deleted in its entirety.~~**

*(Reason: The requirement for automatic shutoff and switched receptacle controls in sleeping and dwelling units imposes an unnecessary restriction on personal living spaces, where lighting use should be a matter of individual preference rather than mandated control.)*

**\*\*\*Section R105.2.2 Solar Ready System; deleted in entirety.**

*(Reason: Removes ambiguity if Solar Ready provisions are not adopted).*

**\*\*\*Section R106.3 Permit Valuation; deleted in entirety.**

**(Reason: R106.3 no longer applies due to conflict with HB852, 86th Regular Session).**

**Section R202 (N1101.6) Definitions; add the following definition:**

**\*\*DYNAMIC GLAZING.** Any fenestration product that has the fully reversible ability to change its performance properties, including *U*-factor, solar heat gain coefficient (SHGC), or visible transmittance (VT).

*(Reason: This term is referenced in Section R402.4.2. This definition of DYNAMIC GLAZING is also found in the Commercial provisions of the code.)*

**\*\*\* Section R401.2.1 Prescriptive Compliance Option; deleted reference to R408.**

**(Reason: Conflicts with HB2439, 86th Regular Session.)**

**\*\*\*Section R402.2.10 (N1102.2.10) Slab-on-grade floors; amend as follows.**

**Exception:** Slab-edge insulation is not required in jurisdictions designated by the *code official* as having a moderate to heavy or very heavy termite infestation probability.

*(Reason: Termites are an issue of concern throughout the North Central Texas Council of Governments Region which includes areas designated as having a “moderate to heavy” and “very heavy” infestation probability.)*

**\*\*\* Section R402.5.5 (N1102.5.5) Air-sealed electrical and communication outlet boxes; amend as follows.**

**Section R402.5.5 (N1102.5.5) Air-sealed electrical and communication outlet boxes.** Air-sealed electrical and communication outlet boxes that penetrated the *air barrier* of the *building thermal envelope* shall be caulked, taped, gasketed or otherwise sealed to the *air barrier* element being penetrated. Air-sealed boxes shall be buried in or surrounded by insulation. Air-sealed boxes shall be tested and marked in accordance with NEMA OS 4. Air-sealed boxes shall be installed in accordance with the manufacturer’s instructions.

**Exception:** Boxes may be air-sealed in the field using caulk, tape, gasket or other approved method to prevent air leakage through the box in lieu of NEMA OS 4 boxes. Boxes air-sealed in the field shall be sealed to the air barrier element being penetrated and installed in accordance with manufacturer’s instructions

(Reason: Amended to allow on-site air-sealing of electrical and communication boxes in order to meet current building techniques, market conditions and product availability.)

**\*\*\*Table 402.1.2 (1102.1.2) Maximum Assembly/Climate Zone items: amend table as follows.**

**TABLE R402.1.2 (N1102.1.2) - MAXIMUM ASSEMBLY U-FACTOR AND FENESTRATION REQUIREMENTS**

Portions of table not shown remain unchanged.

<b>CLIMATE ZONE</b>	<b>2</b>	<b>3</b>
<b><u>Attic Roofline U-factor<sup>f</sup></u></b>	<b><u>0.035</u></b>	<b><u>0.035</u></b>

f. Air-impermeable insulation located at the attic roofline but below the roof deck may be used if mechanical equipment and air distribution system are located entirely within the building thermal envelope. "Air-impermeable" shall be defined as having an air permeance not exceeding 0.02 L/s-m<sup>2</sup> at 75 Pa pressure differential tested according to ASTM E 2178 or ASTM E 283.

**\*\*\*Table 402.1.3 (N1102.1.3) Insulation/Climate Zone items: amend table as follows.**

**TABLE R402.1.3 (N1102.1.3) - INSULATION MINIMUM R-VALUES AND FENESTRATION REQUIREMENTS BY COMPONENT**

Portions of table not shown remain unchanged.

<b>CLIMATE ZONE</b>	<b>2</b>	<b>3</b>
<b><u>attic roofline R-value<sup>i</sup></u></b>	<b><u>30+0ci</u></b>	<b><u>30+0ci</u></b>

i. Air-impermeable insulation of R-30&0 or greater located at the attic roofline but below the roof deck may be used if mechanical equipment and air distribution system are located entirely within the building thermal envelope. "Air-impermeable" shall be defined as having an air permeance not exceeding 0.02 L/s-m<sup>2</sup> at 75 Pa pressure differential tested according to ASTM E 2178 or ASTM E 283.

(Reason: Amended table to meet current building techniques, market conditions and product availability.)

**\*\*\*Section R404.2 (N1104.2) Interior lighting controls; deleted in its entirety.**

(Reason: The requirement for automatic shutoff and switched receptacle controls in sleeping and dwelling units imposes an unnecessary restriction on personal living spaces, where lighting use should be a matter of individual preference rather than mandated control.)

**\*\*\* TABLE R405.4.2(1) (N1105.4.2(1)) - SPECIFICATIONS FOR THE STANDARD REFERENCE AND PROPOSED DESIGNS: amend table as follows.**

**TABLE R405.4.2(1) (N1105.4.2(1)) SPECIFICATIONS FOR THE STANDARD REFERENCE AND PROPOSED DESIGNS**

Portions of table not shown remain unchanged.

BUILDING COMPONENT	STANDARD REFERENCE DESIGN	PROPOSED DESIGN
Foundations	Type: same as proposed.	As proposed
	Foundation wall or slab extension above grade: 1 foot (30cm) Foundation wall or slab extension below grade: same as proposed Foundation wall or slab perimeter length: same as proposed Soil characteristics: same as proposed.	As proposed
	Foundation wall U-factor and slab-on-grade F-factor: as specified in Table R402.1.2. <sup>n</sup>	As proposed

For SI: 1 square foot = 0.93 m<sup>2</sup>, 1 British thermal unit = 1055 J, 1 pound per square foot = 4.88 kg/m<sup>2</sup>, 1 gallon (US) = 3.785 L, °C = (°F-32)/1.8, 1 degree = 0.79 rad.

n. In accordance with Section R402.2.10, a maximum F-factor of 0.73 shall apply for the reference design in jurisdictions designated by the code official as having a moderate to heavy or very heavy termite infestation probability.

(Reason: Termites are an issue of concern throughout the North Central Texas Council of Governments Region which includes areas designated as having a “moderate to heavy” and “very heavy” infestation probability.)

**\*\*TABLE R406.5 (N1106.5) MAXIMUM ENERGY RATING INDEX; amend to read as follows:**

**TABLE R406.5 (N1106.5) <sup>2</sup>  
MAXIMUM ENERGY RATING INDEX**

CLIMATE ZONE	ENERGY RATING INDEX NOT INCLUDING OPP	ENERGY RATING INDEX WITH OPP
2	54 59	34
3	50 59	33

<sup>2</sup> The table is effective from September 1, 2022 to August 31, 2025.

**TABLE R406.5 (N1106.5) <sup>3</sup>  
MAXIMUM ENERGY RATING INDEX**

CLIMATE ZONE	ENERGY RATING INDEX NOT INCLUDING OPP	ENERGY RATING INDEX WITH OPP

2	54 57	34
3	50 57	33

<sup>3</sup> The table is effective from September 1, 2025 to August 31, 2028.

**TABLE R406.5 (N1106.5) <sup>4</sup>  
MAXIMUM ENERGY RATING INDEX**

CLIMATE ZONE	ENERGY RATING INDEX NOT INCLUDING OPP	ENERGY RATING INDEX WITH OPP
2	54 55	34
3	50 55	33

<sup>4</sup> This table is effective on or after September 1, 2028.

*(Reason: The tables reflect the values and timetable set forth in HB 3215, 87<sup>th</sup> Regular Session Codified in Chapter 388 Texas Building Energy Performance Standards: §388.003.)*

**\*\*\* Section R408 Additional Efficiency Requirements; deleted in entirety.**

*(Reason: The deletion is based on the omission of reference to R408 in R401.2.1, and R408 conflicts with HB2439, 86th Regular Session.)*

**NOTE :** HB 3215 was signed into law by the Governor on June 14, 2021 as part of the 87<sup>th</sup> Regular Session Codified in Chapter 388 Texas Building Energy Performance Standards: §388.003 (i), (j), and (k). HB 3215 now allows a **Home Energy Rating System Index (ex. HERS Index)** utilizing ANSI/RESNET/ICC Standard 301 (as it existed on January 1, 2021) shall be considered in compliance with State law provided that:

- o The home includes compliance with the Mandatory requirements of 2018 IECC Section R406.2.
- o The home includes compliance with Building thermal envelope provisions of Table R402.1.2 or Table R402.1.4 of the 2018 IECC

**END**

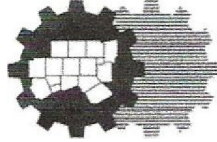

North Central Texas Council of Governments

**TO:** Mayors, City Managers, City Administrators,  
County Judges, and Building Officials

**DATE:** May 1, 2025

**SUBJECT:** 2024 International Codes and Regional Code Amendments for North Central Texas

The North Central Texas Council of Governments (NCTCOG) Executive Board, upon recommendation of the Regional Codes Coordinating Committee (RCCC) and its Advisory Boards, endorsed the most recent regional amendments to several of the 2024 International Codes on March 27, 2025. The Executive Board encourages your jurisdiction to adopt the following 2024 International Codes and Regional Amendments:

- International Building Code
- International Energy Conservation Code
- International Fuel Gas Code
- International Mechanical Code
- International Plumbing Code
- International Residential Code
- International Swimming Pool and Spa Code
- 2023 National Electric Code (approved August 2023)

NCTCOG's RCCC recommends adopting the above-listed codes with no local amendments, other than the regional amendments, as expeditiously as possible. The 2024 International Fire Code (IFC) with recommended regional amendments will be brought forward for regional endorsement in the very near future. The ultimate goal is regional uniformity of building codes for the North Central Texas region. Achieving the goal of standardization of building codes across the region will result in positive economic impacts and other benefits for municipalities, contractors, architects, builders, and manufacturers.

NCTCOG appreciates your local government's support of our continued efforts toward regional code uniformity. To learn more about the regional codes work program, or to obtain a copy of the recommended regional amendments, you may access our website at <https://www.nctcog.org/envir/regional-building-codes/amendments>.

If you would like to financially contribute to the Regional Codes Work Program, or have any questions regarding regional codes, please contact Hannah Ordonez, Senior Environment & Development Planner, by email at [hordonez@nctcog.org](mailto:hordonez@nctcog.org) or by phone at (817) 695-9215.

We appreciate your support of our continued efforts toward regional code uniformity.

  
[Mike Eastland](#) (May 13, 2025 13:28 CDT)  
Mike Eastland, Executive Director, NCTCOG

  
David Kerr, RCCC Chair

**616 Six Flags Drive, Centerpoint Two**  
**P.O. Box 5888, Arlington, Texas 76005-5888**  
**(817) 640-3300 FAX: 817-640-7806**  
**[www.nctcog.org](http://www.nctcog.org)**



## AGENDA ITEM

TO: Mayor and City Council

SUBJECT: 2024 edition of the International Existing Building Code

MEETING DATE: June 23, 2026

DEPARTMENT: Planning

---

### ITEM SUMMARY:

Consideration and action on approval of Ordinance No. 2026-128, approving the 2024 edition of the International Existing Building Code and local amendments thereto.

### INFORMATION:

North Central Texas Council of Governments - Regional Codes Coordinating Committee and its five advisory boards conducted multiple meetings to review the latest editions of the model codes and develop regional amendments. Their review and recommendations are endorsed by NCTCOG's Executive Board. NCTCOG encourages jurisdictions in North Central Texas to adopt the following model construction codes along with their respective regional amendments as expeditiously as their local code adoption process will allow.

NCTCOG issued a memorandum to jurisdictions in North Central Texas to adopt the code updates on May 1, 2025.

### STAFF RECOMMENDATION:

Staff recommends approval.

### SPECIAL CONSIDERATION:

### FINANCIAL CONSIDERATION:

### ATTACHMENTS:



## AGENDA ITEM

1. Ordinance No. 2026-128 - International Existing Building Code - 2024 Edition - with local amendments

**ORDINANCE NO. 2026-128**

**AN ORDINANCE OF THE CITY COUNCIL OF THE CITY OF ROANOKE, TEXAS, AMENDING CHAPTER 3, ARTICLE 3.100 OF THE CODE OF ORDINANCES OF THE CITY OF ROANOKE, TEXAS, ENTITLED “INTERNATIONAL CODES ADOPTED” BY ADDING A NEW SECTION 3.110 ENTITLED “INTERNATIONAL EXISTING BUILDING CODE ADOPTED,” BY ADOPTING THE 2024 EDITION OF THE *INTERNATIONAL EXISTING BUILDING CODE*, AND LOCAL AMENDMENTS TO THE *INTERNATIONAL EXISTING BUILDING CODE*; PROVIDING A SEVERABILITY CLAUSE; PROVIDING A REPEALER CLAUSE; PROVIDING A PENALTY FOR VIOLATIONS; PROVIDING FOR PUBLICATION IN THE OFFICIAL NEWSPAPER; AND PROVIDING FOR AN EFFECTIVE DATE.**

**WHEREAS**, the City Council of the City of Roanoke, Texas, is of the opinion that the 2024 Edition of the *International Existing Building Code*, along with local amendments hereto, should be adopted as the Existing Building Code for the City of Roanoke.

**NOW, THEREFORE, BE IT ORDAINED BY THE CITY COUNCIL OF THE CITY OF ROANOKE, TEXAS, THAT:**

**SECTION 1.  
FINDINGS INCORPORATED**

The findings set forth above are incorporated into the body of this Ordinance as if fully set forth herein.

**SECTION 2.  
AMENDMENT**

Chapter 3, Article 3.100, of the Code of Ordinances of the City of Roanoke, Texas, entitled “International Codes Adopted,” is hereby amended by adding a new Section 3.110 entitled “International Existing Building Code Adopted,” which shall read as follows:

**“Sec. 3.110. International Existing Building Code Adopted.**

- (a) *Adoption.* The *International Existing Building Code*, 2024 edition, is hereby adopted and designated as the Existing Building Code for the City of Roanoke, Texas. A copy of the 2024 Edition of the *International Existing Building Code* is on file in the office of the city secretary.
- (b) *Local Amendments.* The following provisions, attached hereto as **Exhibit A** of this Ordinance, are local amendments to the 2024 Edition of the *International Existing Building Code*. Each provision in this subsection is a substitute for the identically numbered provision contained in the 2024 Edition of the *International Existing*

*Building Code* or is an additional provision added to the 2024 Edition of the *International Existing Building Code*.

**SECTION 3.  
SEVERABILITY CLAUSE**

It is hereby declared to be the intention of the City Council that the phrases, clauses, sentences, paragraphs and sections of this Ordinance are severable, and if any phrase, clause, sentence, paragraph or section of this Ordinance shall be declared unconstitutional by the valid judgment or decree of any court of competent jurisdiction, such unconstitutionality shall not affect any of the remaining phrases, clauses, sentences, paragraphs and sections of this Ordinance, since the same would have been enacted by the City Council without the incorporation of this Ordinance of any such unconstitutional phrase, clause, sentence, paragraph or section.

**SECTION 4.  
REPEALER CLAUSE**

Any provision of any prior ordinance of the City whether codified or uncoded, which are in conflict with any provision of this Ordinance, are hereby repealed to the extent of the conflict, but all other provisions of the ordinances of the City whether codified or uncoded, which are not in conflict with the provisions of this Ordinance, shall remain in full force and effect.

**SECTION 5.  
PENALTY CLAUSE**

Any person, firm, or corporation violating any of the provisions or terms of this Ordinance shall be guilty of a misdemeanor and upon conviction, shall be fined a sum not to exceed \$2,000.00 for each offense, and each and every violation or day such violation shall continue or exist, shall be deemed a separate offense.

**SECTION 6.  
PUBLICATION CLAUSE**

The City Secretary of the City is hereby directed to publish in the official newspaper of the City the caption, penalty clause, and effective date clause of this Ordinance as required by law.

**SECTION 7.  
EFFECTIVE DATE**

This Ordinance shall become effective immediately upon its passage and publication as required by law.

**PASSED, APPROVED AND ADOPTED** by the City Council of the City of Roanoke, Texas, on this June 23, 2026.

**APPROVED:**

\_\_\_\_\_  
Carl E. Gierisch, Jr., Mayor

**ATTEST:**

\_\_\_\_\_  
Lindsay Rawlinson, City Secretary

**APPROVED AS TO FORM:**

\_\_\_\_\_  
Jeff Moore, City Attorney

## Exhibit A

### Local Amendments to the *International Existing Building Code*

#### **Recommended Amendments to the 2024 International Existing Building Code** North Central Texas Council of Governments Region

The following sections, paragraphs, and sentences of the *2024 International Existing Building Code* are hereby amended as follows: Standard type is text from the IEBC. Underlined type is text inserted. ~~Lined through type is deleted text from IEBC.~~ A double asterisk (\*\*) at the beginning of a section identifies an amendment carried over from the 2021 edition of the code and a triple asterisk (\*\*\*) identifies a new or revised amendment with the 2024 code.

**\*\*Section 102.4; change to read as follows:**

**[A] 102.4 Referenced codes and standards.** The codes, when specifically adopted, and standards referenced in this code shall be considered part of the requirements of this code to the prescribed extent of each such reference and as further regulated in Sections 102.4.1 and 102.4.2. {No change to rest of section.}

*(Reason: To not inadvertently adopt other codes (i.e., Wildland Urban Interface Code, etc....) by reference.)*

**\*\*\* Section 102.4.3 add to read as follows:**

**102.4.3 Electrical.** The provisions of the local adopted Electrical Code shall apply to the installation of electrical systems, including alterations, repairs, replacement, equipment, appliances, fixtures, fittings and appurtenances thereto.

*(Reason: Added to IEBC for consistency with IBC. This was dropped when ICC quit publishing the ICC Electrical Code, but the Electrical Code still should be referenced regardless of how it is adopted.)*

**\*\*\*Section 104.2.4.1 Flood hazard areas.** (Jurisdictions may consider the option to amend or delete depending on local enforcement and flood hazard ordinances.)

*(Reason: Added to IEBC for consistency with IBC. Flood hazard ordinances may be administered by other departments within the city.)*

**\*\*\*Section 104.3.1 Determination of substantially improved or substantially damaged existing buildings and structures in flood hazard areas.** (Jurisdictions may consider the option to amend or delete depending on local enforcement and flood hazard ordinances.)

*(Reason: Added to IEBC for consistency with IBC. Flood hazard ordinances may be administered by other departments within the city.)*

**\*\*Section 202; amend definition of Existing Building as follows:**

**Existing Building** - A building, structure, or space with an approved final inspection issued under a code edition which is at least 2 published code editions preceding the currently adopted building code; a building, structure or space that is undergoing a change of occupancy or use. erected prior to the date of adoption of the appropriate code, or one for which a legal building permit has been issued.

*(Reason: To prevent potential abuses in new construction and shell buildings.)*

**\*\*\* Section 302.2 Additional Codes; Amend to read as follows:**

**302.2: Additional Codes**

Alterations, repairs, additions and changes of occupancy to, or relocation of, existing buildings and structures shall comply with the provisions for alterations, repairs, additions and changes of occupancy or relocation, respectively, in this code and the International Energy Conservation Code , International Fire Code, International Fuel Gas Code, International Mechanical Code, International Plumbing Code, International Private Sewage Disposal Code, International Property Maintenance Code, International Residential Code and NFPA 70 and any other Codes or other ordinances adopted by the authority having jurisdiction. Where provisions of the other codes conflict with provisions of this code, the provisions of this code shall take precedence.

*(Reason: Some of the codes listed in this 2024 change may not be adopted by all jurisdictions, additionally there may be specific city ordinances that take precedent over adopted codes.)*

**\*\*\*Section 306.1 Scope; add exceptions to read as follows:**

**Exceptions:**

- 1. Components of projects regulated by and registered with Architectural Barriers Division of Texas Department of Licensing and Regulation shall be deemed to be in compliance with the requirements of this chapter.**

*(Reason: To coordinate with the IBC and State Law for accessibility.)*

**\*\*\* Section 309.2.1 Automatic sprinkler systems; delete this section**

*(Reason: Combustible exterior wall coverings are already addressed in Section 309.2. This proposal is a response to the Grenfell Fire in London. COG amendments in DFW area address high rise buildings aggressively changing the definition to 55 feet, sprinklered and enforcement history of NFPA 285 addressing combustible materials testing.)*

**\*\*Section 401.3 Flood Hazard Areas; delete this section.**

*(Reason: Flood hazard ordinances may be administered by other departments within the city.)*

**\*\*Section 405.2.6 Flood Hazard Areas; delete this section.**

*(Reason: Flood hazard ordinances may be administered by other departments within the city.)*

**\*\*\*Section 502.2 Flood Hazard Areas; delete this section.**

*(Reason: Flood hazard ordinances may be administered by other departments within the city)*

**\*\*Section 503.2 Flood hazard areas; delete this section.**

*(Reason: Flood hazard ordinances may be administered by other departments within the city)*

**\*\*\*Section 503.18 Enhanced classroom acoustics; add after paragraph to read as follows:**

Compliance with the Texas Accessibility Standards is not considered equivalent compliance for the purpose of enforcement of this code section.

*(Reason: TAS does not address this criteria in their evaluation, and it is justifiably required for alterations in existing buildings.)*

**\*\*Section 504.1.2; change to read as follows:**

**504.1.2 Existing fire escapes.** Existing fire escapes shall continue to be accepted as a component in the means of egress in existing buildings only. Existing fire escapes shall be permitted to be repaired or replaced.

*(Reason: To add clarity and help reduce confusion associated with the amendment preventing new fire escapes.)*

**\*\*Section 504.1.3; delete this section:**

~~**504.1.3 New fire escapes.** New fire escapes for existing buildings shall be permitted only where exterior stairways cannot be utilized due to lot lines limiting stairway size or due to the sidewalks, alleys, or roads at grade level. New fire escapes shall not incorporate ladders or access by windows.~~

(Reason: To generally require a higher level of egress protection and consistent with regional practice.)

**\*\*Section 507.3 Flood Hazard Areas; delete this section.**

(Reason: Flood hazard ordinances may be administered by other departments within the city.)

**\*\*Section 701.3 Flood Hazard Areas; delete this section.**

(Reason: Flood hazard ordinances may be administered by other departments within the city.)

**\*\*Section 702.7; add a code reference to read as follows:**

**702.7 Materials and methods.** All new work shall comply with the materials and methods requirements in the *International Building Code*, *International Energy Conservation Code*, *International Mechanical Code*, *National Electrical Code*, and *International Plumbing Code*, as applicable, that specify material standards, detail of installation and connection, joints, penetrations, and continuity of any element, component, or system in the building.

(Reason: To provide a more complete list of potentially adopted codes.)

**\*\*Section 802.5.1; change to read as follows:**

**802.5.1 Minimum requirement.** Every portion of a floor, ~~such as a balcony or a loading deck,~~ open-sided walking surfaces, including *mezzanines, equipment platforms, aisles, stairs, ramps,* and landings that is more than 30 inches (762 mm) above the floor or grade below and is not provided with guards, or those in which the existing guards are judged to be in danger of collapsing, shall be provided with guards.

(Reason: To be consistent with Building Code requirements for guards and unsafe conditions.)

**\*\*Section 803.1 Scope; add sentence to read as follows:**

For the purpose of fire sprinkler protection and fire alarm requirements included in this section, the *work area* shall be extended to include at least the entire tenant space or spaces bounded by walls capable of resisting the passage of smoke containing the subject *work area*, and if the *work area* includes a corridor, hallway, or other exit access, then such corridor, hallway, or other exit access shall be protected in its entirety on that particular floor level.

*(Reason: The intent is to avoid work area protection that would result in partial sprinkler or fire alarm protection. Partial sprinkler protection not delineated by walls would be a clear violation of NFPA 13 and would not allow the sprinkler to perform or function as intended. Also, partial fire alarm coverage is a clear violation of the Fire Code, NFPA 72, and ADA.)*

**\*\*Section 803.3; change section to read as follows:**

**803.3 Standpipes.** Refer to Section 1103.6 of the Fire Code for retroactive standpipe requirements.  
{Delete rest of Section 803.3.}

*(Reason: The Fire Code already requires standpipes in these buildings (greater than 50 ft.) retroactively in Section 1103.6. This new section would negate/lessen those retroactive provisions already contained in the Fire Code.)*

**\*\*Section 804.2 General; delete Exception #1 as follows:**

**Exceptions:** 1. ~~Where the work area and the means of egress serving it complies with NFPA101.~~  
2. [Remain unchanged]

*(Reason: NFPA 101 is not a commonly adopted code in the region and enforcement would be problematic, especially due to contradictions with the requirements of the IBC.)*

**\*\*\*Section 804.5.1.2.; change to read as follows:**

**804.5.1.2 Fire Escapes required.** For other than Group I-2, where more than one exit is required, an existing ~~or newly constructed~~ fire escape complying with section 805.3.1.2.1 shall be accepted as providing one of the required means of egress.

*(Reason: Higher level of safety by not allowing new fire escapes and consistent with regional practice.)*

**\*\*\*Section 804.5.1.2.1; change to read as follows:**

**804.5.1.2.1 Fire Escape access and details - ...**

1. [Remain unchanged]
2. Access to a ~~new~~ fire escape shall be through a door...[remainder unchanged]
3. ~~Newly constructed fire escapes shall be permitted only where exterior stairways cannot be utilized because of lot lines limiting the stairway size or because of the sidewalks, alleys, or roads at grade level.~~
4. [Remain unchanged]
5. In all buildings of Group E occupancy up to and including the 12<sup>th</sup> grade, buildings of Group I occupancy, ~~rooming~~ boarding houses, and childcare centers, ladders of any type are prohibited on fire escapes used as a

required means of egress.

*(Reason: Higher level of safety by not allowing new fire escapes. Consistency with language and defined term in IBC.)*

**\*\*\*Section 804.7.2 Transoms; amend to read as follows:**

**804.7.2 Transoms.** In all buildings of Group B, E, I-1, I-2, R-1 and R-2 occupancies, ...[Remainder unchanged]

*(Reason: Transom windows were historically a common practice in school buildings and each jurisdiction should evaluate the impact on their stakeholders and their community with regards to this section.)*

**\*\*Section 904.1 Automatic sprinkler systems; add sentence to read as follows:**

For the purpose of fire sprinkler protection and fire alarm requirements included in this section, the work area shall be extended to include at least the entire tenant space or spaces bounded by walls containing the subject work area, and if the work area includes a corridor, hallway, or other exit access, then such corridor, hallway, or other exit access shall be protected in its entirety on that particular floor level.

*(Reason: The intent is to avoid work area protection that would result in partial sprinkler or fire alarm protection. Partial sprinkler protection not delineated by walls would be a clear violation of NFPA 13 and the Fire Code and would not allow the sprinkler system to perform or function as intended. Also, partial fire alarm coverage is a clear violation of the Fire Code, NFPA 72, and ADA.)*

**\*\*Section 904.1.1; change to read as follows:**

**904.1.1 High-rise buildings.** An automatic sprinkler system shall be provided in work areas of ~~where the~~ high-rise buildings. ~~has a sufficient municipal water supply for the design and installation of an automatic sprinkler system at the site.~~

*(Reason: Level 3 alterations are affecting more than 50% of the existing high-rise building, and as such, sprinkler protection is more than justifiable, even when fire pumps, etc., are necessary. It is noted that the work area method is one of three different methods available to the designer/owner in the IEBC.)*

**\*\*\*Section 1011.2.1: change to read as follows:**

**1011.2.1 Automatic Fire sprinkler system.** The installation of an automatic sprinkler system shall be required where there is a change of occupancy classification and Chapter 9 of the current International Building Code requires an automatic sprinkler

system based on the new occupancy or where there is a change of occupancy within the space where there is a different fire protection system threshold requirement in Chapter 9 of the current International Building Code than exists in the current building or space. The installation of the automatic sprinkler system shall be required within the area of the change of occupancy and areas of the building not separated horizontally and vertically from the change of occupancy by a ~~nonrated permanent partition and horizontal assemblies, fire partition, smoke partition, smoke barrier, fire barrier or fire wall.~~

*(Reason: 2024 IEBC rearranged text. Section was re-written previous items in #1-6 are now in the main charging language of 1011.2.1. Maintains legacy language requiring at least fire barrier separation between a newly sprinklered more hazardous 'change of occupancy' from non-sprinklered existing occupancies, as is required for fire area separation by the IBC.*

**\*\*Section 1103.3 Flood Hazard Areas; delete this section.**

*(Reason: Flood hazard ordinances may be administered by other departments within the city.)*

**\*\*Section 1201.4 Flood Hazard Areas; delete this section.**

*(Reason: Flood hazard ordinances may be administered by other departments within the city.)*

**\*\*Section 1303.1.2; change to read as follows:**

**1301.3.2 Compliance with other codes.** Buildings that are evaluated in accordance with this section shall comply with the International Fire Code. ~~and International Property Maintenance Code.~~

*(Reason: NCTCOG does not currently recommend, nor review the IPMC for recommended amendments at this time.)*

**\*\*\*Section 1303.1.3 Compliance with Flood Hazard Provisions; delete this section.**

*(Reason: Flood hazard ordinances may be administered by other departments within the city.)*

**\*\*Section 1402.6 Flood Hazard Areas; delete this section.**

*(Reason: Flood hazard ordinances may be administered by other departments within the city.)*

**\*\*\*[F] Section 1502.1 Site safety plan; change to read**

[Existing text remains]

The plan shall be submitted and approved by the Fire Department before a building permit is issued, [Remainder of Existing text remains]

*(Reason: Safety plan components require compliance with IFC.)*

**\*\*\*[F] Section 1502.3.1 Violations; change to read**

Failure to properly conduct, document and maintain documentation required by this section shall constitute an unlawful act in accordance with Section 113.1 and shall result in the issuance of a notice of violation, by the Fire code official, to the site safety director. ~~in accordance with Section 113.2.~~ Upon the third offense, the Fire code official, based on their findings, shall request a stop work order enforcement be implemented to the code official in accordance with Section 114, and work shall not resume until satisfactory assurances of future compliance have been presented to and approved by the code official.

*(Reason: Safety plan components require compliance with IFC.)*

**\*\*\*Section 1512.1 When Required; delete Section 1512.1 through 1512.5 and change Section 1512.1 to read as follows:**

**1512.1 When required.** An approved water supply for fire protection, either temporary or permanent, shall be made available as soon as combustible material arrives on the site or as determined by the code official. The water supply design and the timing of the water supply installation relative to building construction shall comply with the adopted Fire Code.

*(Reason: Maintains legacy language for the water supply and ensures adequate water supply as required by the Fire Code for construction that is already well-established. The changes previously published by IEBC drastically reduce the required water supply of the Fire Code without adequate or reasonable justification.)*

**END**



## AGENDA ITEM

TO: Mayor and City Council

SUBJECT: 2024 edition of the International Fuel Gas Code

MEETING DATE: June 23, 2026

DEPARTMENT: Planning

---

### ITEM SUMMARY:

Consideration and action on approval of Ordinance No. 2026-129, approving the 2024 edition of the International Fuel Gas Code and local amendments thereto.

### INFORMATION:

North Central Texas Council of Governments - Regional Codes Coordinating Committee and its five advisory boards conducted multiple meetings to review the latest editions of the model codes and develop regional amendments. Their review and recommendations are endorsed by NCTCOG's Executive Board. NCTCOG encourages jurisdictions in North Central Texas to adopt the following model construction codes along with their respective regional amendments as expeditiously as their local code adoption process will allow.

NCTCOG issued a memorandum to jurisdictions in North Central Texas to adopt the code updates on May 1, 2025.

### STAFF RECOMMENDATION:

Staff recommends approval.

### SPECIAL CONSIDERATION:

### FINANCIAL CONSIDERATION:

### ATTACHMENTS:



## AGENDA ITEM

1. Ordinance No. 2026-129 - International Fuel Gas Code - 2024 Edition - with local amendments

**ORDINANCE NO. 2026-129**

**AN ORDINANCE OF THE CITY COUNCIL OF THE CITY OF ROANOKE, TEXAS, AMENDING CHAPTER 3, ARTICLE 3.100 OF THE CODE OF ORDINANCES OF THE CITY OF ROANOKE, TEXAS, ENTITLED “INTERNATIONAL CODES ADOPTED” BY REPEALING IN ITS ENTIRETY SECTION 3.109 ENTITLED “INTERNATIONAL FUEL GAS CODE ADOPTED,” AND REPLACING IT WITH A NEW SECTION 3.109 ENTITLED “INTERNATIONAL FUEL GAS CODE ADOPTED,” BY ADOPTING THE 2024 EDITION OF THE *INTERNATIONAL FUEL GAS CODE*, AND LOCAL AMENDMENTS TO THE *INTERNATIONAL FUEL GAS CODE*; PROVIDING A SEVERABILITY CLAUSE; PROVIDING A REPEALER CLAUSE; PROVIDING A PENALTY FOR VIOLATIONS; PROVIDING FOR PUBLICATION IN THE OFFICIAL NEWSPAPER; AND PROVIDING FOR AN EFFECTIVE DATE.**

**WHEREAS**, the City Council of the City of Roanoke, Texas, is of the opinion that the 2024 Edition of the *International Fuel Gas Code*, along with local amendments hereto, should be adopted as the Fuel Gas Code for the City of Roanoke.

**NOW, THEREFORE, BE IT ORDAINED BY THE CITY COUNCIL OF THE CITY OF ROANOKE, TEXAS, THAT:**

**SECTION 1.  
FINDINGS INCORPORATED**

The findings set forth above are incorporated into the body of this Ordinance as if fully set forth herein.

**SECTION 2.  
AMENDMENT**

Chapter 3, Article 3.100, of the Code of Ordinances of the City of Roanoke, Texas, entitled “International Codes Adopted,” is amended by repealing in its entirety Section 3.109 entitled “International Fuel Gas Code Adopted” and replacing it with a new Section 3.109 entitled “International Fuel Gas Code Adopted,” which shall read as follows:

**“Sec. 3.109. International Fuel Gas Code Adopted.**

- (a) *Adoption.* The *International Fuel Gas Code*, 2024 edition, is hereby adopted and designated as the Fuel Gas Code for the City of Roanoke, Texas. A copy of the 2024 Edition of the *International Fuel Gas Code* is on file in the office of the city secretary.
- (b) *Local Amendments.* The following provisions, attached hereto as **Exhibit A** of this Ordinance, are local amendments to the 2024 Edition of the *International Fuel Gas*

*Code.* Each provision in this subsection is a substitute for the identically numbered provision contained in the 2024 Edition of the *International Fuel Gas Code* or is an additional provision added to the 2024 Edition of the *International Fuel Gas Code*.

**SECTION 3.  
SEVERABILITY CLAUSE**

It is hereby declared to be the intention of the City Council that the phrases, clauses, sentences, paragraphs and sections of this Ordinance are severable, and if any phrase, clause, sentence, paragraph or section of this Ordinance shall be declared unconstitutional by the valid judgment or decree of any court of competent jurisdiction, such unconstitutionality shall not affect any of the remaining phrases, clauses, sentences, paragraphs and sections of this Ordinance, since the same would have been enacted by the City Council without the incorporation of this Ordinance of any such unconstitutional phrase, clause, sentence, paragraph or section.

**SECTION 4.  
REPEALER CLAUSE**

Any provision of any prior ordinance of the City whether codified or uncoded, which are in conflict with any provision of this Ordinance, are hereby repealed to the extent of the conflict, but all other provisions of the ordinances of the City whether codified or uncoded, which are not in conflict with the provisions of this Ordinance, shall remain in full force and effect.

**SECTION 5.  
PENALTY CLAUSE**

Any person, firm, or corporation violating any of the provisions or terms of this Ordinance shall be guilty of a misdemeanor and upon conviction, shall be fined a sum not to exceed \$2,000.00 for each offense, and each and every violation or day such violation shall continue or exist, shall be deemed a separate offense.

**SECTION 6.  
PUBLICATION CLAUSE**

The City Secretary of the City is hereby directed to publish in the official newspaper of the City the caption, penalty clause, and effective date clause of this Ordinance as required by law.

**SECTION 7.  
EFFECTIVE DATE**

This Ordinance shall become effective immediately upon its passage and publication as required by law.

**PASSED, APPROVED AND ADOPTED** by the City Council of the City of Roanoke, Texas, on this June 23, 2026.

**APPROVED:**

\_\_\_\_\_  
Carl E. Gierisch, Jr., Mayor

**ATTEST:**

\_\_\_\_\_  
Lindsay Rawlinson, City Secretary

**APPROVED AS TO FORM:**

\_\_\_\_\_  
Jeff Moore, City Attorney

## Exhibit A

### Local Amendments to the *International Fuel Gas Code*

#### **Recommended Amendments to the 2024 International Fuel Gas Code** North Central Texas Council of Governments Region

The following sections, paragraphs, and sentences of the *2024 International Fuel Gas Code* are hereby amended as follows: Standard type is text from the IFGC. Underlined type is text inserted. ~~Lined through type is deleted text from IFGC.~~ A double asterisk at the beginning of a section identifies an amendment carried over from the 2021 edition of the code and a triple asterisk identifies a new or revised amendment with the 2024 code.

**\*\*Section 102.2; add an exception to read as follows:**

**Exception:** Existing dwelling units shall comply with Section 621.2.

*(Reason: Previous code provisions made unvented heater provisions retroactive except as provided for in local amendment. This amendment and amendment to IFGC 621.2 better clarify what the code already states: existing systems may stay unless considered unsafe.)*

**\*\*Section 102.8; change to read as follows:**

**102.8 Referenced codes and standards.** The codes and standards referenced in this code shall be those that are listed in Chapter 8 and such codes, when specifically adopted, and standards shall be considered part of the requirements of this code to the prescribed extent of each such reference and as further regulated in Sections 102.8.1 and 102.8.2. Whenever amendments have been adopted to the referenced codes and standards, each reference to said code and standard shall be considered to reference the amendments as well. Any reference to NFPA 70 or the *National Electrical Code* shall mean the National Electrical Code as adopted.

**Exception:** Where enforcement of a code provision would violate the conditions of the listing of the *equipment* or *appliance*, the conditions of the listing and the manufacturer's installation instructions shall apply.

*(Reason: Legal wording to recognize locally adopted codes and amendments adopted with referenced codes.)*

**\*\*\*Section 306.3; change to read as follows:**

**306.3 Appliances in attics.** Attics containing *appliances* shall be provided with an opening and unobstructed passageway large enough to allow removal of the largest *appliance*. The passageway shall be not less than 30 inches (762 mm) high and 22 inches

(599 mm) wide and to more than 20 feet (6096 mm) in length measured along the centerline of the passageway from the opening to the *appliance*. The passageway shall have continuous solid flooring not less than 24 inches (610 mm) wide. A level service space not less than 30 inches (762 mm) deep and 30 inches (762 mm) wide shall be present at the front or service side of the *appliance*. The clear access opening dimensions shall be not less than 20 inches by 30 inches (508 mm by 762 mm), and large enough to allow removal of the largest appliance. As a minimum access to the attic space shall be provided by one of the following:

1. A permanent Stair.
2. A pull-down stair with a minimum 300 lb (136 kg) capacity.
3. An access door from an upper floor level.

**Exceptions:**

1. The passageway and level service space are not required where the *appliance* is capable of being serviced and removed through the required opening with the approval of the code official.
2. Where the passageway is unobstructed and not less than 6 feet (1829 mm) high and 22 inches (559 mm) wide for its entire length, the passageway shall be not greater than 50 feet (15,250 mm) in length.

*(Reason: To provide adequate access to appliances for service or replacement with safe access.)*

**\*\*Section 306.5.1; change to read as follows:**

**[M] 306.5.1 Sloped roofs.** Where appliances, *equipment*, fans or other components that require service are installed on a roof having a slope of 3 units vertical in 12 units horizontal (25-percent slope) or greater and having an edge more than 30 inches (762 mm) above grade at such edge, a catwalk at least 16 inches in width with substantial cleats spaced not more than 16 inches apart shall be provided from the roof access to a level platform at the appliance. The level platform shall be provided on each side of the appliance to which access is required for service, repair or maintenance. The platform shall be not less than 30 inches (762 mm) in any dimension and shall be provided with guards. The guards shall extend not less than 42 inches (1067 mm) above the platform, shall be constructed so as to prevent the passage of a 21-inch-diameter (533 mm) sphere and shall comply with the loading requirements for guards specified in the *International Building Code*. *(remainder of text unchanged)*.

*(Reason: To assure safe access to roof appliances. Consistent with IMC amendments.)*

**\*\*Section 401.5; add a second paragraph to read as follows:**

Both ends of each section of medium pressure gas piping shall identify its operating gas pressure with an approved tag. The tags are to be composed of aluminum or stainless steel and the following wording shall be stamped into the tag:

"WARNING  
1/2 to 5 psi gas pressure  
Do Not Remove"

*(Reason: To protect owners and plumbers.)*

**\*\*Section 404.12; change to read as follows:**

**404.12 Minimum burial depth.** Underground piping systems shall be installed a minimum depth of 12 18 inches (305 458 mm) top of pipe below grade, except as provided for in Section 404.12.1.

*(Reason: To provide increased protection to piping systems and address reference number change.)*

**\*\*Section 406.4; change to read as follows:**

**406.4 Test pressure measurement.** Test pressure shall be measured with a monometer or with a pressure-measuring device designed and calibrated to read, record, or indicate a pressure loss caused by leakage during the pressure test period. The source of pressure shall be isolated before the pressure tests are made. Mechanical gauges used to measure test pressures shall have a range such that the highest end of the scale is not greater than five times the test pressure. Spring type gauges do not meet the requirement of a calibrated gauge.

*(Reason: To require the use of more accurate diaphragm gauges. Spring gauges do not provide accurate measurement below approximately 17 psig.)*

**\*\*Section 406.4.1; change to read as follows:**

**406.4.1 Test pressure.** The test pressure to be used shall be no less than 1 1/2 times the proposed maximum working pressure, but no less than 3 3 psig (20 kPa gauge), or at the discretion of the Code Official, the piping and valves may be tested at a pressure of at least six (6) inches (152 mm) of mercury, measured with a manometer or slope gauge, irrespective of design pressure. Where the test pressure exceeds 125 psig (862 kPa gauge), the test pressure shall not exceed a value that produces a hoop stress in the piping greater than 50 percent of the specified minimum yield strength of the pipe. For tests requiring a pressure of 3 psig, diaphragm gauges shall utilize a dial with a minimum diameter of three and one half inches (3 1/2"), a set hand, 1/10 pound incrementation and pressure range not to exceed 15 psi for tests requiring a pressure of 3 psig. For tests requiring a pressure of 10 psig, diaphragm gauges shall utilize a dial with a minimum diameter of three and one-half inches (3 1/2"), a set hand, a minimum of 2/10 pound incrementation and a pressure range not to exceed 50 psi. For welded piping, and for piping carrying gas at pressures in excess of fourteen (14) inches water column pressure (3.48 kPa) (1/2 psi) and less than 200 inches of water column pressure (52.2 kPa) (7.5

psi), the test pressure shall not be less than ten (10) pounds per square inch (69.6 kPa). For piping carrying gas at a pressure that exceeds 200 inches of water column (52.2 kPa) (7.5 psi), the test pressure shall be not less than one and one-half times the proposed maximum working pressure.

Diaphragm gauges used for testing must display a current calibration and be in good working condition. The appropriate test must be applied to the diaphragm gauge used for testing.

*(Reason: To provide for lesser pressures to coordinate with the use of more accurate diaphragm gauges.)*

**\*\*Section 409.1; add Section 409.1.4 to read as follows:**

**409.1.4 Valves in CSST installations.** Shutoff valves installed with corrugated stainless steel (CSST) piping systems shall be supported with an *approved* termination fitting, or equivalent support, suitable for the size of the valves, of adequate strength and quality, and located at intervals so as to prevent or damp out excessive vibration but in no case greater than 12-inches from the center of the valve. Supports shall be installed so as not to interfere with the free expansion and contraction of the system's piping, fittings, and valves between anchors. All valves and supports shall be designed and installed so they will not be disengaged by movement of the supporting piping.

*(Reason: To provide proper security to CSST valves. These standards were established in this region in 1999 when CSST was an emerging technology.)*

**\*\*Section 410.1; add a second paragraph and exception to read as follows:**

Access to regulators shall comply with the requirements for access to appliances as specified in Section 306.

**Exception:** A passageway or level service space is not required when the regulator is capable of being serviced and removed through the required attic opening.

*(Reason: To require adequate access to regulators.)*

**\*\*Section 621.2; add exception as follows:**

**621.2 Prohibited use.** One or more unvented room heaters shall not be used as the sole source of comfort heating in a dwelling unit.

**Exception:** Existing *approved* unvented heaters may continue to be used in dwelling units, in accordance with the code provisions in effect when installed, when *approved* by the Code Official unless an unsafe condition is determined to exist as described in Section 108.7.

*(Reason: Gives code official discretion.)*



**END**



## AGENDA ITEM

TO: Mayor and City Council

SUBJECT: 2024 edition of the International Mechanical Code

MEETING DATE: June 23, 2026

DEPARTMENT: Planning

---

### ITEM SUMMARY:

Consideration and action on approval of Ordinance No. 2026-130, approving the 2024 edition of the International Mechanical Code and local amendments thereto.

### INFORMATION:

North Central Texas Council of Governments - Regional Codes Coordinating Committee and its five advisory boards conducted multiple meetings to review the latest editions of the model codes and develop regional amendments. Their review and recommendations are endorsed by NCTCOG's Executive Board. NCTCOG encourages jurisdictions in North Central Texas to adopt the following model construction codes along with their respective regional amendments as expeditiously as their local code adoption process will allow.

NCTCOG issued a memorandum to jurisdictions in North Central Texas to adopt the code updates on May 1, 2025.

### STAFF RECOMMENDATION:

Staff recommends approval.

### SPECIAL CONSIDERATION:

### FINANCIAL CONSIDERATION:

### ATTACHMENTS:



## AGENDA ITEM

1. Ordinance No. 2026-130 - International Mechanical Code - 2024 Edition - with local amendments

**ORDINANCE NO. 2026-130**

**AN ORDINANCE OF THE CITY COUNCIL OF THE CITY OF ROANOKE, TEXAS, AMENDING CHAPTER 3, ARTICLE 3.100 OF THE CODE OF ORDINANCES OF THE CITY OF ROANOKE, TEXAS, ENTITLED “INTERNATIONAL CODES ADOPTED” BY REPEALING IN ITS ENTIRETY SECTION 3.105 ENTITLED “INTERNATIONAL MECHANICAL CODE ADOPTED,” AND REPLACING IT WITH A NEW SECTION 3.105 ENTITLED “INTERNATIONAL MECHANICAL CODE ADOPTED,” BY ADOPTING THE 2024 EDITION OF THE *INTERNATIONAL MECHANICAL CODE*, AND LOCAL AMENDMENTS TO THE *INTERNATIONAL MECHANICAL CODE*; PROVIDING A SEVERABILITY CLAUSE; PROVIDING A REPEALER CLAUSE; PROVIDING A PENALTY FOR VIOLATIONS; PROVIDING FOR PUBLICATION IN THE OFFICIAL NEWSPAPER; AND PROVIDING FOR AN EFFECTIVE DATE.**

**WHEREAS**, the City Council of the City of Roanoke, Texas, is of the opinion that the 2024 Edition of the *International Mechanical Code*, along with local amendments hereto, should be adopted as the Mechanical Code for the City of Roanoke.

**NOW, THEREFORE, BE IT ORDAINED BY THE CITY COUNCIL OF THE CITY OF ROANOKE, TEXAS:**

**SECTION 1.  
FINDINGS INCORPORATED**

The findings set forth above are incorporated into the body of this Ordinance as if fully set forth herein.

**SECTION 2.  
AMENDMENT**

Chapter 3, Article 3.100, of the Code of Ordinances of the City of Roanoke, Texas, entitled “International Codes Adopted,” is hereby amended by repealing in its entirety Section 3.105 entitled “International Mechanical Code Adopted” and replacing it with a new Section 3.105 entitled “International Mechanical Code Adopted,” which shall read as follows:

**“Sec. 3.105. International Mechanical Code Adopted.**

- (a) *Adoption.* The *International Mechanical Code*, 2024 edition, is hereby adopted and designated as the Mechanical Code for the City of Roanoke, Texas. A copy of the 2024 Edition of the *International Mechanical Code* is on file in the office of the city secretary.

- (b) *Local Amendments.* The following provisions, attached hereto as **Exhibit A** of this Ordinance, are local amendments to the 2024 Edition of the *International Mechanical Code*. Each provision in this subsection is a substitute for the identically numbered provision contained in the 2024 Edition of the *International Mechanical Code* or is an additional provision added to the 2024 Edition of the *International Mechanical Code*.

### **SECTION 3. SEVERABILITY CLAUSE**

It is hereby declared to be the intention of the City Council that the phrases, clauses, sentences, paragraphs and sections of this Ordinance are severable, and if any phrase, clause, sentence, paragraph or section of this Ordinance shall be declared unconstitutional by the valid judgment or decree of any court of competent jurisdiction, such unconstitutionality shall not affect any of the remaining phrases, clauses, sentences, paragraphs and sections of this Ordinance, since the same would have been enacted by the City Council without the incorporation of this Ordinance of any such unconstitutional phrase, clause, sentence, paragraph or section.

### **SECTION 4. REPEALER CLAUSE**

Any provision of any prior ordinance of the City whether codified or uncoded, which are in conflict with any provision of this Ordinance, are hereby repealed to the extent of the conflict, but all other provisions of the ordinances of the City whether codified or uncoded, which are not in conflict with the provisions of this Ordinance, shall remain in full force and effect.

### **SECTION 5. PENALTY CLAUSE**

Any person, firm, or corporation violating any of the provisions or terms of this Ordinance shall be guilty of a misdemeanor and upon conviction, shall be fined a sum not to exceed \$2,000.00 for each offense, and each and every violation or day such violation shall continue or exist, shall be deemed a separate offense.

### **SECTION 6. PUBLICATION CLAUSE**

The City Secretary of the City is hereby directed to publish in the official newspaper of the City the caption, penalty clause, and effective date clause of this Ordinance as required by law.

**SECTION 7.  
EFFECTIVE DATE**

This Ordinance shall become effective immediately upon its passage and publication as required by law.

**PASSED, APPROVED AND ADOPTED** by the City Council of the City of Roanoke, Texas, on this June 23, 2026.

**APPROVED:**

\_\_\_\_\_  
Carl E. Gierisch, Jr., Mayor

**ATTEST:**

\_\_\_\_\_  
Lindsay Rawlinson, City Secretary

**APPROVED AS TO FORM:**

\_\_\_\_\_  
Jeff Moore, City Attorney

## **Exhibit A**

### Local Amendments to the *International Mechanical Code*

#### **Recommended Amendments to the 2024 International Mechanical Code** North Central Texas Council of Governments Region

The following sections, paragraphs, and sentences of the *2024 International Mechanical Code* (IMC) are hereby amended as follows: Standard type is text from the IMC. Underlined type is text inserted. ~~Lined through type is deleted text from the IMC.~~ A double asterisk at the beginning of a section identifies an amendment carried over from the 2021 edition of the code and a triple asterisk identifies a new or revised amendment of the 2024 edition of the code.

Note: Historically the North Central Texas Council of Governments (NCTCOG) has limited Chapter 1 amendments in order to allow each city to insert their local policies and procedures. We now have suggested certain items to be brought to the attention of cities considering adoption of the code that may be of concern to several jurisdictions. **It is still intended to be discretionary to each city to determine which Chapter 1 amendments to include.**

**\*\*Section 102.8; change to read as follows:**

**102.8 Referenced Codes and Standards.** The codes and standards referenced herein shall be those that are listed in Chapter 15 and such codes and standards, when specifically adopted, shall be considered part of the requirements of this code to the prescribed extent of each such reference and as further regulated in Sections 102.8.1 and 102.8.2.

Whenever amendments have been adopted to the referenced codes and standards, each reference to said code and standard shall be considered to reference the adopted amendments. Any reference to NFPA 70 shall mean the National Electrical Code as adopted.

Exception: Where enforcement of a code provision would violate the conditions of the listing of the *equipment* or *appliance*, the conditions of the listing and the manufacturer's installation instruction shall apply.

*(Reason: Legal wording to recognize locally adopted codes and amendments adopted with referenced codes.)*

**\*\*\*Section 202; add definition of Effective Dispersal Volume Charge as follows:**

**Effective Dispersal Volume Charge (EDVC).** The maximum refrigerant charge permitted for an effective dispersal volume.

*(Reason: These are additional terms used in ASHRAE 15 to determine refrigerant concentrations and methods to mitigate refrigerant concentrations from exceeding the refrigerant concentration limit.)*

**\*\*\*Section 202; add definition of Refrigerant Detection System as follows:**

**Refrigerant Detection System** - The product safety standard addresses both refrigerant detection systems and leak detection systems. In the product safety standard, a leak detection system is defined as “a sensing system which responds to refrigerant leaking from a refrigerating system.” A leak detection system may include gas sensing, ultrasonic, or other such methods that meet the standards UL 60335-2-40/CSA C22.2 No. 60335-2-40 or UL 60335-2-89/CSA C22.2 No. 60335-2-89. [ASHRAE 15-2022: 3.1]

*(Reason: These are additional terms used in ASHRAE 15 to determine refrigerant concentrations and methods to mitigate refrigerant concentrations from exceeding the refrigerant concentration limit.)*

**\*\*\*Section 202; add definition of Refrigerant Detector as follows:**

**Refrigerant Detector** - “Refrigerant sensor” is another term for refrigerant detector. A refrigerant sensor is a sensing element combined with electronic circuitry that provides a digital output or an analog signal output that corresponds to the sensed refrigerant gas concentration. [ASHRAE 15-2022: 3.1]

*(Reason: These are additional terms used in ASHRAE 15 to determine refrigerant concentrations and methods to mitigate refrigerant concentrations from exceeding the refrigerant concentration limit.)*

**\*\*Section 306.3; change to read as follows:**

**306.3 Appliances in attics.** Attics containing *appliances* shall be provided with an opening and unobstructed passageway large enough to allow removal of the largest *appliance*. The passageway shall be not less than 30 inches (762 mm) high and 22 inches (599 mm) wide and to more than 20 feet (6096 mm) in length measured along the centerline of the passageway from the opening to the *appliance*. The passageway shall have continuous solid flooring not less than 24 inches (610 mm) wide. A level service space not less than 30 inches (762 mm) deep and 30 inches (762 mm) wide shall be present at the front or service side of the *appliance*. The clear access opening dimensions shall be not less than 20 inches by 30 inches (508 mm by 762 mm), and large enough to allow removal of the largest appliance. As a minimum access to the attic space shall be provided by one of the following:

1. A permanent Stair.
2. A pull-down stair with a minimum 300 lb (136 kg) capacity.
3. An access door from an upper floor level.

**Exceptions:**

1. The passageway and level service space are not required where the *appliance* is capable of being serviced and removed through the required opening with the approval of the code official.
2. Where the passageway is unobstructed and not less than 6 feet (1829 mm) high and 22 inches (559 mm) wide for its entire length, the passageway shall be not greater than 50 feet (15,250 mm) in length.

*(Reason: To provide adequate access to appliances for service or replacement with safe access.)*

**\*\*Section 306.5.1; change to read as follows:**

**306.5.1 Sloped Roofs.** Where appliances, *equipment*, fans or other components that require service are installed on a roof having a slope of 3 units vertical in 12 units horizontal (25-percent slope) or greater and having an edge more than 30 inches (762 mm) above grade at such edge, a catwalk at least 16 inches in width with substantial cleats spaced not more than 16 inches apart shall be provided from the roof access to a level platform at the appliance. The level platform shall be provided on each side of the *appliance* or *equipment* to which access is required for service, repair or maintenance. The platform shall be not less than 30 inches (762 mm) in any dimension and shall be provided with guards. The guards shall extend not less than 42 inches (1067 mm) above the platform, shall be constructed so as to prevent the passage of a 21-inch-diameter (533 mm) sphere and shall comply with the loading requirements for guards specified in the *International Building Code*...*{remainder of text unchanged}*.

*(Reason: To assure safe access to roof appliances. Consistent with IFGC amendments.)*

**\*\*Section 501.3; add an exception to read as follows:**

**501.3 Exhaust Discharge.** The air removed by every mechanical exhaust system shall be discharged outdoors at a point where it will not cause a public nuisance and not less than the distances specified in Section 501.3.1. The air shall be discharged to a location from which it cannot again be readily drawn in by a ventilating system. Air shall not be exhausted into an attic, crawl space, or be directed onto walkways.

**Exceptions:**

1. Whole-house ventilation-type attic fans shall be permitted to discharge into the attic space of dwelling units having private attics.
2. Commercial cooking recirculating systems.
3. Where installed in accordance with the manufacturer's instructions and where mechanical or natural ventilation is otherwise provided in accordance with

Chapter 4, listed and labeled domestic ductless range hoods shall not be required to discharge to the outdoors.

4. Toilet room exhaust ducts may terminate in a warehouse or shop area when infiltration of outside air is present.

*(Reason: Provide a reasonable alternative in areas where a large volume of outside air is present.)*

**\*\*Section 1104.2 Machinery Room ; add an exception to read as follows:**

**Exception**

3. Machinery Rooms are not required when in compliance with ASHRAE 15 Section 7.4.

*(Reason: Using the ASHRAE 15 machinery room requirements, the single and multiple circuit refrigeration systems use release mitigation strategies to safely isolate a section to prevent a full single circuit discharge of a refrigerant with automatic safety shutoff valves. An example of this is in VRF systems where Branch selector boxes/Heat recovery units)*

**\*\*\* Section 1104.3.1.1 Group A2L High-Probability Systems. Add this section to read:**

**1104.3.1.1 Group A2L High-Probability Systems.** High-probability systems using Group A2L refrigerants shall comply with ASHRAE 15 section 7.6.

*(Reason: The 2024 IMC permits the use of Group A2L High-probability systems; however, it does not cover the safe limits and refrigerant detection and mitigation requirements for systems outside of a machinery room.)*

**\*\*\*Section 1109.2.5 Refrigerant pipe shafts. Change to read:**

[Existing text to remain]

**Exceptions:**

1. [Existing text to remain]
2. Piping in a direct refrigeration system ~~using Group A4~~ where the refrigerant quantity does not exceed the limits of Table 1103.1 for the smallest occupied space through which the piping passes.
3. [Existing text to remain]

*(Reason: This will make the IMC consistent with Section 9.12.1.5 of ASHRAE 15-2022. Note that IMC Section 1109.2.2 still requires piping protection, either within building elements or protective enclosures. This is in line with both ASHRAE 15-2019 section 8.10.2 and ASHRAE 15-2022 section 9.12.1.5.1 where the refrigerant safety group is*

*not mentioned, only the refrigerant concentration limit (RCL). The RCL for groups other than A1 is either 25% of the LFL or lower to account for flammability, toxicity, and oxygen deprivation. )*

***END***



## AGENDA ITEM

TO: Mayor and City Council

SUBJECT: 2024 edition of the International Plumbing Code

MEETING DATE: June 23, 2026

DEPARTMENT: Planning

---

### ITEM SUMMARY:

Consideration and action on approval of Ordinance No. 2026-131, approving the 2024 edition of the International Plumbing Code and local amendments thereto.

### INFORMATION:

North Central Texas Council of Governments - Regional Codes Coordinating Committee and its five advisory boards conducted multiple meetings to review the latest editions of the model codes and develop regional amendments. Their review and recommendations are endorsed by NCTCOG's Executive Board. NCTCOG encourages jurisdictions in North Central Texas to adopt the following model construction codes along with their respective regional amendments as expeditiously as their local code adoption process will allow.

NCTCOG issued a memorandum to jurisdictions in North Central Texas to adopt the code updates on May 1, 2025.

### STAFF RECOMMENDATION:

Staff recommends approval.

### SPECIAL CONSIDERATION:

### FINANCIAL CONSIDERATION:

### ATTACHMENTS:



## AGENDA ITEM

1. Ordinance No. 2026-131 - International Plumbing Code - 2024 Edition - with local amendments

ORDINANCE NO. 2026-131

AN ORDINANCE OF THE CITY COUNCIL OF THE CITY OF ROANOKE, TEXAS, AMENDING CHAPTER 3, ARTICLE 3.100 OF THE CODE OF ORDINANCES OF THE CITY OF ROANOKE, TEXAS, ENTITLED "INTERNATIONAL CODES ADOPTED" BY REPEALING IN ITS ENTIRETY SECTION 3.104 ENTITLED "INTERNATIONAL PLUMBING CODE ADOPTED," AND REPLACING IT WITH A NEW SECTION 3.104 ENTITLED "INTERNATIONAL PLUMBING CODE ADOPTED," BY ADOPTING THE 2024 EDITION OF THE *INTERNATIONAL PLUMBING CODE*, AND LOCAL AMENDMENTS TO THE *INTERNATIONAL PLUMBING CODE*; PROVIDING A SEVERABILITY CLAUSE; PROVIDING A REPEALER CLAUSE; PROVIDING A PENALTY FOR VIOLATIONS; PROVIDING FOR PUBLICATION IN THE OFFICIAL NEWSPAPER; AND PROVIDING FOR AN EFFECTIVE DATE.

**WHEREAS**, the City Council of the City of Roanoke, Texas, is of the opinion that the 2024 Edition of the *International Plumbing Code*, along with local amendments hereto, should be adopted as the Plumbing Code for the City of Roanoke.

**NOW, THEREFORE, BE IT ORDAINED BY THE CITY COUNCIL OF THE CITY OF ROANOKE, TEXAS:**

**SECTION 1.  
FINDINGS INCORPORATED**

The findings set forth above are incorporated into the body of this Ordinance as if fully set forth herein.

**SECTION 2.  
AMENDMENT**

Chapter 3, Article 3.100, of the Code of Ordinances of the City of Roanoke, Texas, entitled "International Codes Adopted," is hereby amended by repealing in its entirety Section 3.104 entitled "International Plumbing Code Adopted" and replacing it with a new Section 3.104 entitled "International Plumbing Code Adopted," which shall read as follows:

**"Sec. 3.104. International Plumbing Code Adopted.**

- (a) *Adoption.* The *International Plumbing Code*, 2024 edition, is hereby adopted and designated as the Plumbing Code for the City of Roanoke, Texas. A copy of the 2024 Edition of the *International Plumbing Code* is on file in the office of the city secretary.
- (b) *Local Amendments.* The following provisions, attached hereto as **Exhibit A** of this

Ordinance, are local amendments to the 2024 Edition of the *International Plumbing Code*. Each provision in this subsection is a substitute for the identically numbered provision contained in the 2024 Edition of the *International Plumbing Code* or is an additional provision added to the 2024 Edition of the *International Plumbing Code*.

**SECTION 3.  
SEVERABILITY CLAUSE**

It is hereby declared to be the intention of the City Council that the phrases, clauses, sentences, paragraphs and sections of this Ordinance are severable, and if any phrase, clause, sentence, paragraph or section of this Ordinance shall be declared unconstitutional by the valid judgment or decree of any court of competent jurisdiction, such unconstitutionality shall not affect any of the remaining phrases, clauses, sentences, paragraphs and sections of this Ordinance, since the same would have been enacted by the City Council without the incorporation of this Ordinance of any such unconstitutional phrase, clause, sentence, paragraph or section.

**SECTION 4.  
REPEALER CLAUSE**

Any provision of any prior ordinance of the City whether codified or uncodified, which are in conflict with any provision of this Ordinance, are hereby repealed to the extent of the conflict, but all other provisions of the ordinances of the City whether codified or uncodified, which are not in conflict with the provisions of this Ordinance, shall remain in full force and effect.

**SECTION 5.  
PENALTY CLAUSE**

Any person, firm, or corporation violating any of the provisions or terms of this Ordinance shall be guilty of a misdemeanor and upon conviction, shall be fined a sum not to exceed \$2,000.00 for each offense, and each and every violation or day such violation shall continue or exist, shall be deemed a separate offense.

**SECTION 6.  
PUBLICATION CLAUSE**

The City Secretary of the City is hereby directed to publish in the official newspaper of the City the caption, penalty clause, and effective date clause of this Ordinance as required by law.

**SECTION 7.  
EFFECTIVE DATE**

This Ordinance shall become effective immediately upon its passage and publication as required by law.

**PASSED, APPROVED AND ADOPTED** by the City Council of the City of Roanoke, Texas, on this June 23, 2026.

**APPROVED:**

\_\_\_\_\_  
Carl E. Gierisch, Jr., Mayor

**ATTEST:**

\_\_\_\_\_  
Lindsay Rawlinson, City Secretary

**APPROVED AS TO FORM:**

\_\_\_\_\_  
Jeff Moore, City Attorney

## Exhibit A

### Local Amendments to the *International Plumbing Code*

#### **Recommended Amendments to the 2024 International Plumbing Code** North Central Texas Council of Governments Region

The following sections, paragraphs, and sentences of the *2024 International Plumbing Code* are hereby amended as follows: Standard type is text from the IPC. Underlined type is text inserted. ~~Lined through type is deleted text from the IPC.~~ A double asterisk at the beginning of a section identifies an amendment carried over from the 2021 edition of the code and a triple asterisk identifies a new or revised amendment with the 2024 edition of the code.

Note: Historically NCTCOG has limited Chapter 1 amendments in order to allow each city to insert their local policies and procedures. We now have suggested certain items to be brought to the attention of cities considering adoption of the code that may be of concern to several jurisdictions. **It is still intended to be discretionary to each city to determine which Chapter 1 amendments to include.**

---

**\*\*Section 102.8; change to read as follows:**

**102.8 Referenced codes and standards.** The codes and standards referenced in this code shall be those that are listed in Chapter 15 and such codes, when specifically adopted, and standards shall be considered as part of the requirements of this code to the prescribed extent of each such reference and as further regulated in Section 102.8.1 and 102.8.2. Whenever amendments have been adopted to the referenced codes and standards, each reference to said code and standard shall be considered to reference the adopted amendments. Any reference to NFPA 70 shall mean the National Electrical Code as adopted.

**Exception:** Where enforcement of a code provision would violate the conditions of the listing of the *equipment* or *appliance*, the conditions of the listing and the manufacturer's installation instruction shall apply.

*(Reason: Legal wording to recognize locally adopted codes and amendments adopted with referenced codes.)*

---

**\*\*Section 305; change to read as follows:**

**305.1 Protection against contact.** Metallic piping, except for cast iron, ductile iron and galvanized steel, shall not be placed in direct contact with steel framing members, concrete or cinder walls and floors or other masonry. Metallic piping shall not be placed in direct contact with corrosive soil. Where sheathing is used to prevent direct contact, the sheathing shall have a thickness of not less than 0.008 inch (8 mil) (0.203 mm) and the sheathing shall be made of approved material plastic. Where sheathing protects

pipng that penetrates concrete or masonry walls or floors, the sheathing shall be installed in a manner that allows movement of the piping within the sheathing.

*(Reason: Allows for other materials to be accepted.)*

**\*\*Section 305.4.1; changed to read as follows:**

**305.4.1 Sewer depth.** ~~Building sewers that connect to private sewage disposal systems shall be a minimum of [number] inches (mm) below finished grade at the point of septic tank connection.~~ Building sewers shall be a minimum of 12 inches (304 mm) below grade.

*(Reason: Provides sewer depth that is common in this region. Deleted reference to private sewage disposal because a private sewage disposal code is not typically adopted in this region.)*

**\*\*\*Section 306.2.5; added to read as follows:**

**\*\*\*306.2.5 Plastic sewer and DWV piping installation.** Plastic sewer and DWV piping installed underground shall be installed in accordance with the manufacturer's installation instructions and ASTM D2321. Trench width shall be controlled to not exceed the outside pipe diameter plus 16 inches or in a trench which has a controlled width equal to the nominal diameter of the diameter of the piping multiplied by 1.25 plus 12 inches. The piping shall be bedded in 4 inches of granular fill and then backfilled compacting the side fill in 6-inch layers on each side of the piping. The compaction shall be to a minimum of 85 percent standard proctor density and extend to a minimum of 6 inches above the top of the pipe.

*(Reason: To follow manufacturer backfill requirements and to be clear to Inspectors out in the field.)*

**\*\*\*Section 403.1; add a second paragraph to read as follows:**

**403.1 Minimum number of fixtures.** Plumbing fixtures shall be proved in the minimum number as shown in Table 403.1, based on the actual use of the building or space. Uses not shown in Table 403.1 shall be considered individually by the Code Official. The number of occupants shall be determined by the *International Building Code*.

In other than E Occupancies, the minimum number of fixtures in Tabel 403.1 may be lowered, if requested in writing, by the applicant stating reasons for a reduction number and approved by the Building Official.

*(Reason: To allow flexibility for designers to consider specific occupancy needs. To be consistent with the International Building Code.)*

**\*\*\* Table 403.1; add footnote g to read as follows:**

g. Drinking fountains are not required in M Occupancies with an occupant load of 100 or less, B Occupancies with an occupant load of 25 or less, and for dining and/or drinking establishments.

*(Reason: To allow flexibility for designer to consider specific occupancy needs.)*

**\*\*\*Section 413.4; change to read as follows:**

**413.4 Required location for floor drains ~~Public laundries and central washing facilities.~~** Floor drains shall be installed in the following areas:

1. In public laundries and in the central washing facilities of multiple family dwellings, the rooms containing automatic clothes washers shall be provided with floor drains located to readily drain the entire floor area. Such drains shall have a minimum outlet of not less than 3 inches (76 mm) in diameter.
2. Commercial kitchens.  
**Exception:** In lieu of floor drains in commercial kitchens, the Code Official may accept floor sinks.
3. Public restrooms.
4. Closets containing mop/service sinks.

*(Reason: To make it more compatible with local health code practices and protection of facilities.)*

**\*\*\*Section 502.3; change to read as follows:**

**502.3 Water heaters installed in attics.** (Remain the same) As a minimum access to the attic space shall be provided by one of the following:

1. A permanent stair.
2. A pull-down stair rated for 300 lb. minimum.
3. An access door from an upper floor level.

*(Reason: To recognize regional practices.)*

**\*\*Section 608.17.5; change to read as follows:**

**608.17.5 Connections to lawn irrigation systems.** The potable water supply to lawn irrigation systems shall be protected against backflow by an atmospheric-type vacuum breaker, a pressure-type vacuum breaker, a double-check assembly or a reduced pressure principal backflow preventer. A valve shall not be installed downstream from an atmospheric vacuum breaker. Where chemicals are introduced into the system, the potable water supply shall be protected against backflow by a reduced pressure principal backflow preventer.

*(Reason: To recognize regional practices.)*

**\*\*Section 703.6; Combined sanitary and storm public sewer. Delete**

*(Reason: not a standard practice in this region)*

**\*\*Section 704.5; added to read as follows:**

**704.5 Single stack fittings.** Single stack fittings with internal baffle, PVC schedule 40 or cast-iron single stack shall be designed by a registered engineer and comply to a national recognized standard.

*(Reason: to allow owners, installers, inspectors, and design professionals to readily identify product markers to determine they meet all required standards.)*

**\*\*Section 712.4.3; add Section 712.4.3 to read as follows:**

**712.4.3 Dual Pump System.** All sumps shall be automatically discharged and, when in any “public use” occupancy where the sump serves more than 10 fixture units, shall be provided with dual pumps or ejectors arranged to function independently in case of overload or mechanical failure. For storm drainage sumps and pumping systems, see Section 1113.

*(Reason: To address dual pump system. To provide reference for storm drainage systems.)*

**\*\*\*Section 903.1.1; change to read as follows:**

**903.1.1 Roof extension unprotected.** Open vent pipes that extend through a roof shall terminate not less than six (6) inches (152 mm) above the roof.

*(Reason: To provide regional guidelines on standard installation methods for this area.)*

**\*\*Section 1109; Combined Sanitary and Storm Public Sewer: delete this section.**

*(Reason: not a standard practice in this region)*

**\*\*\*Section 1202.1; delete Exceptions 1 and 2.**

*(Reason: State law already specifies that Med Gas systems must comply with NFPA 99.)*

**\*\*\*Chapter 15; ASTM D2321; added to Referenced Standards**

ASTM D2321 - Underground Installation of Thermoplastic Pipe for Sewers and Other Gravity-Flow Applications.

306.2.5

(Reason: To add the reference standard as specified in the amendments.)

---

**END**



## AGENDA ITEM

TO: Mayor and City Council

SUBJECT: 2024 edition of the International Property Maintenance Code

MEETING DATE: June 23, 2026

DEPARTMENT: Planning

---

### ITEM SUMMARY:

Consideration and action on approval of Ordinance No. 2026-132, approving the 2024 edition of the International Property Maintenance Code and local amendments thereto.

### INFORMATION:

### STAFF RECOMMENDATION:

### SPECIAL CONSIDERATION:

### FINANCIAL CONSIDERATION:

### ATTACHMENTS:

1. Ordinance No. 2026-132 - International Property Maintenance Code - 2024 Edition - No local amendments

**ORDINANCE NO. 2026-132**

**AN ORDINANCE OF THE CITY COUNCIL OF THE CITY OF ROANOKE, TEXAS, AMENDING CHAPTER 3, ARTICLE 3.100 OF THE CODE OF ORDINANCES OF THE CITY OF ROANOKE, TEXAS, ENTITLED “INTERNATIONAL CODES ADOPTED” BY REPEALING IN ITS ENTIRETY SECTION 3.107 ENTITLED “INTERNATIONAL PROPERTY MAINTENANCE CODE ADOPTED,” AND REPLACING IT WITH A NEW SECTION 3.107 ENTITLED “INTERNATIONAL PROPERTY MAINTENANCE CODE ADOPTED,” BY ADOPTING THE 2024 EDITION OF THE *INTERNATIONAL PROPERTY MAINTENANCE CODE*; PROVIDING A PENALTY CLAUSE; PROVIDING A SEVERABILITY CLAUSE; PROVIDING A REPEALER CLAUSE; AND PROVIDING FOR AN EFFECTIVE DATE.**

**WHEREAS**, the City Council of the City of Roanoke, Texas, is of the opinion that the 2024 Edition of the *International Property Maintenance Code* should be adopted as the Property Maintenance Code for the City of Roanoke.

**NOW, THEREFORE, BE IT ORDAINED BY THE CITY COUNCIL OF THE CITY OF ROANOKE, TEXAS, THAT:**

**SECTION 1.  
FINDINGS INCORPORATED**

The findings set forth above are incorporated into the body of this Ordinance as if fully set forth herein.

**SECTION 2.  
AMENDMENT**

Chapter 3, Article 3.100, of the Code of Ordinances of the City of Roanoke, Texas, entitled “International Codes Adopted,” is hereby amended by repealing in its entirety Section 3.107 entitled “International Property Maintenance Code Adopted” and replacing it with a new Section 3.107 entitled “International Property Maintenance Code Adopted,” which shall read as follows:

**“Sec. 3.107. International Property Maintenance Code Adopted.**

- (a) *Adoption.* The *International Property Maintenance Code*, 2024 edition, is hereby adopted and designated as the Property Maintenance Code for the City of Roanoke, Texas. A copy of the 2024 Edition of the *International Property Maintenance Code* is on file in the office of the city secretary.”

**SECTION 3.  
SEVERABILITY CLAUSE**

It is hereby declared to be the intention of the City Council that the phrases, clauses, sentences, paragraphs and sections of this Ordinance are severable, and if any phrase, clause, sentence, paragraph or section of this Ordinance shall be declared unconstitutional by the valid judgment or decree of any court of competent jurisdiction, such unconstitutionality shall not affect any of the remaining phrases, clauses, sentences, paragraphs and sections of this Ordinance, since the same would have been enacted by the City Council without the incorporation of this Ordinance of any such unconstitutional phrase, clause, sentence, paragraph or section.

**SECTION 4.  
REPEALER CLAUSE**

Any provision of any prior ordinance of the City whether codified or uncodified, which are in conflict with any provision of this Ordinance, are hereby repealed to the extent of the conflict, but all other provisions of the ordinances of the City whether codified or uncodified, which are not in conflict with the provisions of this Ordinance, shall remain in full force and effect.

**SECTION 5.  
PENALTY CLAUSE**

Any person, firm, or corporation violating any of the provisions or terms of this Ordinance shall be guilty of a misdemeanor and upon conviction, shall be fined a sum not to exceed \$2,000.00 for each offense, and each and every violation or day such violation shall continue or exist, shall be deemed a separate offense.

**SECTION 6.  
PUBLICATION CLAUSE**

The City Secretary of the City is hereby directed to publish in the official newspaper of the City the caption, penalty clause, and effective date clause of this Ordinance as required by law.

**SECTION 7.  
EFFECTIVE DATE**

This Ordinance shall become effective immediately upon its passage and publication as required by law.

**PASSED, APPROVED AND ADOPTED** by the City Council of the City of Roanoke, Texas, on this June 23, 2026.

**APPROVED:**

\_\_\_\_\_  
Carl E. Gierisch, Jr., Mayor

**ATTEST:**

\_\_\_\_\_  
Lindsay Rawlinson, City Secretary

**APPROVED AS TO FORM:**

\_\_\_\_\_  
Jeff Moore, City Attorney



## AGENDA ITEM

TO: Mayor and City Council

SUBJECT: 2024 edition of the International Residential Code

MEETING DATE: June 23, 2026

DEPARTMENT: Planning

---

### ITEM SUMMARY:

Consideration and action on approval of Ordinance No. 2026-133 approving the 2024 edition of the International Residential Code and local amendments thereto.

### INFORMATION:

North Central Texas Council of Governments - Regional Codes Coordinating Committee and its five advisory boards conducted multiple meetings to review the latest editions of the model codes and develop regional amendments. Their review and recommendations are endorsed by NCTCOG's Executive Board. NCTCOG encourages jurisdictions in North Central Texas to adopt the following model construction codes along with their respective regional amendments as expeditiously as their local code adoption process will allow.

NCTCOG issued a memorandum to jurisdictions in North Central Texas to adopt the code updates on May 1, 2025.

### STAFF RECOMMENDATION:

Staff recommends approval.

### SPECIAL CONSIDERATION:

### FINANCIAL CONSIDERATION:

### ATTACHMENTS:



## AGENDA ITEM

1. Ordinance No. 2026-133 - International Residential Code - 2024 Edition - with local amendments

**ORDINANCE NO. 2026-133**

**AN ORDINANCE OF THE CITY COUNCIL OF THE CITY OF ROANOKE, TEXAS, AMENDING CHAPTER 3, ARTICLE 3.100 OF THE CODE OF ORDINANCES OF THE CITY OF ROANOKE, TEXAS, ENTITLED “INTERNATIONAL CODES ADOPTED” BY REPEALING IN ITS ENTIRETY SECTION 3.106 ENTITLED “INTERNATIONAL RESIDENTIAL CODE ADOPTED,” AND REPLACING IT WITH A NEW SECTION 3.106 ENTITLED “INTERNATIONAL RESIDENTIAL CODE ADOPTED,” BY ADOPTING THE 2024 EDITION OF THE *INTERNATIONAL RESIDENTIAL CODE*, AND LOCAL AMENDMENTS TO THE *INTERNATIONAL RESIDENTIAL CODE*; PROVIDING A PENALTY CLAUSE; PROVIDING A SEVERABILITY CLAUSE; PROVIDING A REPEALER CLAUSE; AND PROVIDING FOR AN EFFECTIVE DATE.**

**WHEREAS**, the City Council of the City of Roanoke, Texas, is of the opinion that the 2024 Edition of the *International Residential Code*, along with local amendments hereto, should be adopted as the Residential Code for the City of Roanoke.

**NOW, THEREFORE, BE IT ORDAINED BY THE CITY COUNCIL OF THE CITY OF ROANOKE, TEXAS, THAT:**

**SECTION 1.  
FINDINGS INCORPORATED**

The findings set forth above are incorporated into the body of this Ordinance as if fully set forth herein.

**SECTION 2.  
AMENDMENT**

Chapter 3, Article 3.100, of the Code of Ordinances of the City of Roanoke, Texas, entitled “International Codes Adopted,” is hereby amended by repealing in its entirety Section 3.106 entitled “International Residential Code Adopted” and replacing it with a new Section 3.106 entitled “International Residential Code Adopted,” which shall read as follows:

**“Sec. 3.106. International Residential Code Adopted.**

- (a) *Adoption.* The *International Residential Code*, 2024 edition, is hereby adopted and designated as the Residential Code for the City of Roanoke, Texas. A copy of the 2024 Edition of the *International Residential Code* is on file in the office of the city secretary.
- (b) *Local Amendments.* The following provisions, attached hereto as **Exhibit A** of this

Ordinance, are local amendments to the 2024 Edition of the *International Residential Code*. Each provision in this subsection is a substitute for the identically numbered provision contained in the 2024 Edition of the *International Residential Code* or is an additional provision added to the 2024 Edition of the *International Residential Code*.

**SECTION 3.  
SEVERABILITY CLAUSE**

It is hereby declared to be the intention of the City Council that the phrases, clauses, sentences, paragraphs and sections of this Ordinance are severable, and if any phrase, clause, sentence, paragraph or section of this Ordinance shall be declared unconstitutional by the valid judgment or decree of any court of competent jurisdiction, such unconstitutionality shall not affect any of the remaining phrases, clauses, sentences, paragraphs and sections of this Ordinance, since the same would have been enacted by the City Council without the incorporation of this Ordinance of any such unconstitutional phrase, clause, sentence, paragraph or section.

**SECTION 4.  
REPEALER CLAUSE**

Any provision of any prior ordinance of the City whether codified or uncoded, which are in conflict with any provision of this Ordinance, are hereby repealed to the extent of the conflict, but all other provisions of the ordinances of the City whether codified or uncoded, which are not in conflict with the provisions of this Ordinance, shall remain in full force and effect.

**SECTION 5.  
PENALTY CLAUSE**

Any person, firm, or corporation violating any of the provisions or terms of this Ordinance shall be guilty of a misdemeanor and upon conviction, shall be fined a sum not to exceed \$2,000.00 for each offense, and each and every violation or day such violation shall continue or exist, shall be deemed a separate offense.

**SECTION 6.  
PUBLICATION CLAUSE**

The City Secretary of the City is hereby directed to publish in the official newspaper of the City the caption, penalty clause, and effective date clause of this Ordinance as required by law.

**SECTION 7.  
EFFECTIVE DATE**

This Ordinance shall become effective immediately upon its passage and publication as required by law.

**PASSED, APPROVED AND ADOPTED** by the City Council of the City of Roanoke, Texas, on this June 23, 2026.

**APPROVED:**

\_\_\_\_\_  
Carl E. Gierisch, Jr., Mayor

**ATTEST:**

\_\_\_\_\_  
Lindsay Rawlinson, City Secretary

**APPROVED AS TO FORM:**

\_\_\_\_\_  
Jeff Moore, City Attorney

## Exhibit A

### Local Amendments to the *International Residential Code*

#### **Recommended Amendments to the 2024 International Residential Code** North Central Texas Council of Governments Region

The following sections, paragraphs, and sentences of the *2024 International Residential Code* are hereby amended as follows: Standard type is text from the IRC. Underlined type is text inserted. ~~Lined through type is deleted text from IRC.~~ A double asterisk at the beginning of a section identifies an amendment carried over from the 2021 edition of the code and a triple asterisk identifies a new or revised amendment with the 2024 code.

In 2009, **the State Legislature enacted SB 1410 prohibiting cities from enacting fire sprinkler mandates in residential dwellings.** However, jurisdictions with ordinances that required sprinklers for residential dwellings prior to and enforced before January 1, 2009, may remain in place. Reference; Section R313 Automatic Fire Sprinkler Systems.

The energy provisions in IRC Chapter 11 is deleted in its entirety.

**Reference the 2024 IECC for energy code provisions and recommended amendments.**

**\*\*Section R102.4 Referenced codes and standards; change to read as follows:**

**R102.4 Referenced codes and standards.** The *codes*, when specifically adopted, and standards referenced in this *code* shall be considered part of the requirements of this *code* to the prescribed extent of each such reference and as further regulated in Sections R102.4.1 and R102.4.2. Whenever amendments have been adopted to the referenced codes and standards, each reference to said code and standard shall be considered to reference the amendments as well. Any reference made to NFPA 70 or the *Electrical Code* shall mean the *Electrical Code* as adopted.

*(Reason: Legal wording to recognize locally adopted codes and amendments adopted with referenced codes.)*

**\*\*Section R104.2.3.1 Flood Hazard areas; delete this section.**

*(Reason: Flood hazard ordinances may be administered by other departments within the city.)*

**\*\*Section R104.3.1 & R106.1.4; delete these sections regarding flood hazards.**

*(Reason: Floodplain provisions are addressed locally.)*

**\*\*\*Section R104.7 to read as follows:**

**R104.7 Official records.**

The building official shall keep official records as required in Sections R104.7.1 through R104.7.5. Such official records shall be retained for as long as the building or structure to which such records relate remains in existence, unless otherwise provided by other regulations.

*(Reason: Removed for not less than 5 years to comply with state law.)*

**\*\*\*R105.3 Application for permit. delete item # 5 – regarding valuation of work**

*(Reason: 2019 State Legislation HB 852 prohibits residential permit fee calculation using valuation of work.)*

**\*\*\*Section R110.1 Use and change of occupancy; Change to read**

A building or structure shall not be used or occupied in whole or in part, and a change of occupancy of a building or structure or portion thereof shall not be made, until the building official has issued a ~~certificate of occupancy~~ an approval therefore as provided herein. Issuance of a ~~certificate of occupancy~~ an approval shall not be construed as an approval of a violation of the provisions of this code or of other ordinances of the jurisdiction. Certificates presuming to give authority to violate or cancel the provisions of this code or other ordinances of the jurisdiction shall not be valid.

*(Reason: Issuing CO's for residences is not a common practice in the area.)*

**\*\*\*Section R110.2 Certificate issued. delete the entire section.**

*(Reason: Issuing CO's for residences is not a common practice in the area.)*

**\*\*\* Section R110.3 Temporary occupancy; Change to read**

The building official is authorized to issue a temporary ~~certificate of occupancy~~ approval before the completion of the entire work covered by the permit, provided that such portion or portions shall be occupied safely. The building official shall set a time period during which the temporary ~~certificate of occupancy~~ approval is valid.

*(Reason: Issuing CO's for residences is not a common practice in the area.)*

**\*\*\* Section R110.4 Revocation; Change to read**

The building official is authorized to suspend or revoke a ~~certificate of occupancy~~ approval issued under the provisions of this code, in writing, wherever the ~~certificate~~ approval is issued in error, or on the basis of incorrect information supplied, or where it is determined

that the building or structure or portion thereof is in violation of the provisions of this code or other ordinance of the jurisdiction.

*(Reason: Issuing CO's for residences is not a common practice in the area.)*

**\*\*Section R202 Definitions; change definition of "Townhouse Unit" to read as follows:**

**TOWNHOUSE UNIT.** A single-family dwelling unit separated by property lines in a townhouse that extends from foundation to roof and that has a yard or public way on not less than two sides.

*(Reason: To distinguish Townhouse Units within a Townhouse building on separate lots allowing construction regulations using the IRC.)*

**\*\*\*Table R301.2 Climatic and Geographic Design Criteria; fill in as follows:  
Delete remainder of table Manual J Design Criteria and footnote N**

GROUND SNOW LOAD <sup>o</sup>	WIND DESIGN				SEISMIC DESIGN CATEGORY <sup>r</sup>	SUBJECT TO DAMAGE FROM			Winter Design Temp	ICE BARRIER UNDER-LAYMENT <sup>h</sup>	FLOOD HAZARDS <sup>g</sup>	AIR FREEZING INDEX <sup>i</sup>	MEAN ANNUAL TEMP <sup>j</sup>
	SPEED <sup>d</sup> (MPH)	Topographic Effects <sup>k</sup>	Special wind Region <sup>l</sup>	Windborne Debris Zone <sup>m</sup>		Weathering <sup>a</sup>	Frost Line Depth <sup>b</sup>	Termite <sup>c</sup>					
9 lb/ft <sup>2</sup>	105 (3 sec-gust)/ 33 ft.above ground Exposure C	No	No	No	A	Moderate	6"	Very Heavy	22 <sup>o</sup> F	No	Local Code	150	64.9 <sup>o</sup> F

*(Reason: To promote regional uniformity. Manual J is utilized by third party and not part of performed plan reviews. This is reference table only, not needed.)*

**\*\*Section R302.1 Exterior walls; add exception #6 to read as follows:**

**Exceptions:** {previous exceptions unchanged}

6. Open non-combustible carport structures may be constructed when also approved within adopted ordinances.

*(Reason: Refers to other ordinances, such as zoning ordinances.)*

**\*\*Section R302.2.6 Structural independence; delete exception #6:**

**Exceptions:** {previous exceptions unchanged}

6. ~~Townhouse units protected by an automatic fire sprinkler system complying with Section P2904 or NFPA 13D.~~

*(Reason: To remain consistent with separated townhouse units and property lines.)*

**\*\*Section R302.5.1 Opening protection; change to read as follows:**

**R302.5.1 Opening protection.** Openings from a private garage directly into a room used for sleeping purposes shall not be permitted. Other openings between the garage and dwelling unit shall be equipped with solid wood doors not less than 1-3/8 inches (35 mm) in thickness, solid or honeycomb-core steel doors not less than 1-3/8 inches (35 mm) thick, or 20-minute fire-rated doors. ~~Doors shall be self-latching and equipped with a self-closing or automatic closing device.~~

*(Reason: Absence of data linking self-closing devices to increased safety. Self-closing devices often fail to close the door entirely.)*

**\*\*Section R306 Flood Resistant Construction; deleted entire section.**

*(Reason: Floodplain hazard ordinances may be administered by other departments within the city.)*

**\*\*Section R309.2 One- and two-family dwellings automatic sprinkler systems; Delete this section and subsection in their entirety.**

*(Reason: In 2009, the State Legislature enacted SB 1410, amending section 1301.551 subsection I of the occupation code, prohibiting cities from enacting fire sprinkler mandates one- or two-family dwellings only. However, jurisdictions with ordinances that required sprinklers for one- or two-family dwellings prior to and enforced before January 1, 2009, may remain in place.)*

**\*\*Section R325.2 Bathrooms, Exception; amend to read as follows:**

**Exception:** ~~{existing text unchanged}~~ Spaces containing only a water closet or water closet and a lavatory may be ventilated with an approved mechanical recirculating fan or similar device designed to remove odors from the air.

*(Reason: Consistent with common local practice as recirculating fans are recognized as acceptable air movement.)*

**\*\*\*R327.3 Blocking Locations; add to read as follows:**

**R327.3 Blocking locations.** Required at one toilet at grade level with blocking installed at rear wall and, if available, one wall adjacent to toilet and at one tub or shower at grade level. Blocking as shown in Figure R327.3.

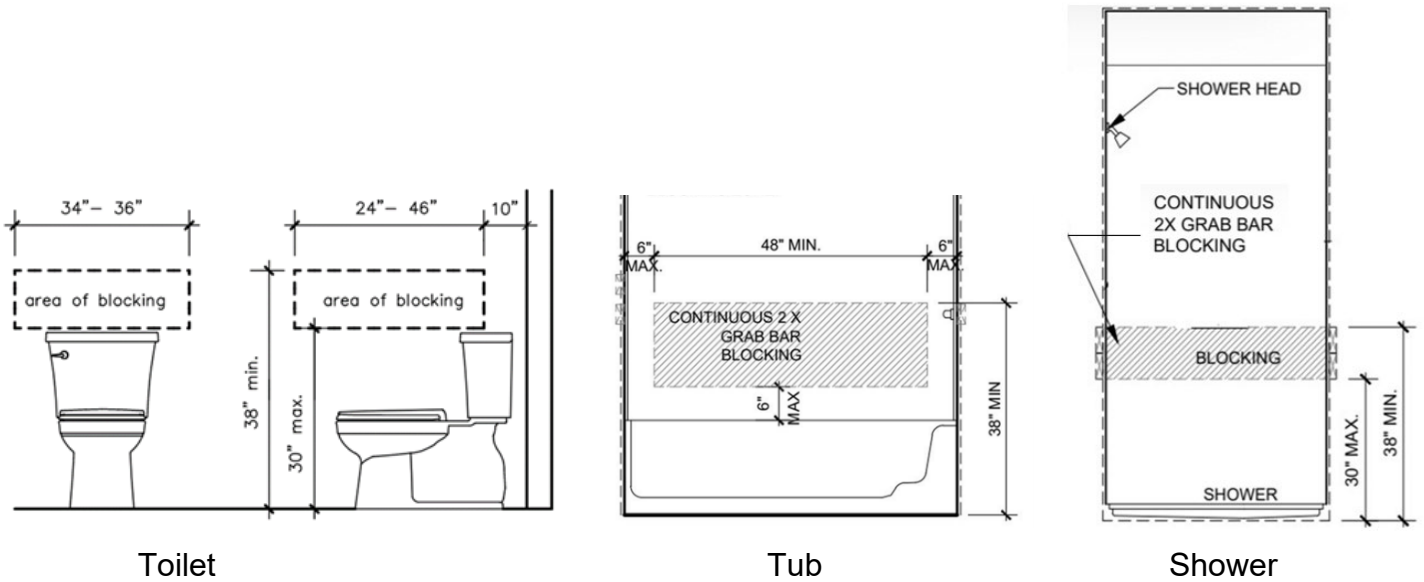

Fig R327.3

*(Reason: Blocking at initial construction allows for ease of use for future grab bar installation if desired for homeowners. Ties into Dallas Builders Association of Universal Design Elements concepts for CAPS (Certified Aging in Place Specialists) professionals.)*

**\*\*\*R327.4 Wall Blocking; add to read as follows:**

**R327.4 Wall Blocking.** Blocking may be 1/2" plywood or 2 x solid wood blocking or equivalent, flush with wall as shown in Figure R327.4.

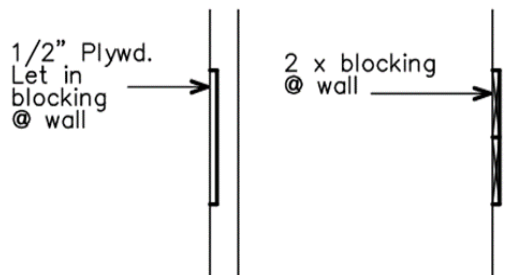

Fig R327.4

*(Reason: Blocking at initial construction allows for ease of use for future grab bar installation if desired for homeowners. Ties into Dallas Builders Association of Universal Design Elements concepts for CAPS (Certified Aging in Place Specialists) professionals.)*

**\*\*Section 328.1.1; add to read as follows:**

**Section 328.1.1 Adjacency to Structural Foundation.** Depth of the swimming pool and spa shall maintain a ratio of 1:1 from the nearest building foundation or footing of a retaining wall.

**Exception:** A sealed engineered design drawing of the proposed new structure shall be submitted for approval.

*(Reason: To clarify specific distances for pools and spas.)*

**\*\*Section R401.2; add a new paragraph following the existing paragraph to read as follows.**

**Section R401.2. Requirements.** {existing text unchanged} ...

Every foundation and/or footing, or any size addition to an existing post-tension foundation, regulated by this code shall be designed and sealed by a Texas-registered engineer.

*(Amendment to 2021 IRC carried forward to 2024 IRC.)*

**\*\*Section R602.6.1; amend the following:**

**R602.6.1 Drilling and notching of top plate.** When piping or ductwork is placed in or partly in an exterior wall or interior load-bearing wall, necessitating cutting, drilling or notching of the top plate by more than 50 percent of its width, a galvanized metal tie not less than 0.054 inch thick (1.37 mm) (16 Ga) and ~~4 ½ inches (38) mm~~ 5 inches (127 mm) wide shall be fastened across and to the plate at each side of the opening with not less than eight 10d (0.148 inch diameter) having a minimum length of 1 ½ inches (38 mm) at each side or equivalent. Fasteners will be offset to prevent splitting of the top plate material. The metal tie must extend a minimum of 6 inches past the opening. See figure R602.6.1. {remainder unchanged}

*(Amendment to 2021 IRC carried forward to 2024 IRC.)*

**\*\*Figure R602.6.1; delete the figure and insert the following figure:**

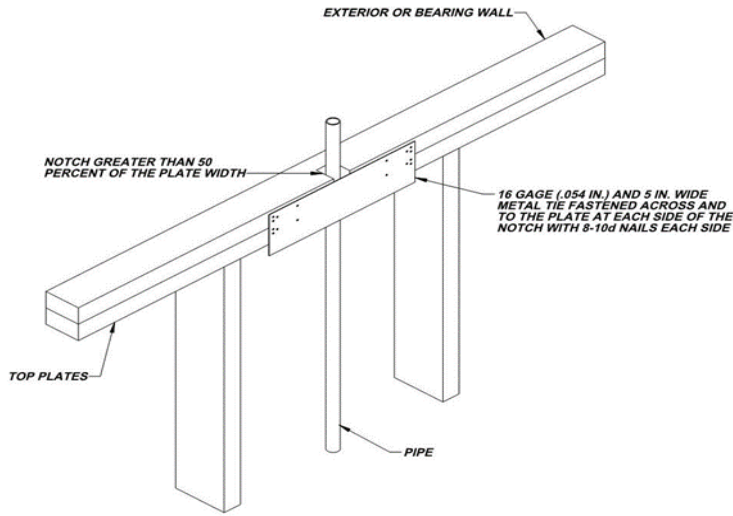

*(Amendment to 2021 IRC carried forward to 2024 IRC also provides additional assurance of maintaining the integrity of the framing by spreading the nailing pattern.)*

**\*\*\*Table R603.7(2); change footnotes to read as follows:**

- a. All screw sizes shown are minimum size, not to exceed 2 sizes larger.
- b. {delete}
- c. {delete}
- d. {unchanged}

*(Clarifies not to allow any larger or number of fasteners. Larger and more fasteners will derogate (tear down) the header material. Eliminating footnotes b and c makes it easier for contractors to follow.)*

**\*\*Add section R703.8.4.1.2 Veneer Ties for Wall Studs; to read as follows:**

**R703.8.4.1.2 Veneer Ties for Wall Studs.** In stud framed exterior walls, all ties may be anchored to studs as follows:

1. When studs are 16 in (407 mm) o.c., stud ties shall be spaced no further apart than 24 in (737 mm) vertically starting approximately 12 in (381 mm) from the foundation; or
2. When studs are 24 in (610 mm) o.c., stud ties shall be spaced no further apart than 16 in (483 mm) vertically starting approximately 8 in (254 mm) from the foundation.

*(This amendment had been a carryover amendment for years to provide clear instruction for placement of brick ties. It is now retained with changes to reflect its correct placement and use for clarity when attachment to framing lumber (studs). It should remain for those purposes.)*

**\*\*\*Section R1005.7 Factory-built chimney offsets; change to read as follows:**

**R1005.7 Factory-built chimney offsets.**

Where a factory-built chimney assembly incorporates offsets or where a fireplace manufacturer's instructions do not address factory-built chimney offsets, no part of

the chimney shall be at an angle of more than 30 degrees (0.52 rad) from vertical at any point in the assembly and the chimney assembly shall not include more than four elbows. *(Eliminates R1005.9 Factory-built chimney offsets. which has the same requirements for offsets and same title.)*

**\*\*\*Delete Section R1005.9 Factory-built chimney offsets.**

*(Eliminate R1005.9 Factory-built chimney offsets. which has same requirements for offsets and same title as R1005.7)*

**\*\* Chapter 11 [RE] – Energy Efficiency is deleted in its entirety; Reference the 2024 IECC for energy code provisions and recommended amendments.**

*(Reason: The recommended energy code changes from the Energy and Green Advisory Board update the amendments for Chapter 11. The 2024 International Energy Conservation Code should be referenced for residential energy provisions. This approach simply minimizes the number of amendments to the IRC.)*

**\*\*Section M1305.1.2; change to read as follows:**

**M1305.1.2 Appliances in attics.** Attics containing appliances shall be provided . . . {bulk of paragraph unchanged} . . . side of the appliance. The clear access opening dimensions shall be a minimum of 20 inches by 30 inches (508 mm by 762 mm), and large enough to allow removal of the largest appliance. As a minimum, for access to the attic space, provide one of the following:

1. A permanent stair.
2. A pull down stair with a minimum 300 lb (136 kg) capacity.
3. An access door from an upper floor level.

**Exceptions:**

1. The passageway and level service space are not required where the *appliance* is capable of being serviced and removed through the required opening with the approval of the code official.
2. Where the passageway is unobstructed and not less than 6 feet (1829 mm) high and 22 inches (559 mm) wide for its entire length, the passageway shall be not greater than 50 feet (15,250 mm) in length.

*(Reason: To provide a safe means of accessibility to appliances in attics and to allow for different types of construction limitations. Consistent with regional amendment to IFGC 306.3 and IMC 306.3.)*

**\*\*\*M1401.1.1; is added to read as follows:**

**M1401.1.1 Air conditioning equipment.** All residential dwelling units shall be designed and installed with an air conditioning system with the ability to condition and maintain conditioned air 20 degrees below the ambient outside air temperature in all habitable spaces.

*(Reason: To provide a safe dwelling unit as the ambient temperature can cause life threatening conditions.)*

**\*\*\*Section M1411.9; change to read as follows:**

**M1411.9 Condensate disposal.** Condensate from all cooling coils or evaporators shall be conveyed from the drain pan outlet to an ~~approved place of disposal~~ a sanitary sewer through a trap, by means of a direct or indirect drain. *{remaining text unchanged}*

*(Reason: Reflects regional practice and to reduce excessive runoff into storm drains.)*

**\*\*\*Section M1411.9.1, Items 3 and 4; add text to read as follows:**

**M1411.9.1 Auxiliary and secondary drain systems.** *{bulk of paragraph unchanged}*

1. *{text unchanged}*
2. *{text unchanged}*
3. An auxiliary drain pan... *{bulk of text unchanged}*... with Item 1 of this section. A water level detection device may be installed only with prior approval of the building official.
4. A water level detection device... *{bulk of text unchanged}*... overflow rim of such pan. A water level detection device may be installed only with prior approval of the building official.

*(Reason: Reflects standard practice in this area.)*

**\*\*\*Section M1411.9.1.1; add text to read as follows:**

**M1411.9.1.1 Water-level monitoring devices.** On down-flow units ...*{bulk of text unchanged}*... installed in the drain line. A water level detection device may be installed only with prior approval of the building official.

*(Reason: Reflects standard practice in this area.)*

**\*\*M1503.6 Makeup Air Required; amend and add exception as follows:**

**M1503.6 Makeup air required.** Where one or more gas, liquid or solid fuel-burning appliance that is neither direct-vent nor uses a mechanical draft venting system is located within a dwelling unit's air barrier, each exhaust system capable of exhausting in excess

of 400 cubic feet per minute (0.19 m<sup>3</sup>/s) shall be mechanically or passively provided with makeup air at a rate approximately equal to the difference between exhaust air rate and 400 cubic feet per minute. Such makeup air systems shall be equipped with not fewer than one damper complying with [Section M1503.6.2](#).

**Exception:** Makeup air is not required for exhaust systems installed for the exclusive purpose of space cooling and intended to be operated only when windows or other air inlets are open. Where all appliances in the house are of sealed combustion, power-vent, unvented, or electric, the exhaust hood system shall be permitted to exhaust up to 600 cubic feet per minute (0.28 m<sup>3</sup>/s) without providing makeup air. Exhaust hood systems capable of exhausting in excess of 600 cubic feet per minute (0.28 m<sup>3</sup>/s) shall be provided with a makeup air at a rate approximately to the difference between the exhaust air rate and 600 cubic feet per minute.

*(Reason: Exception requires makeup air equaling the amount above and beyond 400 cfm for larger fan which will address concerns related to “fresh” air from the outdoors in hot humid climates creating a burden on HVAC equipment and negative efficiency impacts from back-drafting and wasted energy.)*

**\*\*Section M2005.2; change to read as follows:**

**M2005.2 Prohibited locations.** Fuel-fired water heaters shall not be installed in a room used as a storage closet. Water heaters located in a bedroom or bathroom shall be installed in a sealed enclosure so that *combustion air* will not be taken from the living space. Access to such enclosure may be from the bedroom or bathroom when through a solid door, weather-stripped in accordance with the exterior door air leakage requirements of the *International Energy Conservation Code* and equipped with an *approved self-closing device*. Installation of direct-vent water heaters within an enclosure is not required.

*(Reason: Corresponds with the provisions of IFGC Section 303.3, exception #5.)*

**\*\*Section G2408.3 (305.5)Private Garages; delete this section in its entirety.**

*(Reason: This provision does not reflect standard practice in this area.)*

**\*\*Section G2415.2 (404.2 ) CSST; add a second paragraph to read as follows:**

Both ends of each section of medium pressure gas piping shall identify its operating gas pressure with an *approved tag*. The tags are to be composed of aluminum or stainless steel and the following wording shall be stamped into the tag:

"WARNING: 1/2 to 5 psi gas pressure - Do Not Remove"

*(Reason: To protect homeowners and plumbers.)*

**\*\*Section G2415.12 (404.12) and G2415.12.1 (404.12.1); change to read as follows:**

**G2415.12 (404.12) Minimum burial depth.** Underground *pipng* systems shall be installed a minimum depth of ~~12 inches (305 mm)~~ 18 inches (457 mm) below grade, except as provided for in Section ~~G2415.12.1~~.

**G2415.12.1 (404.12.1) Individual Outdoor Appliances; Delete in its entirety**

*(Reason: To provide increased protection to piping systems.)*

**\*\*Section G2417.1 (406.1); change to read as follows:**

**G2417.1 (406.1) General.** Prior to acceptance and initial operation, all *pipng* installations shall be inspected and *pressure tested* to determine that the materials, design, fabrication, and installation practices comply with the requirements of this code. The permit holder shall make the applicable tests prescribed in Sections 2417.1.1 through 2417.1.5 to determine compliance with the provisions of this code. The permit holder shall give reasonable advance notice to the building official when the piping system is ready for testing. The equipment, material, power and labor necessary for the inspections and test shall be furnished by the permit holder and the permit holder shall be responsible for determining that the work will withstand the test pressure prescribed in the following tests.

*(Reason: To utilize language used in the IPC regarding who is responsible for testing procedures.)*

**\*\*Section G2417.4; change to read as follows:**

**G2417.4 (406.4) Test pressure measurement.** Test pressure shall be measured with a monometer or with a pressure-measuring device designed and calibrated to read, record, or indicate a pressure loss caused by leakage during the pressure test period. The source of pressure shall be isolated before the pressure tests are made. ~~Mechanical gauges used to measure test pressures shall have a range such that the highest end of the scale is not greater than five times the test pressure.~~

*(Reason: To require the use of more accurate diaphragm gauges. Spring gauges do not provide accurate measurement below approximately 17 psig.)*

**\*\*Section G2417.4.1; change to read as follows:**

**G2417.4.1 (406.4.1) Test pressure.** The test pressure to be used shall be no less than 3 psig (20 kPa gauge), or at the discretion of the Code Official, the piping and valves may be tested at a pressure of at least six (6) inches (152 mm) of mercury, measured with a manometer or slope gauge, irrespective of design pressure. Where the test pressure exceeds 125 psig (862 kPa gauge), the test pressure shall not exceed a value that produces a hoop stress in the piping greater than 50 percent of the specified minimum yield strength of the pipe. For tests requiring a pressure of 3 psig, diaphragm gauges shall utilize a dial with a minimum diameter of three and one half inches (3 1/2"), a set hand, 1/10 pound incrementation and pressure range not to exceed 6 psi for tests requiring a pressure of 3 psig. For tests requiring a pressure of 10 psig, diaphragm gauges shall utilize a dial with a minimum diameter of three and one-half inches (3 1/2"), a set hand, a minimum of 2/10 pound incrementation and a pressure range not to exceed 20 psi. For welded piping, and for piping carrying gas at pressures in excess of fourteen (14) inches water column pressure (3.48 kPa) (1/2 psi) and less than 200 inches of water column pressure (52.2 kPa) (7.5 psi), the test pressure shall not be less than ten (10) pounds per square inch (69.6 kPa). For piping carrying gas at a pressure that exceeds 200 inches of water column (52.2 kPa) (7.5 psi), the test pressure shall be not less than one and one-half times the proposed maximum working pressure.

Diaphragm gauges used for testing must display a current calibration and be in good working condition. The appropriate test must be applied to the diaphragm gauge used for testing.

*(Reason: To provide for lesser pressures to coordinate with the use of more accurate diaphragm gauges.)*

**\*\*Section G2417.4.2; change to read as follows:**

**G2417.4.2 (406.4.2) Test duration.** The test duration shall be held for a length of time satisfactory to the *Building Official*, but in no case for ~~be not~~ less than ~~40~~ fifteen (15) minutes. For welded *piping*, and for *piping* carrying gas at pressures in excess of fourteen (14) inches water column pressure (3.48 kPa), the test duration shall be held for a length of time satisfactory to the *Building Official*, but in no case for less than thirty (30) minutes.

*(Reason: To comply with accepted regional practices.)*

**\*\*Section G2420.1 (409.1) add Section G2420.1.4 (409.1.4) to read as follows:**

**G2420.1.4 (409.1.4) Valves in CSST installations.** Shutoff valves installed with corrugated stainless steel (CSST) *piping systems* shall be supported with an approved termination fitting, or equivalent support, suitable for the size of the *valves*, of adequate strength and quality, and located at intervals so as to prevent or damp out excessive

vibration but in no case greater than 12-inches from the center of the valve. Supports shall be installed so as not to interfere with the free expansion and contraction of the system's piping, fittings, and valves between anchors. All valves and supports shall be designed and installed so they will not be disengaged by movement of the supporting piping.

*(Reason: To provide proper security to CSST valves. These standards were established in this region in 1999 when CSST was an emerging technology.)*

**\*\*Section G2420.5.1 (409.5.1); add text to read as follows:**

**G2420.5.1 (409.5.1) Located within the same room.** The shutoff valve...*{bulk of paragraph unchanged}*... in accordance with the appliance manufacturer's instructions. A secondary shutoff valve must be installed within 3 feet (914 mm) of the firebox if appliance shutoff is located in the firebox.

*(Reason: Reflects regional practice and provides an additional measure of convenience and safety.)*

**\*\*Section G2421.1 (410.1); add text and Exception to read as follows:**

**G2421.1 (410.1) Pressure regulators.** A line *pressure regulator* shall be ... *{bulk of paragraph unchanged}*... approved for outdoor installation. Access to regulators shall comply with the requirements for access to appliances as specified in Section M1305.

**Exception:** A passageway or level service space is not required when the regulator is capable of being serviced and removed through the required attic opening.

*(Reason: To require adequate access to regulators.)*

**\*\*Section G2445.2 (621.2); add Exception to read as follows:**

**G2445.2 (621.2) Prohibited use.** One or more *unvented room heaters* shall not be used as the sole source of comfort heating in a *dwelling unit*.

**Exception:** Existing approved unvented room heaters may continue to be used in dwelling units, in accordance with the code provisions in effect when installed, when approved by the Building Official unless an unsafe condition is determined to exist as described in International Fuel Gas Code Section 108.7 of the Fuel Gas Code.

*(Reason: Gives code official discretion.)*

**\*\*Section P2603; add to read as follows:**

**P2603.3 Protection against corrosion.** Metallic piping, except for cast iron, ductile iron and galvanized steel, shall not be placed in direct contact with steel framing members, concrete or cinder walls and floors or other masonry. Metallic piping shall not be placed in direct contact with corrosive soil. Where sheathing is used to prevent direct contact, the sheathing shall have a thickness of not less than 0.008 inch (8 mil) (0.203 mm) and the sheathing shall be made of approved material plastic. Where sheathing protects piping that penetrates concrete or masonry walls or floors, the sheathing shall be installed in a manner that allows movement of the piping within the sheathing.

*(Reason: Allows for other materials to be accepted )*

**\*\*Section P2603.5.1 Sewer Depth; change to read as follows:**

**P2603.5.1 Sewer depth.** Building sewers that connect to private sewage disposal systems shall be a minimum of 12 inches (304 mm) below finished grade at the point of septic tank connection. Building sewers shall be a minimum of 12 inches (304 mm) below grade.

*(Reason: Provides sewer depth that is common in this region. Deleted reference to private sewage disposal because a private sewage disposal code is not typically adopted in this region.)*

**\*\*Section P2604; P2604.1.1 add to read as follows:**

**P2604.1.1 Plastic sewer and DWV piping installation.** Plastic sewer and DWV piping installed underground shall be installed in accordance with the manufacturer’s installation instructions. Trench width shall be controlled to not exceed the outside the pipe diameter plus 16 inches or in a trench which has a controlled width equal to the nominal diameter of the piping multiplied by 1.25 plus 12 inches. The piping shall be bedded in 4 inches of granular fill and then backfilled compacting the side fill in 6-inch layers on each side of the piping. The compaction shall be to minimum of 85 percent standard proctor density and extend to a minimum of 6 inches above the top of the pipe.

*(Reason: To follow manufacturer backfill requirements and to be clear to Inspectors out in the field.)*

**\*\*Section P2801.5.1; change to read as follows:**

**Section P2801.5.1 Pan size and drain.** The pan shall be not less than 1 1/2 inches (38 mm) in depth and shall be of sufficient size and shape to receive all dripping or condensate from the tank or water heater. The pan shall be drained by an indirect waste pipe having a diameter of not less than 3/4 inch (19 mm). Piping for safety pan drains shall be of those materials listed in Table P2906.5.

Multiple pan drains may terminate to a single discharge piping system when approved by the administrative authority and permitted by the manufacturers installation instructions and installed with those instructions. {existing text unchanged}

*(Reason: Regionally accepted practice.)*

**\*\* Section P2804.6.1; change to read as follows:**

**Section P2804.6.1 Requirements for discharge piping.** The discharge piping serving a pressure relief valve, temperature relief valve or combination thereof shall:

1. Not be directly connected to the drainage system.
2. Discharge through an air gap ~~located in the same room as the water heater.~~
3. Not be smaller than the diameter of the outlet of the valve served and shall discharge full size to the air gap.
4. Serve a single relief device and shall not connect to piping serving any other relief device or equipment.

**Exception:** Multiple relief devices may be installed to a single T & P discharge piping system when approved by the administrative authority and permitted by the manufactures installation instructions and installed with those instructions.

5. Discharge ~~to the floor, to the pan serving the water heater or storage tank, to a waste receptor~~ an approved location or to the outdoors.

[remainder unchanged]

*(Reason: To ensure the T&P is ran to the exterior.)*

**\*\*Section P2902.5.3; change to read as follows:**

**P2902.5.3 Lawn irrigation systems.** The potable water supply to lawn irrigation systems shall be protected against backflow by an atmospheric-type vacuum breaker, a pressure-type vacuum breaker, a double-check assembly or a reduced pressure principle backflow preventer. A valve shall not be installed downstream from an atmospheric vacuum breaker. Where chemicals are introduced into the system, the potable water supply shall be protected against backflow by a reduced pressure principle backflow preventer.

*(Reason: To provide clarity.)*

**\*\*Section P3003.9; change to read as follows:**

**P3003.9.2 Solvent cementing.** Joint surfaces shall be clean and free from moisture. A purple primer, ~~or other approved primer,~~ that conforms to ASTM F 656 shall be applied. Solvent cement not purple in color and conforming to ASTM D 2564, CSA B137.3, CSA B181.2 or CSA B182.1 shall be applied to all joint surfaces. The joint shall be made while the cement is wet and shall be in accordance with ASTM D 2855. Solvent cement joints shall be permitted above or below ground.

Exception: A primer is not required where all of the following conditions apply:

- ~~1. The solvent cement used is third party certified as conforming to ASTM D-2564~~
- ~~2. The solvent cement is used only for joining PVC drain, waste, and vent pipe and fittings in not pressure applications in sizes up to and including 4 inches (102mm) in diameter.~~
- ~~3. The joint is made in accordance with ASTM F3328~~

*(Reason: to keep the “process of joining PVC pipe”.)*

**\*\*Section P3111 Combination waste and vent systems; delete this section in its entirety.**

*(Reason: A combination waste and vent system is not approved for use in residential construction.)*

**\*\*Section P3112.2 Vent Connection; delete and replace with the following:**

**P3112.2 Installation.** Traps for island sinks and similar equipment shall be roughed in above the floor and may be vented by extending the vent as high as possible, but not less than the drainboard height and then returning it downward and connecting it to the horizontal sink drain immediately downstream from the vertical fixture drain. The return vent shall be connected to the horizontal drain through a wye-branch fitting and shall, in addition, be provided with a foot vent taken off the vertical fixture vent by means of a wye-branch immediately below the floor and extending to the nearest partition and then through the roof to the open air or may be connected to other vents at a point not less than six (6) inches (152 mm) above the flood level rim of the fixtures served. Drainage fittings shall be used on all parts of the vent below the floor level and a minimum slope of one-quarter (1/4) inch per foot (20.9 mm/m) back to the drain shall be maintained. The return bend used under the drain-board shall be a one (1) piece fitting or an assembly of a forty-five (45) degree (0.79 radius), a ninety (90) degree (1.6 radius) and a forty-five (45) degree (0.79 radius) elbow in the order named. Pipe sizing shall be as elsewhere required in this Code. The island sink drain, upstream of the return vent, shall serve no other fixtures. An accessible cleanout shall be installed in the vertical portion of the foot vent.

*(Reason: To clarify the installation of island venting and to provide a regional guideline on a standard installation method for this region.)*

**END**



## AGENDA ITEM

TO: Mayor and City Council

SUBJECT: 2024 edition of the International Swimming Pool and Spa Code

MEETING DATE: June 23, 2026

DEPARTMENT: Planning

---

### ITEM SUMMARY:

Consideration and action on approval of Ordinance No. 2026-134, approving the 2024 edition of the International Swimming Pool and Spa Code and local amendments thereto.

### INFORMATION:

North Central Texas Council of Governments - Regional Codes Coordinating Committee and its five advisory boards conducted multiple meetings to review the latest editions of the model codes and develop regional amendments. Their review and recommendations are endorsed by NCTCOG's Executive Board. NCTCOG encourages jurisdictions in North Central Texas to adopt the following model construction codes along with their respective regional amendments as expeditiously as their local code adoption process will allow.

NCTCOG issued a memorandum to jurisdictions in North Central Texas to adopt the code updates on May 1, 2025.

### STAFF RECOMMENDATION:

Staff recommends approval.

### SPECIAL CONSIDERATION:

### FINANCIAL CONSIDERATION:



## **AGENDA ITEM**

### **ATTACHMENTS:**

1. Ordinance No. 2026-134 - International Swimming Pool and Spa Code - 2024 Edition - with local amendments

**ORDINANCE NO. 2026-134**

**AN ORDINANCE OF THE CITY COUNCIL OF THE CITY OF ROANOKE, TEXAS, AMENDING CHAPTER 3, ARTICLE 3.100 OF THE CODE OF ORDINANCES OF THE CITY OF ROANOKE, TEXAS, ENTITLED “INTERNATIONAL CODES ADOPTED” BY REPEALING IN ITS ENTIRETY SECTION 3.111 ENTITLED “INTERNATIONAL SWIMMING POOL AND SPA CODE ADOPTED,” AND REPLACING IT WITH A NEW SECTION 3.111 ENTITLED “INTERNATIONAL SWIMMING POOL AND SPA CODE ADOPTED,” BY ADOPTING THE 2024 EDITION OF THE *INTERNATIONAL SWIMMING POOL AND SPA CODE*, AND LOCAL AMENDMENTS TO THE *INTERNATIONAL SWIMMING POOL AND SPA CODE*; PROVIDING A SEVERABILITY CLAUSE; PROVIDING A REPEALER CLAUSE; PROVIDING A PENALTY FOR VIOLATIONS; PROVIDING FOR PUBLICATION IN THE OFFICIAL NEWSPAPER; AND PROVIDING FOR AN EFFECTIVE DATE.**

**WHEREAS**, the City Council of the City of Roanoke, Texas, is of the opinion that the 2024 Edition of the International Swimming Pool and Spa Code, along with local amendments hereto, should be adopted as the International Swimming Pool and Spa Code for the City of Roanoke.

**NOW, THEREFORE, BE IT ORDAINED BY THE CITY COUNCIL OF THE CITY OF ROANOKE, TEXAS, THAT:**

**SECTION 1.  
FINDINGS INCORPORATED**

The findings set forth above are incorporated into the body of this Ordinance as if fully set forth herein.

**SECTION 2.  
AMENDMENT**

Chapter 3, Article 3.100, of the Code of Ordinances of the City of Roanoke, Texas, entitled “International Codes Adopted,” is hereby amended by repealing in its entirety Section 3.111 entitled “International Swimming Pool and Spa Code Adopted” and replacing it with a new Section 3.111 entitled “International Swimming Pool and Spa Code Adopted,” which shall read as follows:

**“Sec. 3.111. International Swimming Pool and Spa Code Adopted.**

- (a) *Adoption.* The *International Swimming Pool and Spa Code*, 2024 edition, is hereby adopted and designated as the International Swimming Pool and Spa Code for the City of Roanoke, Texas. A copy of the 2024 Edition of the *International Swimming Pool and Spa Code* is on file in the office of the city secretary.

- (b) *Local Amendments.* The following provisions, attached hereto as **Exhibit A** of this Ordinance, are local amendments to the 2024 Edition of the *International Swimming Pool and Spa Code*. Each provision in this subsection is a substitute for the identically numbered provision contained in the 2024 Edition of the *International Swimming Pool and Spa Code* or is an additional provision added to the 2024 Edition of the *International Swimming Pool and Spa Code*.

**SECTION 3.  
SEVERABILITY CLAUSE**

It is hereby declared to be the intention of the City Council that the phrases, clauses, sentences, paragraphs and sections of this Ordinance are severable, and if any phrase, clause, sentence, paragraph or section of this Ordinance shall be declared unconstitutional by the valid judgment or decree of any court of competent jurisdiction, such unconstitutionality shall not affect any of the remaining phrases, clauses, sentences, paragraphs and sections of this Ordinance, since the same would have been enacted by the City Council without the incorporation of this Ordinance of any such unconstitutional phrase, clause, sentence, paragraph or section.

**SECTION 4.  
REPEALER CLAUSE**

Any provision of any prior ordinance of the City whether codified or uncodified, which are in conflict with any provision of this Ordinance, are hereby repealed to the extent of the conflict, but all other provisions of the ordinances of the City whether codified or uncodified, which are not in conflict with the provisions of this Ordinance, shall remain in full force and effect.

**SECTION 5.  
PENALTY CLAUSE**

Any person, firm, or corporation violating any of the provisions or terms of this Ordinance shall be guilty of a misdemeanor and upon conviction, shall be fined a sum not to exceed \$2,000.00 for each offense, and each and every violation or day such violation shall continue or exist, shall be deemed a separate offense.

**SECTION 6.  
PUBLICATION CLAUSE**

The City Secretary of the City is hereby directed to publish in the official newspaper of the City the caption, penalty clause, and effective date clause of this Ordinance as required by law.

**SECTION 7.  
EFFECTIVE DATE**

This Ordinance shall become effective immediately upon its passage and publication as required by law.

**PASSED, APPROVED AND ADOPTED** by the City Council of the City of Roanoke, Texas, on this June 23, 2026.

**APPROVED:**

\_\_\_\_\_  
Carl E. Gierisch, Jr., Mayor

**ATTEST:**

\_\_\_\_\_  
Lindsay Rawlinson, City Secretary

**APPROVED AS TO FORM:**

\_\_\_\_\_  
Jeff Moore, City Attorney

## Exhibit A

### Local Amendments to the *International Swimming Pool and Spa Code*

#### **Recommended Regional Amendments to the 2024 International Swimming Pool and Spa Code**

North Central Texas Council of Governments Region

The following sections, paragraphs, and sentences of the *2024 International Swimming Pool and Spa Code* are hereby amended as follows: Standard type is text from the ISPSC. Underlined type is text inserted. ~~Lined through type is deleted text from ISPSC.~~ A double asterisk at the beginning of a section identifies an amendment carried over from the 2021 edition of the code. A triple asterisk (\*\*\*) identifies a new or revised amendment with the 2024 ISPSC code.

#### **\*\*\*Section 102.9; Change to read as follows:**

**Section 102.9 Other laws.** The provisions of this code shall not be deemed to nullify any provisions of local, state or federal law, to include but not limited to:

1. Texas Department of State Health Services (TDSHS); *Standards for Public Pools and Spas*; §265.181 through §265.198, (TDSHS rules do not apply to pools serving one- and two-family dwellings or townhouses).
2. Texas Department of Licensing and Regulation (TDLR); *2012 Texas Accessibility Standards (TAS)*, TAS provide the scoping and technical requirements for accessibility for Swimming Pool, wading pools and spas and shall comply with *2012 TAS, Section 242*. (TAS rules do not apply to pools serving one- and two-family dwellings or townhouses).

**Exception:** Elements regulated under Texas Department of Licensing and Regulation (TDLR) and built in accordance with TDLR approved plans, including any variances or waivers granted by the TDLR, shall be deemed to be in compliance with the requirements of this Chapter.

*(Reason: To clarify specific Texas statutes which regulate public pools and spas.)*

#### **\*\*Section 113.4 Violation penalties; Changed to read as follows:**

**113.4 Violation penalties.** Any person who shall violate a provision of this code or shall fail to comply with any of the requirements thereof or who shall erect, install, alter or repair a pool or spa in violation of the *approved* construction documents or directive of the *code official*, or of a permit or certificate issued under the provisions of this code may be punishable for each day of the violation set forth by the authority having jurisdiction. ~~, shall be guilty of a [SPECIFY OFFENSE], punishable by a fine of not more than [AMOUNT] dollars or by imprisonment not exceeding [NUMBER OF DAYS], or both such a fine and imprisonment. Each day that a violation continues after due notice has been served shall be deemed a separate offense.~~

*(Reason: Covered by general provisions of the Code of Ordinances.)*



**\*\*Section 305; Change to read as follows:**

**305.1 General.**

The provisions of this section shall apply to the design of barriers for restricting entry into areas having pools and spas. In only one-and two-family dwellings and townhouses, where spas or hot tubs are equipped with a lockable safety cover complying with ASTM F1346 and swimming pools are equipped with a powered safety cover that complies with ASTM F1346, the areas where those spas, hot tubs or pools are located shall not be required to comply with Sections 305.2 through 305.7.

*(Reason: To clarify requirements for dwellings and commercial properties and specific Texas statutes which regulate public pools and spas.)*



**\*\* Add subsection 305.2.8.1; to read as follows:**

**305.2.8.1 Chain link fencing prohibited.** Chain link fencing is not permitted as a barrier in public pools built after January 1, 1994.

*(Reason: To clarify specific Texas Health and Safety Code Chapter 757.003 (f).)*



**\*\*Section 305.4 structure wall as a barrier; Changes as follows:**

**305.4 Structure wall as a barrier.** Where a wall of a dwelling or structure of a one- and two-family dwelling or townhouse or its accessory structure serves as part of a barrier and where doors or windows provide direct access to the pool or spa through that wall, one of the following shall be required:

- 1. Remainder Unchanged
- 2. Remainder Unchanged
- 3. Remainder Unchanged
- 4. Remainder unchanged
- 5. Remainder unchanged
- 6. Remainder unchanged

*(Reason: To clarify specific Texas Health and Safety Code Chapter 757.007.)*



**\*\*Section 305.6; Change to read as follows:**

**305.6 Natural barriers used in a one- and two-family dwelling or townhouse.** In the case where the pool or spa area abuts the edge of a lake or other natural body of water, public access is not permitted or allowed along the shoreline, and required barriers extend to and beyond the water's edge a minimum of eighteen (18) inches, a barrier is not required between the natural body of water shoreline and the pool or spa.

*(Reason: Specific Texas statutes do not allow the use of natural barriers in lieu of fencing for public pools per Chapter 757.003).*

**\*\*Section 307.1.5 Accessibility; Add exception to Section to 307.1.5 as follows:**

**Exception:** Components of projects regulated by and registered with Architectural Barriers Division of Texas Department of Licensing and Regulation shall be deemed to be in compliance with the requirements of this chapter.

*(Reason: To accommodate buildings regulated under state law. Further clarified to mean Components that are specifically addressed by TDLR shall be exempt.)*

**\*\*Section 307.2.2.2; add to read as follows:**

**Section 307.2.2.2. Adjacency to Structural Foundation.** Depth of the swimming pool and spa shall maintain a ratio of 1:1 from the nearest building foundation or footing of a retaining wall.

Exception:

A sealed engineered design drawing of the proposed new structure shall be submitted for approval.

*(Reason: To clarify specific distances for pools and spas, correlates with IRC 327.1.)*

**\*\*Section 310; Change to read as follows:**

**310.1 General.** Suction entrapment avoidance for pools and spas shall be provided in accordance with APSP 7 (ANSI/PHTA/ICC 7) or for public swimming pools in accordance with State of Texas Rules for Public Swimming Pools and Spas, Title 25 TAC Chapter 265 Subchapter L, Rule §265.190.

*[Remainder unchanged]*

*(Reason: To clarify specific Texas statutes which regulate public pools and spas.)*

**\*\* Section 402.12; Change to read as follows:**

**402.12 Water envelopes.** The minimum diving water envelopes shall be in accordance with ~~Table 402.12~~ Texas department of State Health services, Administrative Code Title 25, Chapter 265, Section 186 (e) and Figure: 25 TAC 256.186 (e) (6). (Delete Table 402.12 and Figure 402.12)

ADD: Figure: 25 TAC §265.186 (e) (6)

Maximum Diving Board Height Over Water	¾ Meter	1 Meter	3 Meters
Max. Diving Board Length	12 ft.	16 ft.	16 ft.
Minimum Diving Board Overhang	2 ft. 6 in.	5 ft.	5 ft.
D1 Minimum	8 ft. 6 in.	11 ft. 2 in.	12 ft. 2 in.
D2 Minimum	9 ft.	10 ft. 10 in.	11 ft. 10 in.
D3 Minimum	4 ft.	6 ft.	6 ft.
L1 Minimum	4 ft.	5 ft.	5 ft.
L2 Minimum	12 ft.	16 ft. 5 in.	19 ft. 9 in.
L3 Minimum	14 ft. 10 in.	13 ft. 2 in.	13 ft. 11 in.
L4 Minimum	30 ft. 10 in.	34 ft. 7 in.	38 ft. 8 in.
L5 Minimum	8 ft.	10 ft.	13 ft.
H Minimum	16 ft.	16 ft.	16 ft.
From Plummet to Pool Wall at Side	9 ft.	10 ft.	11 ft. 6 in.
From Plummet to Adjacent Plummet	10 ft.	10 ft.	10 ft.

H (Overhead Obstruction or Ceiling)

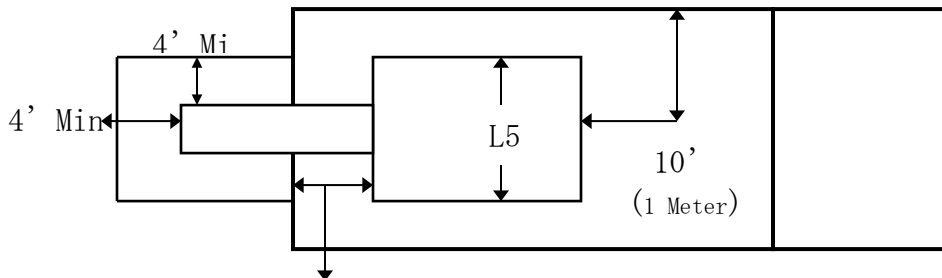
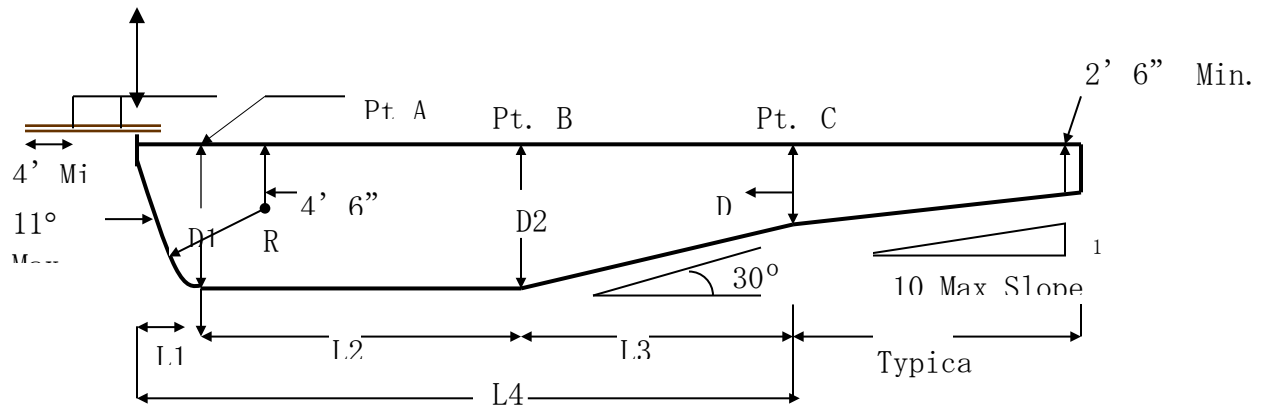

(Reason: To be consistent with state requirements.)

**\*\*Section 411.2.1 & 411.2.2; Change to read as follows:**

**411.2.1 Tread dimensions and area.** Treads shall have a minimum unobstructed horizontal depth (i.e., horizontal run) of 12 inches and a minimum width of 20 inches. not be less than 24 inches (607mm) at the leading edge. ~~Treads shall have an unobstructed surface area of not less than 240 square inches (154838mm<sup>2</sup>) and an unobstructed horizontal depth of not less than 10 inches (254 mm) at the center line.~~

**411.2.2 Risers.** Risers for steps shall have a maximum uniform height of 10 inches, with the bottom riser height allowed to taper to zero except for the bottom riser, shall have a uniform height of not greater than 12 inches (305 mm) measured at the center line. ~~The bottom riser height is allowed to vary to the floor.~~

*(Reason: To avoid conflict with state requirements.)*

**\*\*Section 411.5.1 & 411.5.2; Change to read as follows:**

**411.5.1 Swimouts.** Swimouts, located in either the deep or shallow area of a pool, shall comply with all of the following:

1. Unchanged
2. Unchanged
3. Unchanged
4. The leading edge shall be visibly set apart and provided with a horizontal solid or broken stripe at least 1 inch wide on the top surface along the front leading edge of each step. This stripe shall be plainly visible to persons on the pool deck. The stripe shall be a contrasting color to the background on which it is applied, and the color shall be permanent in nature and shall be a slip-resistant surface.

**411.5.2 Underwater seats and benches.** Underwater seats and benches, whether used alone or in conjunction with pool stairs, shall comply with all of the following:

1. Unchanged
2. Unchanged
3. Unchanged
4. Unchanged
5. The leading edge shall be visually set apart and provided with a horizontal solid or broken stripe at least 1 inch wide on the top surface along the front leading edge of each step. This stripe shall be plainly visible to persons on the pool deck. The stripe shall be a contrasting color to the background on which it is applied, and the color shall be permanent in nature and shall be a slip-resistant surface.
6. Unchanged
7. Unchanged

*(Reason: To be consistent with state requirements.)*

**\*\*Section 610.5.1; Change to read:**

**610.5.1 Uniform height of 9–10 inches.** Except for the bottom riser, risers at the centerline shall have a maximum uniform height of 9–10 inches (229–254 mm). The bottom riser height shall be permitted to vary from the other risers.

*(Reason: To be consistent with state requirements.)*

**\*\*Section 804 Diving Water Envelopes; Change to read as follows:**

**Section 804.1 General.** The minimum diving water envelopes shall be in accordance with Table 804.1 and Figure 804.1, or the manufacturer's specifications, whichever is greater. Negative construction tolerances shall not be applied to the dimensions of the minimum diving water envelopes given in Table 804.1.

*(Reason: To provide minimum standards and to clarify specific manufactures specifications of the diving equipment.)*

**END**



## AGENDA ITEM

TO: Mayor and City Council

SUBJECT: 2024 edition of the National Electrical Code

MEETING DATE: June 23, 2026

DEPARTMENT: Planning

---

### **ITEM SUMMARY:**

Consideration and action on approval of Ordinance No. 2026-135, approving the 2024 edition of the National Electrical Code and local amendments thereto.

### **INFORMATION:**

North Central Texas Council of Governments - Regional Codes Coordinating Committee and its five advisory boards conducted multiple meetings to review the latest editions of the model codes and develop regional amendments. Their review and recommendations are endorsed by NCTCOG's Executive Board. NCTCOG encourages jurisdictions in North Central Texas to adopt the following model construction codes along with their respective regional amendments as expeditiously as their local code adoption process will allow.

NCTCOG issued a memorandum to jurisdictions in North Central Texas to adopt the code updates on May 1, 2025.

### **STAFF RECOMMENDATION:**

Staff recommends approval.

### **SPECIAL CONSIDERATION:**

### **FINANCIAL CONSIDERATION:**

ATTACHMENTS:



## AGENDA ITEM

1. Ordinance No. 2026-135 - National Electrical Code - 2026 Edition - with local amendments

**ORDINANCE NO. 2026-135**

**AN ORDINANCE OF THE CITY COUNCIL OF THE CITY OF ROANOKE, TEXAS, AMENDING CHAPTER 3, ARTICLE 3.100 OF THE CODE OF ORDINANCES OF THE CITY OF ROANOKE, TEXAS, ENTITLED “INTERNATIONAL CODES ADOPTED” BY REPEALING IN ITS ENTIRETY SECTION 3.102 ENTITLED “NATIONAL ELECTRICAL CODE ADOPTED,” AND REPLACING IT WITH A NEW SECTION 3.102 ENTITLED “NATIONAL ELECTRICAL CODE ADOPTED,” BY ADOPTING THE 2026 EDITION OF THE *NATIONAL ELECTRICAL CODE*, AND LOCAL AMENDMENTS TO THE *NATIONAL ELECTRICAL CODE*; PROVIDING A SEVERABILITY CLAUSE; PROVIDING A REPEALER CLAUSE; PROVIDING A PENALTY FOR VIOLATIONS; PROVIDING FOR PUBLICATION IN THE OFFICIAL NEWSPAPER; AND PROVIDING FOR AN EFFECTIVE DATE.**

**WHEREAS**, the City Council of the City of Roanoke, Texas, is of the opinion that the 2026 Edition of the *National Electrical Code*, along with local amendments hereto, should be adopted as the National Electrical Code for the City of Roanoke.

**NOW, THEREFORE, BE IT ORDAINED BY THE CITY COUNCIL OF THE CITY OF ROANOKE, TEXAS, THAT:**

**SECTION 1.  
FINDINGS INCORPORATED**

The findings set forth above are incorporated into the body of this Ordinance as if fully set forth herein.

**SECTION 2.  
AMENDMENT**

Chapter 3, Article 3.100, of the Code of Ordinances of the City of Roanoke, Texas, entitled “International Codes Adopted,” is hereby amended by repealing in its entirety Section 3.102 entitled “National Electrical Code Adopted” and replacing it with a new Section 3.102 entitled “National Electrical Code Adopted,” which shall read as follows:

**“Sec. 3.102. National Electrical Code Adopted.**

(a) *Adoption.* The *National Electrical Code*, 2026 edition, is hereby adopted and designated as the National Electrical Code for the City of Roanoke, Texas. A copy of the 2026 Edition of the *National Electrical Code* is on file in the office of the city secretary.

(b) *Local Amendments.* The following provisions, attached hereto as **Exhibit A** of this Ordinance, are local amendments to the 2026 Edition of the *National*

*Electrical Code*. Each provision in this subsection is a substitute for the identically numbered provision contained in the 2026 Edition of the *National Electrical Code* or is an additional provision added to the 2026 Edition of the *National Electrical Code*.

**SECTION 3.  
SEVERABILITY CLAUSE**

It is hereby declared to be the intention of the City Council that the phrases, clauses, sentences, paragraphs and sections of this Ordinance are severable, and if any phrase, clause, sentence, paragraph or section of this Ordinance shall be declared unconstitutional by the valid judgment or decree of any court of competent jurisdiction, such unconstitutionality shall not affect any of the remaining phrases, clauses, sentences, paragraphs and sections of this Ordinance, since the same would have been enacted by the City Council without the incorporation of this Ordinance of any such unconstitutional phrase, clause, sentence, paragraph or section.

**SECTION 4.  
REPEALER CLAUSE**

Any provision of any prior ordinance of the City whether codified or uncoded, which are in conflict with any provision of this Ordinance, are hereby repealed to the extent of the conflict, but all other provisions of the ordinances of the City whether codified or uncoded, which are not in conflict with the provisions of this Ordinance, shall remain in full force and effect.

**SECTION 5.  
PENALTY CLAUSE**

Any person, firm, or corporation violating any of the provisions or terms of this Ordinance shall be guilty of a misdemeanor and upon conviction, shall be fined a sum not to exceed \$2,000.00 for each offense, and each and every violation or day such violation shall continue or exist, shall be deemed a separate offense.

**SECTION 6.  
PUBLICATION CLAUSE**

The City Secretary of the City is hereby directed to publish in the official newspaper of the City the caption, penalty clause, and effective date clause of this Ordinance as required by law.

**SECTION 7.  
EFFECTIVE DATE**

This Ordinance shall become effective immediately upon its passage and publication as required by law.

**PASSED, APPROVED AND ADOPTED** by the City Council of the City of Roanoke, Texas, on this June 23, 2026.

**APPROVED:**

\_\_\_\_\_  
Carl E. Gierisch, Jr., Mayor

**ATTEST:**

\_\_\_\_\_  
Lindsay Rawlinson, City Secretary

**APPROVED AS TO FORM:**

\_\_\_\_\_  
Jeff Moore, City Attorney

## Exhibit A

### Local Amendments to the *National Electrical Code*

#### Recommended Amendments to the 2026 National Electrical Code North Central Texas Council of Governments

The following articles, paragraphs, and sentences of the *2026 National Electrical Code (NEC)* are hereby amended as follows: Standard type is text from the NEC. Underlined type is text inserted. ~~Lined through type is deleted text from NEC.~~ A double asterisk (\*\*) at the beginning of an article identifies an amendment carried over from the 2023 edition of the code and a triple asterisk (\*\*\*) identifies a new or revised amendment with the 2026 code.

**\*\*\*Article 100; add the following to definitions:**

**Engineering Supervision.** Supervision by a Qualified State of Texas Licensed Professional Engineer engaged primarily in the design or maintenance of electrical installations as referenced by 22 Texas Administrative Code Sections 137.59 (a) and (b) as acceptable by the AHJ.

*(REASON FOR CHANGE: To better define the qualifications for engineering supervision. This term is used 169 times in the 2026 National Electrical Code.)*

**\*\*\*Article 110.2; change to read as follows:**

**110.2 Approval.** The conductors and equipment required or permitted by this Code shall be acceptable only if approved. Approval of equipment may be evident by listing and labeling of equipment by a Nationally Recognized Testing Laboratory (NRTL) with a certification mark of that laboratory or a qualified third-party inspection agency or a field evaluation by a field evaluation body accredited by either the International Code Council, International Accreditation Service AC354 or ANSI National Accreditation Board programs and approved by the AHJ.

*Exception: Unlisted equipment that is relocated to another location within a jurisdiction or is field modified is subject to the approval by the AHJ. This approval may be by a field evaluation by a NRTL or qualified third-party inspection agency or a field evaluation by a Field Evaluation Body accredited by either the ICC IAS AC354 or ANAB programs and approved by the AHJ.*

*Informational Note No. 1: See 90.7, Examination of Equipment for Safety, and 110.3, Examination, Identification, Installation, Use, and listing (Product Certification) of Equipment.*

*Informational Note No. 2: See Article 100 for the definition of Approved, Identified, Labeled, and Listed.*

Informational Note No. 3: Manufacturer's self-certification of equipment may not necessarily comply with U.S. product safety standards as certified by an NRTL.

Informational Note No. 4: National Fire Protection Association (NFPA) 790 and 791 provide an example of an approved method for qualifying a third-party inspection agency.

(REASON FOR CHANGE: To add clarity and provide more positive options for enforcement and approval of unlisted equipment.)

**\*\*\*Article 110.12; change to read as follows:**

**110.12 Mechanical Execution of Work.** The installation and servicing of electrical equipment and all associated wiring shall be installed performed by qualified persons in a professional and skillful manner.

(REASON FOR CHANGE: To add clarity and provide more positive options for enforcement.)

**\*\*\*Article 110.12(B); add the following to:**

**(B) Integrity of Electrical Equipment and Connections.** Internal parts of electrical equipment, including busbars, wiring terminals, insulators, and other surfaces, shall not be damaged or contaminated by foreign materials such as paint, plaster, cleaners, abrasives, corrosive residues or influences, fire, products of combustion, or water. There shall be no damaged parts that may adversely affect safe operation or mechanical strength of the equipment such as parts that are broken; bent; cut; or deteriorated by corrosion, chemical action, or overheating. Except where prohibited elsewhere in this Code, equipment shall be specifically evaluated by its manufacturer or a qualified testing laboratory prior to being returned to service.

Informational Note No. 1: See NEMA GD 1-2019, Evaluating Water-Damaged Electrical Equipment, for information on electrical equipment and wiring methods damaged by water.

Informational Note No. 2: See NEMA GD 2-2021, Evaluating Fire- and Heat-Damaged Electrical Equipment, for information on electrical equipment and wiring methods damaged by fire or heat.

(REASON FOR CHANGE: To better define a Plan of Action for equipment that is compromised prior to restoring to service)

**\*\*\*110.26(C)(1); change the following to read as follows:**

**(1) Minimum Required.** At least one entrance of sufficient area shall be provided to give access to and egress from working space about electrical equipment. The pathway shall be continuous and unobstructed from the required working space for a minimum of 7.6 m (25 ft).

*(REASON FOR CHANGE: To add clarity and provide more positive options for enforcement)*

**\*\*\*Article 120.8; add the following:**

**120.8 Load Calculation.** A load calculation shall be provided to the AHJ upon request when modifications to the electrical installation occurs.

*(REASON FOR CHANGE: To provide a positive option to verify compliance with this code.)*

**\*\*Article 210.52(C)(1) Exception; change to read as follows:**

**(C) Countertops and Work Surfaces.** In kitchens, pantries, breakfast rooms, dining rooms, and similar areas of dwelling units, receptacle outlets for countertop and work surfaces that are 300 mm (12 in.) or wider shall be installed in accordance with 210.52(C)(1) with through (C)(3) and shall not be considered as the receptacle outlets required by **210.52(A)**.

For the purposes of this section, where using multioutlet assemblies, each 300 mm (12 in.) of multioutlet assembly containing two or more receptacles installed in individual or continuous lengths shall be considered to be one receptacle outlet.

**(1) Wall Spaces.** Receptacle outlets shall be installed so that no point along the wall line is more than 600 mm (24 in.) measured horizontally from a receptacle outlet in that space. The location of the receptacles shall be in accordance with 210.52(C)(3).

*Exception No. 1: Receptacle outlets shall not be required directly behind a range, counter-mounted cooking unit, or sink in the installation described in Figure 210.52(C)(1).*

~~*Exception No. 2: Where a required receptacle outlet cannot be installed in the wall areas shown in Figure 210.52(C)(1), the receptacle outlet shall be permitted to be installed as close as practicable to the countertop area to be served. The total number of receptacle outlets serving the countertop shall not be less than the number needed to satisfy 210.52(C)(1). These outlets shall be located in accordance with 210.52(C)(3).*~~

*(REASON FOR CHANGE: Elimination of receptacles in an area with a concept window wall configuration over the countertop is not the only option as there are devices available for a compliant installation)*

**\*\*\*Article 210.52(C)(2): change to read as follows:**

**(2) Island and Peninsular Countertops and Work Surfaces.** If provided to serve an island or peninsular countertop or work surface, receptacle outlets shall be installed in accordance with 210.52(C)(3) and 210.52(C)(4). If a receptacle outlet is not provided to serve an island or peninsular countertop or work surface, a small appliance branch circuit in an approved wiring method shall be installed to a listed outlet box in the peninsular or island cabinet at an accessible location ~~electrical provisions shall be provided at the island or peninsula~~ for future addition of a receptacle outlet to serve the island or peninsular countertop or work surface.

*(REASON FOR CHANGE: To clarify what the provisions are for positive options for enforcement and approval)*

**\*\*\*Article 230.70(E) Exception; change to read as follows:**

*Exception: If existing service equipment, installed in compliance with previous editions of this Code, and only meter sockets, service entrance conductors, or related raceways and fittings are replaced, the requirements of 230.70(A)(1) and 230.70(A)(2) shall not apply.*

*(REASON FOR CHANGE: The language that exists was amended in the 2023 NEC. It was moved to its new section in the 2026 NEC.)*

**\*\*\*Article 250.50; change to read as follows:**

**Grounding Electrode System.** All grounding electrodes as described in 250.52(A)(1) through 250.52(A)(7) that are present at each building or structure served shall be bonded together to form the grounding electrode system. If none of these grounding electrodes exist, one or more of the grounding electrodes specified in 250.52(A)(4) through 250.52(A)(8) shall be installed and used. If the concrete encased electrode as required by 250.52(A)(3) is covered during construction prior to an inspection, one of the following shall be required:

- (1) A ground ring installed in accordance with 250.52(A)(4).
- (2) Under engineering supervision, a point of connection to the concrete encased electrode shall be detailed.

*(REASON FOR CHANGE: To provide uniform enforcement across North Texas for the ease of the contractor in the event an electrode is covered.)*

**\*\*Article 408.4; change to read as follows:**

**(A) Circuit Directory or Circuit Description.** Every circuit and circuit modification shall be provided with a legible and permanent description that complies with all of the following conditions as applicable:

- (1) Located at each switch or circuit breaker in a switchboard or switchgear
- (2) Included in a circuit directory that is located on the face of, inside of, or in an approved location and permanently affixed to the panel door in the case of a panelboard
- (3) Clear, evident, and specific to the purpose or use of each circuit including spare positions with an unused overcurrent device
- (4) Described with a degree of detail and clarity that is unlikely to result in confusion between circuits
- (5) Not dependent on transient conditions of occupancy
- (6) Clear in explaining abbreviations and symbols when used

*(REASON FOR CHANGE: To add clarity and provide more positive options for enforcement and approval)*

**\*\*Article 410.118; change to read as follows:**

**410.118 Access to other boxes.** Luminaires recessed in the ceilings, floors, or walls shall not be used to access outlet, pull, or junction boxes or conduit bodies, unless the box or conduit body is an integral part of the listed luminaire.

*Exception: removable luminaires with a minimum measurement of 22 in. X 22 in. shall be permitted to be used as access to outlet, pull, junction boxes or conduit bodies.*

*(REASON FOR CHANGE: To add clarity and provide more positive options for enforcement and approval. This will allow access to boxes not integral with the luminaire. This measurement aligns with the limited access above a lay-in ceiling measurement in 110.26(A)(4).*

**\*\*Article 422.31(B); change to read as follows**

~~**(B) Appliances Rated Over 300 Volt-Amperes.** For permanently connected appliances rated over 300 volt-amperes, the branch-circuit switch or circuit breaker shall be permitted to serve as the disconnecting means where the switch or circuit breaker is within sight from and is readily accessible to the appliance it serves or is capable of being locked in the open position in accordance with 110.25 and is readily accessible to the appliance it serves.~~

~~Informational Note No. 1: For appliances employing unit switches, see 422.34.~~

Informational Note No. 2: The following means of access are considered to constitute readily accessible for this code change when conforming to the additional access requirement of the I-Codes:

(1) A permanent stair.

(2) A pull-down stair with a minimum 300 lb. (136kg) capacity.

(3) An access door from an upper floor level.

*(REASON FOR CHANGE: The language of this article was revised in the 2026 NEC. Enforcement of its requirements may be handled through other sections. It can be deleted.)*

**\*\*\*Article 500.8(A)(3); change to read as follows:**

**(A) Suitability.** Suitability of identified equipment tested and investigated for use as defined in this article shall be determined by one of the following:

(1) Equipment listing or labeling

(2) Evidence of equipment evaluation from a qualified laboratory or inspection agency concerned with product evaluation

~~(3) Evidence acceptable to the authority having jurisdiction such as a manufacturer's self-evaluation~~

*(REASON FOR CHANGE: Recommend for added clarity and to provide more positive options for enforcement.)*

**\*\*\*Article 505.7 (A); change to read as follows:**

**(A) Implementation of Zone Classification System.** Classification of areas, engineering and design, selection of equipment and wiring methods, and an onsite assessment of the installation, and inspection shall be performed by qualified licensed professional engineer in the State of Texas engaged primarily in the design or maintenance of electrical installations as referenced in 22 Texas Administrative Code Sections 137.59(a) and (b) as acceptable by the AHJ persons.

*(REASON FOR CHANGE: Recommend for added clarity, positive enforcement options, and legal corrections.)*

**\*\*\*Article 600.4(B); change to read as follows:**

**(B) Visibility.** Listing labels and markings that identify the input voltage and current rating shall be visible after installation and be permanently applied in a location visible prior to servicing. The marking shall be permitted in a location not viewed by the public.

A Class 2 field wired sign shall have the listing label permanently applied on the power supply enclosure.

*(REASON FOR CHANGE: To provide a positive option to verify compliance with this code and UL 48, Standard for Electric Signs.)*

**\*\*\*Article 695.7(A)(1); change to read as follows:**

**(1) Services and On-Site Power Production Facilities.** Service conductors and conductors supplied by on-site power production facilities shall be physically routed outside a building(s) and shall be installed as service-entrance conductors in accordance with 230.9 and Article 230 Parts III and IV. Where supply conductors cannot be physically routed outside of buildings, the conductors shall be permitted to be routed through the building(s) where installed in accordance with 695.7(A)(2)(d)(1) or 695.7(A)(2)(d)(2).

*Exception: The supply conductors within the fire pump room shall not be required to meet 695.7(A)(2)(d)(2).*

*(REASON FOR CHANGE: To add clarity and provide more positive options for enforcement and approval. All Fire Pump rooms are not Fire Rated as on all 4 sides. There are Fault Currents that could exceed 150,000-190,000 amps and protection of these Service Conductors is essential and conflict with other codes, specifically 230.70(A)(1).)*

**\*\*\*Article 700.4(A); change to read as follows:**

**(A) Commissioning Witness Test.** The authority having jurisdiction shall conduct or witness the commissioning in person, remotely or through documentation acceptable to the AHJ of the completed system upon installation and periodically afterward.

*(REASON FOR CHANGE: To add additional paths for compliance that will ease scheduling on the contractor and field inspection staff.)*

**\*\*\*Article 701.4(A); change to read as follows:**

**(A) Commissioning Witness Test.** The authority having jurisdiction shall conduct or witness the commissioning in person, remotely or through documentation acceptable to the AHJ of the completed system upon installation.

*(REASON FOR CHANGE: To add additional paths for compliance that will ease scheduling on the contractor and field inspection staff.)*

**\*\*Article 705.8; change to read as follows:**

**705.8 System Installation.** Installation of one or more electrical power production sources operating in parallel with a primary source(s) of electricity shall be performed only by qualified persons. During the installation there shall be on site one of the following:

(1) A person holding a Master Electrician License issued by the Texas Department of Licensing and Regulation.

(2) A person holding a Journeyman Electrician License issued by the Texas Department of Licensing and Regulation.

*(REASON FOR CHANGE: These are specialized systems as evidenced by the Code, which contain installation requirements from chapter 6, Specific Equipment and chapter 7 Specific Conditions.)*

**\*\*\*Article 705.11(C)(1); change to read as follows:**

**Power Source Connections in Buildings.** Power source service conductors located within buildings and connected to existing service conductors or equipment shall be terminated in a disconnect located in accordance with 230.70(A)(1) and protected in accordance with 230.91. ~~one of the following methods:~~

~~(1) In dwelling units, with an OCPD located within 3 m (10 ft) of conductor length from the point of connection~~

~~(2) In other than dwelling units, with an OCPD located within 5 m (16.5 ft) of conductor length from the point of connection~~

~~(3) Under engineering supervision for services not over 1000 volts ac, nominal, in other than dwelling units in accordance with the following:~~

~~(a) With one cable limiter per ungrounded conductor, located within switchgear or similar enclosures, and within 5 m (16.5) of conductor length from the point of connection~~

~~(b) With an OCPD located within 20 m (66 ft) of conductor length from the point of connection~~

*(REASON FOR CHANGE: Code language as written creates a life safety hazard.)*

**\*\*Article 705.80; change to read as follows:**

**705.80 Power Source Capacity.** For interconnected power production sources that operate in island mode, capacity shall be calculated using the sum of all power source output maximum currents for the connected power production source. Solar photovoltaic (PV) and wind systems shall not be included in the sum capacity.

*(REASON FOR CHANGE: To keep unreliable production sources out of the calculation as 705 creates conflicts with all standby systems.)*

**\*\*\*Article 706.7(A); change to read as follows:**

**(A) Commissioning.** ESS's shall be commissioned upon installation in accordance with manufacturer's instructions. The commissioning report, which shall include the operational controls and safety systems, shall be provided upon request of the AHJ. Unless required elsewhere in this code, the AHJ shall not be required to conduct or witness the commissioning of the ESS.

*(REASON FOR CHANGE: To add additional paths for compliance that will ease scheduling on the contractor and field inspection staff.)*

**\*\*\*Article 706.15(B); change to read as follows:**

**(B) Location and Control.** The disconnecting means shall be readily accessible and comply with one or more of the following:

(1) Be located within the ESS

(2) Be located and visible and within 3 m (10 ft) from the ESS

*Informational Note: See Article 100 and 90.4(C) for information on special permission*

(3) Be lockable open in accordance with 110.25, or the enclosure providing access to the disconnecting means be capable of being locked closed.

Where controls to activate the disconnecting means of an ESS are used and are not located within sight of the ESS, the disconnecting means shall be lockable in accordance with 110.25, and the location of the controls shall be marked on the disconnecting means.

Where the equipment contains a door assembly, the disconnecting means shall be located outside and within sight of the ESS.

For one- and two-family dwellings, an ESS shall include an emergency shutdown function to cease the export of power from the ESS to premises wiring of other systems. An initiation device(s) shall be located at a readily accessible location outside the building and shall plainly indicate whether in the "off" or "on" position. The "off" position of the device(s) shall perform the ESS emergency shutdown function.

*(REASON FOR CHANGE: To provide an appropriate level of protection for pre-assembled walk in ESS units. These systems have led to serious injury when entering by first responders.)*

**\*\*\*Article 708.6; change to read as follows:**

**Conduct or Witness Test.** The authority having jurisdiction shall conduct or witness a test in person, remotely or through documentation acceptable to the AHJ of the completed system upon installation and periodically afterward.

*(REASON FOR CHANGE: To add additional paths for compliance that will ease scheduling on the contractor and field inspection staff.)*

**END**



## AGENDA ITEM

TO: Mayor and City Council

SUBJECT: 2024 edition of the International Building Code

MEETING DATE: June 23, 2026

DEPARTMENT: Planning

---

### ITEM SUMMARY:

Consideration and action on approval of Ordinance No. 2026-136, approving the 2024 edition of the International Building Code and local amendments thereto.

### INFORMATION:

North Central Texas Council of Governments - Regional Codes Coordinating Committee and its five advisory boards conducted multiple meetings to review the latest editions of the model codes and develop regional amendments. Their review and recommendations are endorsed by NCTCOG's Executive Board. NCTCOG encourages jurisdictions in North Central Texas to adopt the following model construction codes along with their respective regional amendments as expeditiously as their local code adoption process will allow.

NCTCOG issued a memorandum to jurisdictions in North Central Texas to adopt the code updates on May 1, 2025.

### STAFF RECOMMENDATION:

Staff recommends approval.

### SPECIAL CONSIDERATION:

### FINANCIAL CONSIDERATION:

ATTACHMENTS:



## AGENDA ITEM

1. Ordinance No. 2026-136 - International Building Code - 2024 Edition - with local amendments

**ORDINANCE NO. 2026-136**

**AN ORDINANCE OF THE CITY COUNCIL OF THE CITY OF ROANOKE, TEXAS, AMENDING CHAPTER 3, ARTICLE 3.100 OF THE CODE OF ORDINANCES OF THE CITY OF ROANOKE, TEXAS, ENTITLED “INTERNATIONAL CODES ADOPTED” BY REPEALING IN ITS ENTIRETY SECTION 3.101 ENTITLED “INTERNATIONAL BUILDING CODE ADOPTED,” AND REPLACING IT WITH A NEW SECTION 3.101 ENTITLED “INTERNATIONAL BUILDING CODE ADOPTED,” BY ADOPTING THE 2024 EDITION OF THE *INTERNATIONAL BUILDING CODE*, AND LOCAL AMENDMENTS TO THE *INTERNATIONAL BUILDING CODE*; PROVIDING A SEVERABILITY CLAUSE; PROVIDING A REPEALER CLAUSE; PROVIDING A PENALTY FOR VIOLATIONS; PROVIDING FOR PUBLICATION IN THE OFFICIAL NEWSPAPER; AND PROVIDING FOR AN EFFECTIVE DATE.**

**WHEREAS**, the City Council of the City of Roanoke, Texas, is of the opinion that the 2024 Edition of the *International Building Code*, along with local amendments hereto, should be adopted as the Building Code for the City of Roanoke.

**NOW, THEREFORE, BE IT ORDAINED BY THE CITY COUNCIL OF THE CITY OF ROANOKE, TEXAS, THAT:**

**SECTION 1.  
FINDINGS INCORPORATED**

The findings set forth above are incorporated into the body of this Ordinance as if fully set forth herein.

**SECTION 2.  
AMENDMENT**

Chapter 3, Article 3.100, of the Code of Ordinances of the City of Roanoke, Texas, entitled “International Codes Adopted,” is hereby amended by repealing in its entirety Section 3.101 entitled “International Building Code Adopted” and replacing it with a new Section 3.101 entitled “International Building Code Adopted,” which shall read as follows:

**“Sec. 3.101. International Building Code Adopted.**

- (a) *Adoption.* The *International Building Code*, 2024 edition, is hereby adopted and designated as the Building Code for the City of Roanoke, Texas. A copy of the 2024 Edition of the *International Building Code* is on file in the office of the city secretary.
- (b) *Local Amendments.* The following provisions, attached hereto as **Exhibit A** of this Ordinance, are local amendments to the 2024 Edition of the *International Building*

*Code*. Each provision in this subsection is a substitute for the identically numbered provision contained in the 2024 Edition of the *International Building Code* or is an additional provision added to the 2024 Edition of the *International Building Code*.

### **SECTION 3. SEVERABILITY CLAUSE**

It is hereby declared to be the intention of the City Council that the phrases, clauses, sentences, paragraphs and sections of this Ordinance are severable, and if any phrase, clause, sentence, paragraph or section of this Ordinance shall be declared unconstitutional by the valid judgment or decree of any court of competent jurisdiction, such unconstitutionality shall not affect any of the remaining phrases, clauses, sentences, paragraphs and sections of this Ordinance, since the same would have been enacted by the City Council without the incorporation of this Ordinance of any such unconstitutional phrase, clause, sentence, paragraph or section.

### **SECTION 4. REPEALER CLAUSE**

Any provision of any prior ordinance of the City whether codified or uncodified, which are in conflict with any provision of this Ordinance, are hereby repealed to the extent of the conflict, but all other provisions of the ordinances of the City whether codified or uncodified, which are not in conflict with the provisions of this Ordinance, shall remain in full force and effect.

### **SECTION 5. PENALTY CLAUSE**

Any person, firm, or corporation violating any of the provisions or terms of this Ordinance shall be guilty of a misdemeanor and upon conviction, shall be fined a sum not to exceed \$2,000.00 for each offense, and each and every violation or day such violation shall continue or exist, shall be deemed a separate offense.

### **SECTION 6. PUBLICATION CLAUSE**

The City Secretary of the City is hereby directed to publish in the official newspaper of the City the caption, penalty clause, and effective date clause of this Ordinance as required by law.

### **SECTION 7. EFFECTIVE DATE**

This Ordinance shall become effective immediately upon its passage and publication as required by law.

**PASSED, APPROVED AND ADOPTED** by the City Council of the City of Roanoke, Texas, on this June 23, 2026.

**APPROVED:**

\_\_\_\_\_  
Carl E. Gierisch, Jr., Mayor

**ATTEST:**

\_\_\_\_\_  
Lindsay Rawlinson, City Secretary

**APPROVED AS TO FORM:**

\_\_\_\_\_  
Jeff Moore, City Attorney

**Exhibit A**  
Local Amendments to the *International Building Code*

**Recommended Amendments to the 2024 International Building Code**  
North Central Texas Council of Governments Region

The following sections, paragraphs, and sentences of the *2024 International Building Code* are hereby amended as follows: Standard type is text from the IBC. Underlined type is text inserted. ~~Lined through type is deleted text from IBC.~~ A double asterisk (\*\*) at the beginning of a section identifies an amendment carried over from the 2021 edition of the code and a triple asterisk (\*\*\*) identifies a new or revised amendment with the 2024 code.

Explanation of Options A and B:

Please note that as there is a wide range in firefighting philosophies / capabilities of cities across the region, OPTION "A" and OPTION "B" are provided in the Fire and Building Code amendments. Jurisdictions should choose one or the other based on their firefighting philosophies/capabilities when adopting code amendments.

**\*\*Section 101.4; change to read as follows:**

**101.4 Referenced codes.** The other codes listed in Sections 101.4.1 through 101.4.8 and referenced elsewhere in this code, when specifically adopted, shall be considered part of the requirements of this code to the prescribed extent of each such reference. Whenever amendments have been adopted to the referenced codes and standards, each reference to said code and standard shall be considered to reference the amendments as well. Any reference to NFPA 70 or the Electrical Code shall mean the Electrical Code as adopted.

*(Reason: Legal wording to recognize locally adopted codes and amendments adopted with referenced codes.)*

**\*\*Section 101.4.8; add the following:**

**101.4.8 Electrical.** The provisions of the local adopted Electrical Code shall apply to the installation of electrical systems, including alterations, repairs, replacement, equipment, appliances, fixtures, fittings and appurtenances thereto.

*(Reason: This was dropped when ICC quit publishing the ICC Electrical Code, but the Electrical Code still should be referenced regardless of how it is adopted.)*

**\*\*Sections 103.1; amend to insert the Department Name**

**103.1 Creation of enforcement agency.** The [INSERT NAME OF DEPARTMENT] is hereby created and the official in charge thereof shall be known as the *building official*.

[Remainder Unchanged]

*(Reason: Reminder to be sure ordinance reads the same as designated by the city and amend Section 101.1.)*

**\*\*Section 104.2.4.1; Flood hazard areas.** *(Jurisdictions may consider the option to amend or delete depending on local enforcement and flood hazard ordinances.)*

*(Reason: Flood hazard ordinances may be administered by other departments within the city.)*

*(Note: Sections 104.2.4.1, 104.3.1, 110.3.12.1, 1612, and 1603.1.7 are all interconnected related to flood hazard areas, and amendments or deletions should be considered as a whole.)*

**\*\*Section [A] 104.3.1 Determination of substantially improved or substantially damaged existing buildings and structures in flood hazard areas.** *(Jurisdictions may consider the option to amend or delete depending on local enforcement and flood hazard ordinances.)*

*(Reason: Flood hazard ordinances may be administered by other departments within the city.)*

**\*\*Section 105.2 Work exempt from permit; under sub-title entitled "Building" delete items 1, 2, 10 and 11 and re-number as follows:**

**Building:**

- ~~1. One-story detached accessory structures used as tool and storage sheds, playhouses and similar uses, provided the floor area does not exceed 120 square feet (11 m<sup>2</sup>).~~
- ~~2. Fences not over 7 feet (1829 mm) high.~~
- ~~3. 1. (Remainder Unchanged)~~
- ~~4. 2. (Remainder Unchanged)~~
- ~~5. 3. (Remainder Unchanged)~~
- ~~6. 4. (Remainder Unchanged)~~
- ~~7. 5. (Remainder Unchanged)~~
- ~~8. 6. (Remainder Unchanged)~~
- ~~9. 7. (Remainder Unchanged)~~
- ~~10. Shade cloth structures constructed for nursery or agricultural purposes, not including service systems.~~
- ~~11. 8. (Remainder Unchanged)~~
- ~~12. 9. (Remainder Unchanged)~~
- ~~13. 10. (Remainder Unchanged)~~

*(Reason: Items deleted are for one- and two-family dwellings regulated by the International Residential Code. Accessory structures, fences and shade cloth structures would require a permit for commercial properties to ensure compliance with local ordinance, egress, accessibility, flame spread of fabric, wind/snow design load, etc.)*

**\*\*Section 109; add Section 109.7 to read as follows:**

**109.7 Re-inspection Fee.** A fee as established by city council resolution may be charged when:

1. The inspection called for is not ready when the inspector arrives.
2. No building address or permit card is clearly posted.
3. City approved plans are not on the job site available to the inspector.
4. The building is locked or work otherwise not available for inspection when called.
5. The job site is red-tagged twice for the same item.
6. The original red tag has been removed from the job site.
7. Failure to maintain erosion control, trash control or tree protection.

Any re-inspection fees assessed shall be paid before any more inspections are made on that job site.

*(Reason: This fee is not a fine or penalty but is designed to compensate for time and trips when inspections are called for when not ready.)*

**\*\*Section 110.3.6; Lath, gypsum board and gypsum panel product inspection; Delete exception**

~~**Exception:** Gypsum board and gypsum panel products that are not part of a fire resistance rated assembly or a shear assembly.~~

*(Reason: Lath or gypsum board inspections are not typically performed in this area. Deleting the exception would then require all gypsum panels to be inspected)*

**\*\*Section 202; amend definition of Ambulatory Care Facility as follows:**

**AMBULATORY CARE FACILITY.** Buildings or portions thereof used to provide medical, surgical, psychiatric, nursing or similar care on a less than 24-hour basis to persons who are rendered incapable of self-preservation by the services provided ~~or staff has accepted responsibility for care recipients already incapable.~~ This group may include but not be limited to the following:

- Dialysis centers
- Sedation dentistry
- Surgery centers
- Colonic centers
- Psychiatric centers

*(Reason: To clarify the range of uses included in the definition. [Explanatory note related to **Ambulatory Care Facilities**: This group of uses includes medical or dental offices where persons are put under for dental surgery or other services. Section 903.2.2.1 will now require such uses to be sprinklered if on other than the floor of exit discharge or if*

four or more persons are put under on the level of exit discharge. Recommend (1.) jurisdictions document any pre-existing non-conforming conditions prior to issuing a new C of O for a change of tenant and, (2.) On any medical or dental office specify on C of O the maximum number of persons permitted to be put under general anesthesia. It is recommended that before a Certificate of Occupancy is issued, a letter of intended use from the business owner shall be included and a C of O documenting the maximum number of care recipients incapable of self-preservation allowed.)

**\*\*Section 202; add definition of Assisting Living Facilities to read as follows.**

**ASSISTED LIVING FACILITIES.** A building or part thereof housing persons, on a 24-hour basis, who because of age, mental disability or other reasons, live in a supervised residential environment which provides personal care services. The occupants are capable of responding to an emergency situation without physical assistance from staff.

*(Reason: The code references Assisted Living facilities and definition was deleted.)*

**Option A  
Section 202;**

**HIGH-RISE BUILDING. {No Change Required}**

**\*\*\*HIGH PILED COMBUSTIBLE STORAGE: add a second paragraph to read as follows:**

Any building classified as a group S occupancy or Speculative Building exceeding 12,000 sq.ft. that has a clear height in excess of 14 feet, making it possible to be used for storage in excess of 12 feet, shall be considered to be high-piled storage. When a specific product cannot be identified (speculative warehouse), a fire protection system and life safety features shall be installed as for Class IV commodities, to the maximum pile height.

*(Reason: To protect worst-case scenarios in flexible or unknown situations.)*

**Option B  
Section 202; amend definition to read as follows:**

**\*\*\*HIGH-PILED COMBUSTIBLE STORAGE: add a second paragraph to read as follows:**

Any building classified as a group S Occupancy or Speculative Building exceeding 6,000 sq. ft. that has a clear height in excess of 14 feet, making it possible to be used for storage in excess of 12 feet, shall be considered to be high-piled storage. When a specific product cannot be identified (speculative warehouse), a fire protection system and life safety features shall be installed for Class IV commodities, to the maximum pile height.

**HIGH-RISE BUILDING.** A building with an occupied floor or occupied roof located more than ~~75~~ 55 feet (~~22 860 mm~~) (16 764 mm) above the lowest level of fire

department vehicle access.

*(Reason: To define high-rise, as it influences sprinkler requirement thresholds based on the firefighting capabilities of a jurisdiction.)*

**\*\*Section 202; ~~add~~ amend definition of “Repair Garage” as follows:**

**REPAIR GARAGE.** A building, structure or portion thereof used for servicing or repairing motor vehicles. This occupancy shall also include garages involved in minor repair, modification and servicing of motor vehicles for items such as lube changes, inspections, windshield repair or replacement, shocks, minor part replacement and other such minor repairs.

*(Reason: The code references aligns with fire code.)*

**\*\*Section 202; amend definition of SPECIAL INSPECTOR to read as follows:**

**SPECIAL INSPECTOR.** A qualified person employed or retained by an approved agency who shall prove to the satisfaction of the registered design professional in responsible charge and approved by the Building Official as having the competence necessary to inspect a particular type of construction requiring special inspection.

*(Reason: The registered design professional in responsible charge should be included.)*

**\*\*Section 303.1.3; add a sentence to read as follows:**

**303.1.3 Associated with Group E occupancies.** A room or space used for assembly purposes that is associated with a Group E occupancy is not considered a separate occupancy, except when applying the assembly requirements of Chapters 10 and 11.

*(Reason: To clarify that egress and accessibility requirements are applicable for assembly areas, i.e. cafeteria, auditoriums, etc.)*

**\*\*Section 304.1; add the following to the list of occupancies:**

Fire stations

Police stations with detention facilities for 5 or less

*(Reason: Consistent with regional practice dating back to the legacy codes.)*

**\*\*Table 307.1.1; add the following sentence to Cleaning establishments with combustible liquid solvents** Cleaning establishments with combustible liquid solvents... {Text unchanged} ...with Section 707 or 1-hour horizontal assemblies constructed in accordance with Section 711 or both. See also IFC Chapter 21, Dry Cleaning Plant provisions.

*(Reason: To call attention to detailed requirements in the Fire Code.)*

**\*\*Section 403.1, Exception 3; change to read as follows:**

3. The open-air portion of a building [*remainder unchanged*]

*(Reason: To clarify enclosed portions are not exempt.)*

**\*\*Section 403.3, Automatic Sprinkler System. Delete exception.**

*(Reason: To provide adequate fire protection to enclosed areas.)*

**\*\*Section 403.3.2; change to read as follows:**

**403.3.2 Water Supply to required Fire Pumps.** In all buildings that are more than 420 feet (128 36.6 m) in building height, and ~~buildings of Type IVA and IVB construction that are more than 120 feet (36.6 m) in building height,~~ required fire pumps shall be supplied by connections to no fewer than two water mains located in different streets. Separate supply piping shall be provided between each connection to the water main and the pumps. Each connection and the supply piping between the connection and the pumps shall be sized to supply the flow and pressure required for the pumps to operate.

**Exception:** {No change to exception.}

*(Reason: The 2009 edition of the IFC added this requirement based on a need for redundancy of the water supply similar to the redundancy of the power supply to the fire pumps required for such tall buildings, partially due to the fact that these buildings are rarely fully evacuated in a fire event. More commonly, the alarm activates on the floor of the event, the floor above and the floor below. Back-up power to the fire pump becomes critical for this reason. Certainly, the power is pointless if the water supply is impaired for any reason, so a similar requirement is provided here for redundant water supplies. The 2015 edition changed the requirement to only apply to very tall buildings over 420 ft. This amendment modifies/lowers the requirement to 120 ft., based on this same height requirement for fire service access elevators. Again, the language from the 2009 and 2012 editions of the code applied to any high-rise building. This compromise at 120 ft. is based on the above technical justification of defend-in-place scenarios in fire incidents in such tall structures.)*

**\*\*Section 406.3.3.1 Carport separation; add sentence to read as follows:**

A fire separation is not required between a Group R-2 and U carport provided that the carport is entirely open on all sides and that the distance between the two is at least 10 feet (3048 mm).

*(Reason: Simplifies the fire separation distance and eliminates the need to obtain opening information on existing buildings when adding carports in existing apartment complexes.)*

*Consistent with legacy codes in effect in region for years and no record of problems with car fires spreading to apartments as a result.)*

**\*\*Section 503.1.; add sentence to read as follows:**

**503.1. General.** [Existing Text to remain]

Where a building contains more than one distinct type of construction, the building shall comply with the most restrictive area, height, and stories, for the lesser type of construction or be separated by fire walls, except as allowed in Section 510.

*(Reason: To create definite language that requires separation between dissimilar building types.)*

**\*\*Table 506.2; delete footnote i from table**

~~i. The maximum allowable area for a single-story non-sprinklered Group U greenhouse is permitted to be 9000 square feet or the allowable area shall be permitted to comply with Table C102.1 of Appendix C.~~

*(Reason: To eliminate the need for Appendix C adoption and remain consistent with 6000 sq. ft. sprinkling provision.)*

**\*\*Section 506.3.1; add sentence to read as follows:**

**506.3.1 Minimum percentage of perimeter.** [Existing Text remains]

In order to be considered as accessible, if not in direct contact with a street or fire lane, a minimum 10-foot-wide pathway meeting fire department access from the street or approved fire lane shall be provided.

*(Reason: To define what is considered accessible. Consistent with regional amendment to IFC 503.1.1)*

**\*\*Section 708.4.3; change sentence to read as follows:**

**708.4.3 Fireblocks and draftstops in combustible construction.** *[Body of text unchanged]*

**Exceptions:**

1. Buildings equipped with an automatic sprinkler system installed throughout in accordance with Section 903.3.1.1, or in accordance with Section 903.3.1.2 provided that sprinkler protection is provided in the space between the top of the fire partition and the underside of the floor or roof sheathing, deck or slab above as required for systems complying with Section 903.3.1.1. Portions of buildings containing concealed spaces filled with noncombustible insulation as permitted for sprinkler omission shall not apply to this exception for draftstopping. *[Remainder unchanged]*

*Reason: The most common exception used to eliminate the need for sprinklers in concealed spaces of combustible construction is to fill the space with noncombustible insulation. This exception was changed in 2010 to permit a 2-inch air gap at the top of the filled space. A space compliant with the permitted omission above would allow hot gas and smoke to spread unimpeded throughout a building not provided with draftstopping. For this reason, omission of sprinklers permitted in accordance with NFPA 13 referenced standard should not be permitted with IBC exception requiring draftstopping in combustible construction.*

**\*\*Section 718.3; change sentence to read as follows:**

**718.3 Draftstops in floors.** *[Body of text unchanged]*

**Exceptions:** Buildings equipped throughout with an automatic sprinkler system in accordance with Section 903.3.1.1. and provided that in combustible construction, sprinkler protection is provided in the floor space.

*(Reason: To remain consistent with changes in 708.4.3 IBC code.)*

**\*\*Section 718.4; change sentence to read as follows:**

**718.4 Draftstops in attics.** *[Body of text unchanged]*

**Exceptions:** Buildings equipped throughout with an automatic sprinkler system in accordance with Section 903.3.1.1 and provided that in combustible construction, sprinkler protection is provided in the attic space.

*(Reason: To remain consistent with changes in 708.4.3 IBC code.)*

**\*\*Section 901.6.1.1; add to read as follows:**

**901.6.1.1 Standpipe Testing.** Building owners/managers must maintain and test standpipe systems as per NFPA 25 requirements. The following additional requirements shall be applied to the testing that is required every 5 years:

1. The piping between the Fire Department Connection (FDC) and the standpipe shall be backflushed or inspected by approved camera when foreign material is present or when caps are missing, and also hydrostatically tested for all FDC's on any type of standpipe system. Hydrostatic testing shall also be conducted in accordance with NFPA 25 requirements for the different types of standpipe systems.
2. For any manual (dry or wet) standpipe system not having an automatic water supply capable of flowing water through the standpipe, the tester shall connect hose from a fire hydrant or portable pumping system (as approved by the *fire code official*) to each FDC, and flow water through the standpipe system to the roof outlet to verify that each inlet connection functions properly. Confirm that there are

no open hose valves prior to introducing water into a dry standpipe. There are no required pressure criteria at the outlet. Verify that check valves function properly and that there are no closed control valves on the system.

3. Any pressure relief, reducing, or control valves shall be tested in accordance with the requirements of NFPA 25. All hose valves shall be exercised.
4. If the FDC is not already provided with approved caps, the contractor shall install such caps for all FDC's as required by the *fire code official*.
5. Upon successful completion of standpipe test, place a blue tag (as per Texas Administrative Code, Fire Sprinkler Rules for Inspection, Test and Maintenance Service (ITM) Tag) at the bottom of each standpipe riser in the building. The tag shall be check-marked as "Fifth Year" for Type of ITM, and the note on the back of the tag shall read "5 Year Standpipe Test" at a minimum.
6. The procedures required by Texas Administrative Code Fire Sprinkler Rules with regard to Yellow Tags and Red Tags or any deficiencies noted during the testing, including the required notification of the local Authority Having Jurisdiction (*fire code official*) shall be followed.
7. Additionally, records of the testing shall be maintained by the owner and contractor, if applicable, as required by the State Rules mentioned above and NFPA 25.
8. Standpipe system tests where water will be flowed external to the building shall not be conducted during freezing conditions or during the day prior to expected nighttime freezing conditions.
9. Contact the *fire code official* for requests to remove existing fire hose from Class II and III standpipe systems where employees are not trained in the utilization of this firefighting equipment. All standpipe hose valves must remain in place and be provided with an approved cap and chain when approval is given to remove hose by the *fire code official*.

*(Reason: Increases the reliability of the fire protection system and re-emphasizes the requirements of NFPA 25 relative to standpipe systems, as well as ensuring that FDC connections are similarly tested/maintained to ensure operation in an emergency incident.)*

**\*\*Section 901.6.4; add to read as follows:**

**901.6.4 False Alarms and Nuisance Alarms.** False alarms and nuisance alarms shall not be given, signaled or transmitted or caused or permitted to be given, signaled or transmitted in any manner.

*(Reason: Places the responsibility on the business or property owner to maintain their fire alarm systems in approved condition. Allows the enforcement of "prohibition of false alarms". Replaces text lost from the legacy codes that helps to ensure the maintenance of life safety systems.)*

**\*\*Section 901.7; change to read as follows:**

**901.7 Systems Out of Service.** Where a required *fire protection system* is out of service or in the event of an excessive number of activations, the fire department and the *fire code official* shall be notified immediately and, where required by the *fire code official*, the building shall either be evacuated or an *approved fire watch* shall be provided for all occupants left unprotected by the shut down until the *fire protection system* has been returned to service. ... {Remainder of section unchanged}}

*(Reason: Gives fire code official more discretion with regards to enforcement of facilities experiencing nuisance alarm or fire protection system activations necessitating correction/repair/replacement. The intent of the amendment is to allow local jurisdictions to enforce fire watches, etc., where needed to ensure safety of occupants where fire protection systems are experiencing multiple nuisance activations.)*

**\*\*Section 903.1.1; change to read as follows:**

**903.1.1 Alternative Protection.** Alternative automatic fire-extinguishing systems complying with Section 904 shall be permitted instead of in addition to automatic sprinkler protection where recognized by the applicable standard and, or as approved by the *fire code official*.

*(Reason: Such alternative systems do not provide the reliability of automatic sprinkler protection. Most gaseous type systems are highly susceptible to open doors, ceiling or floor tile removal, etc. However, an applicant could pursue an Alternate Method request to help mitigate the reliability issues with these alternative systems with the fire code official if so desired, or there may be circumstances in which the fire code official is acceptable to allowing an alternate system in lieu of sprinklers, such as kitchen hoods or paint booths.)*

**\*\*Section 903.2; add paragraph to read as follows and delete the Exception:**

**903.2 Where required.** Approved automatic sprinkler systems in new buildings and structures shall be provided in the locations described in Sections 903.2.1 through 903.2.12. Automatic Sprinklers shall not be installed in elevator machine rooms, elevator machine spaces, and elevator hoistways, other than pits where such sprinklers would not necessitate shunt trip requirements under any circumstances.

Exception: Spaces or areas in telecommunications buildings used exclusively for telecommunications equipment, associated electrical power distribution equipment, batteries not required to have an automatic sprinkler system by Section 1207 for energy storage systems and standby engines, provided that those spaces or areas are equipped throughout with an automatic smoke detection system in accordance with Section 907.2 and are separated from the remainder of the building by not less than 1-hour fire barriers

~~constructed in accordance with Section 707 of the International Building Code or not less than 2-hour horizontal assemblies constructed in accordance with Section 711 of the International Building Code, or both.~~

*(Reason: To ensure firefighter and public safety. This amendment eliminates the shunt trip requirement of International Building Code Section 3005.5 for the purpose of elevator passenger and firefighter safety. This amendment is contingent on the Building Code amendment eliminating the exceptions to Section 403.3 and Section 3005.4, such that passive fire barriers for these areas are maintained. (The exception deletion is due to the fact that such areas pose an undue fire risk to the structural integrity of the building.)*

**\*\*\*Section 903.2.2.1; change exception to read as follows:**

**903.2.2.1 Ambulatory care facilities.** An automatic sprinkler system shall be installed throughout the entire floor containing an ambulatory care facility where either of the following conditions exist at any time:

1. Four or more care recipients are incapable of self-preservation.
2. One or more care recipients that are incapable of self-preservation are located at other than the level of exit discharge serving such a facility.

In buildings where ambulatory care is provided on levels other than the level of exit discharge, an automatic sprinkler system shall be installed throughout the entire floor as well as all floors below where such care is provided, and all floors between the level of ambulatory care and the nearest level of exit discharge, the level of exit discharge, and all floors below the level of exit discharge.

Exception: Unless otherwise required by this code, floors classified as an open parking garage are not required to be sprinklered.

*(Reason: To ensure that parking garages that are otherwise required to have automatic fire sprinkler protection are not unintendedly exempt by this exception.)*

**\*\*\*Section 903.2.4.2; change to read as follows:**

**903.2.4.2 Group F-1 distilled spirits.** An automatic sprinkler system shall be provided throughout a Group F-1 fire area used for the manufacture of distilled spirits involving more than 120 gallons of distilled spirits (>20% alcohol) in the fire area at any one time.

*(Reason: To establish a sprinkler criteria limit based on existing maximum allowable quantities provided for flammable liquids in a non-sprinklered space from Chapter 50 and allow very small distillery type operations without sprinkler requirements as has been historically allowed.)*

**\*\*\*Section 903.2.9.3; change to read as follows:**

**903.2.9.3 Group S-1 distilled spirits or wine.** An automatic sprinkler system shall be provided throughout a Group S-1 fire area used for the bulk storage of distilled spirits or wine involving more than 120 gallons of distilled spirits or wine (>20% alcohol) in the fire area at any one time.

*(Reason: To establish a sprinkler criteria limit based on existing maximum allowable quantities provided for flammable liquids in a non-sprinklered space from Chapter 50 and allow very small storage operations without sprinkler requirements as has been historically allowed.)*

**\*\*Section 903.2.9.4; delete Exception:**

**903.2.9.4 Group S-1 upholstered furniture and mattresses.** An automatic sprinkler system shall be provided throughout a Group S-1 fire area where the area used for the storage of upholstered furniture or mattresses exceeds 2,500 square feet (232 m<sup>2</sup>).

~~**Exception:** Self-service storage facilities not greater than one story above grade plane where all storage spaces can be accessed directly from the exterior.~~

*(Reason: Fire departments are unable to regularly inspect the interior of these commercial occupancies and are unaware of the contents being stored.)*

**\*\*\*Section 903.2.9.5; add to read as follows:**

**903.2.9.5 Self-Service Storage Facility.** An automatic sprinkler system shall be installed throughout all self-service storage facilities. The minimum sprinkler system design shall be based on an Ordinary Hazard Group II classification, in accordance with NFPA 13 requirements. Physical construction in compliance with open-grid ceilings as per NFPA 13, such as an open metal grid ceiling or chicken wire that does not obstruct the overhead sprinkler protection, shall be installed to prevent storage from exceeding the lower of either 12 feet above finished floor or 18 inches beneath standard sprinkler head deflectors. At least one sprinkler head shall be provided in each storage unit/room (additional sprinklers may be necessary for compliance with NFPA 13 spacing requirements), regardless of wall height or construction type separating such units.

*(Reason: Fire departments are unable to regularly inspect the interior of these commercial occupancies and are unaware of the contents being stored. The physical obstruction specification is to ensure maximum storage heights are not exceeded in these self-storage occupancies where enforcement of such has shown to be historically problematic for fire code officials and building managers.)*

**\*\*Option A**

**Section 903.2.11; change 903.2.11.3 and add 903.2.11.7 and 903.2.11.8, as follows:**

**903.2.11.3 Buildings 55 Feet or more in Height.** An automatic sprinkler system shall be installed throughout buildings that have one or more stories ~~with an occupant load of 30 or more,~~ other than penthouses in compliance with Section 1511 of the *International Building Code*, located 55 feet (16 764 mm) or more above the lowest level of fire department vehicle access, measured to the finished floor.

**Exception:**

- ~~1. Occupancies in Group F-2.~~

**903.2.11.7 High-Piled Combustible Storage.** For any building with a clear height exceeding 12 feet (4572 mm), see Chapter 32 to determine if those provisions apply.

**903.2.11.8 Spray Booths and Rooms.** New and existing spray booths and spraying rooms shall be protected by an approved automatic fire-extinguishing system.

**\*\*\*Option B**

**Section 903.2.11; change 903.2.11.3 and add 903.2.11.7, 903.2.11.8, and 903.2.11.9 as follows:**

**903.2.11.3 Buildings ~~55~~ 35 feet or more in height.** An automatic sprinkler system shall be installed throughout buildings that have one or more stories ~~with an occupant load of 30 or more,~~ other than penthouses in compliance with Section 1511 of the *International Building Code*, located ~~55~~ 35 feet (16 764 10 668 mm) or more above the lowest level of fire department vehicle access, measured to the finished floor.

**Exception:**

- ~~1. Occupancies in Group F-2.~~

**903.2.11.7 High-Piled Combustible Storage.** For any building with a clear height exceeding 12 feet (4572 mm), see Chapter 32 to determine if those provisions apply.

**903.2.11.8 Spray Booths and Rooms.** New and existing spray booths and spraying rooms shall be protected by an approved automatic fire-extinguishing system.

**903.2.11.9 Buildings Over 6,000 sq. ft.** An automatic sprinkler system shall be installed throughout all buildings with a building area 6,000 sq. ft. or greater and in

all existing buildings that are enlarged to be 6,000 sq. ft. or greater. For the purpose of this provision, fire walls shall not define separate buildings.

Exception: Open parking garages complying with 903.2.10

*(Reason: Provides jurisdictions options as to their desired level of sprinkler protection based on multiple factors including firefighting philosophies/capabilities.)*

**\*\*\*Section 903.3.1.1.1; change to read as follows:**

**903.3.1.1.1 Exempt Locations.** When approved by the fire code official, automatic sprinklers shall not be required in the following rooms or areas where such ... *{text unchanged}*... because it is damp, of fire-resistance-rated construction or contains electrical equipment.

1. A room or space where sprinklers constitute a serious life or fire hazard because of the nature of the contents, where approved by the fire code official.
2. Generator and transformer rooms, under the direct control of a public utility, separated from the remainder of the building by walls and floor/ceiling or roof/ceiling assemblies having a fire-resistance rating of not less than 2 hours.
- ~~3. Rooms or areas that are of noncombustible construction with wholly noncombustible contents.~~
4. ~~Fire service access~~ Elevator machine rooms, and machinery spaces, and hoistways, other than pits where such sprinklers would not necessitate shunt trip requirements under any circumstances.
- ~~5. Machine rooms, machinery spaces, control rooms and control spaces associated with occupant evacuation elevators designed in accordance with Section 3008 of the International Building Code.~~

*(Reason: Gives more direction to code official. Exception 3 deleted to provide protection where fire risks are poorly addressed. Amendment 903.2 addresses Exception 5 above relative to the elimination of sprinkler protection in these areas to avoid the shunt trip requirement.)*

**\*\*\*Section 903.3.1.1.4; add the following Section:**

**903.3.1.1.4 Dry pipe sprinkler systems.** Dry pipe sprinkler systems protecting fire areas of Type V construction shall be required to meet the 60 second water delivery time, per NFPA 13, to the system test connection regardless of the system size, unless more stringent criteria are applicable in NFPA 13, and all dry pipe sprinkler systems shall be trip tested to flow/discharge water to verify compliance with this requirement, unless otherwise approved by the fire code official.

*(Reason: This provision is limited to Type V construction due to the unique need discharge water on to light weight wood construction members for rapid fire control. This*

requirement for dry system trip tests to guarantee water delivery times across all system sizes. Faster water delivery improves fire control capabilities by supplying water before the growing fire size overwhelms the fire sprinklers. The water delivery time test aids in identifying any delays in water reaching the fire in dry pipe systems, detecting any blockages in the pipe network, and ensuring the dry pipe valve is in good condition.)

**\*\*Section 903.3.1.2.2; change to read as follows:**

**903.3.1.2.2 Corridors and balconies in the means of egress.** Sprinkler protection shall be provided in all corridors and for all balconies. ~~in the means of egress where any of the following conditions apply:~~

- ~~1. Corridors with combustible floor or walls.~~
- ~~2. Corridors with an interior change of direction exceeding 45 degrees (0.79 rad).~~
- ~~3. Corridors that are less than 50 percent open to the outside atmosphere at the ends.~~
- ~~4. Open-ended corridors and associated exterior stairways and ramps as specified in Section 1027.6, Exception 3.~~
- ~~5. Egress balconies not complying with Sections 1021.2 and 1021.3.~~

*(Reason: Corridor protection is critical to the means of egress, and corridors are regularly utilized for miscellaneous storage, fixtures, artwork, food kiosks and beverage dispensers, and furnishings. Balcony protection is required due to issues with fire exposure via soffit vents and the potential for significant combustibles loading.)*

**\*\*Section 903.3.1.2.3; delete section and replace as follows:**

**Section 903.3.1.2.3 Attached Garages and Attics.** Sprinkler protection is required in attached garages, and in the following attic spaces:

1. Attics that are used or intended for living purposes or storage shall be protected by an automatic sprinkler system.
2. Where fuel-fired equipment is installed in an unsprinklered attic, not fewer than one quick-response intermediate temperature sprinkler shall be installed above the equipment.
3. Attic spaces of buildings that are two or more stories in height above grade plane or above the lowest level of fire department vehicle access.
4. Group R-4, Condition 2 occupancy attics not required by Item 1 or 3 to have sprinklers shall comply with one of the following:
  - 4.1. Provide automatic sprinkler system protection.
  - 4.2. Provide a heat detection system throughout the attic that is arranged to activate the building fire alarm system.
  - 4.3. Construct the attic using noncombustible materials.
  - 4.4. Construct the attic using fire-retardant-treated wood complying with Section 2303.2 of the International Building Code.
  - 4.5. Fill the attic with noncombustible insulation.

*(Reason: Attic protection is required due to issues with fire exposure via soffit vents, as well as firefighter safety. Several jurisdictions indicated experience with un-protected attic fires resulting in displacement of all building occupants. NFPA 13 provides for applicable attic sprinkler protection requirements, as well as exemptions to such, based on noncombustible construction, etc. Attached garages already require sprinklers via NFPA 13R – this amendment just re-emphasizes the requirement.)*

**\*\*Section 903.3.1.3; change to read as follows:**

**903.3.1.3 NFPA 13D Sprinkler Systems.** Automatic sprinkler systems installed in one- and two-family dwellings; Group R-3; Group R-4, Condition 1; and townhouses shall be permitted to be installed throughout in accordance with NFPA 13D or in accordance with state law.

*(Reason: To allow the use of the Plumbing section of the International Residential Code (IRC) and recognize current state stipulations in this regard.)*

**\*\*\*Section 903.3.1.4; add to read as follows:**

**903.3.1.4 Freeze protection.** Freeze protection systems for automatic fire sprinkler systems shall be in accordance with the requirements of the applicable referenced NFPA standard and this section.

**903.3.1.4.1 Attics.** Only dry-pipe, preaction, or listed antifreeze automatic fire sprinkler systems shall be allowed to protect unheated attic spaces.

**Exception:** Wet-pipe fire sprinkler systems shall be allowed to protect non-ventilated attic spaces where:

1. The attic sprinklers are supplied by a separate floor control valve assembly to allow ease of draining the attic system without impairing sprinklers throughout the rest of the building, and
2. Adequate heat shall be provided for freeze protection as per the applicable referenced NFPA standard, and
3. The attic space is a part of the building's thermal, or heat, envelope, such that insulation is provided at the roof deck, rather than at the ceiling level.

**903.3.1.4.2 Heat trace/insulation.** Heat trace/insulation shall only be allowed where approved by the fire code official for small sections of large diameter water-filled pipe.

*(Reason: In the last few years, severe winters brought to light several issues with current practices for sprinklering attics, not the least of which was wet-pipe sprinklers in ventilated attics provided with space heaters, etc. for freeze protection of such piping. This practice is not acceptable for the protection of water-filled piping in a ventilated attic space as it does not provide a reliable means of maintaining the minimum 40 degrees required by NFPA, wastes energy, and presents a potential ignition source to the attic space. The*

*intent of this amendment is to help reduce the large number of freeze breaks that have occurred in the past with water-filled wet-pipe sprinkler systems in the future, most specifically in attic spaces.)*

**\*\*Section 903.3.5; add a second paragraph to read as follows:**

Water supply as required for such systems shall be provided in conformance with the supply requirements of the respective NFPA standards; however, every water-based fire protection system shall be designed with a 10-psi safety factor. Reference Section 507.4 for additional design requirements.

*(Reason: To define uniform safety factor for the region.)*

**\*\*\*Section 903.3.9; change to read as follows:**

**903.3.9 High-rise Building floor control valves.** Approved supervised indicating control valves shall be provided at the point of connection to the riser as indicated below: ~~in high-rise buildings~~

1. In High Rise Buildings, floor control assemblies shall be located in protected stairwells, or as otherwise approved by the fire code official.
2. In all other buildings, floor control assemblies shall be located as approved by the fire code official.

*(Reason: Intent is to allow the ability to drain each floor's sprinkler system without draining the entire system, as well as to isolate each floor in the event of an impairment, such that only one floor is impaired at a time.)*

**\*\*\*Section 903.4.1; add a second paragraph after the Exceptions to read as follows:**

Sprinkler and standpipe system water-flow detectors shall be provided for each floor tap to the sprinkler system and shall cause an alarm upon detection of water flow for more than 45 seconds. Reference Section 903.3.9 for required floor control assemblies. All control valves in the sprinkler and standpipe systems except for fire department hose connection valves shall be electrically supervised to initiate a supervisory signal at the central station upon tampering.

*(Reason: To avoid significant water losses, reduce false alarms, and eliminate undetected tampering of water supplies. Consistent with amendment to IFC 905.9.)*

**\*\*Section 903.4.3; add second paragraph to read as follows:**

The alarm device required on the exterior of the building shall be a weatherproof horn/strobe notification appliance with a minimum 75 candela strobe rating, installed as close as practicable to the fire department connection.

*(Reason: Fire department connections are not always located at the riser; this allows the fire department faster access and ease of recognition of the FDC location, especially at night.)*

**\*\*\*Section 905.3.8; add to read as follows:**

**905.3.8 Buildings Exceeding 10,000 sq. ft.** In buildings exceeding 10,000 square feet in area per story and where any portion of the building's interior area is more than 200 feet (60960 mm) of travel, vertically and horizontally, from the nearest point of fire department vehicle access, Class I standpipes shall be provided.

*(Reason: Allows for the rapid deployment of hose lines to the body of the fire in larger structures.)*

**\*\*\*Section 905.4; change Item 5, and add Item 7 to read as follows:**

5. Where the roof has a slope less than 4 units vertical in 12 units horizontal (33.3-percent slope), each standpipe shall be provided with a two-way a-hose connection ~~shall be~~ located to serve the roof or at the highest landing of an interior exit stairway with stair access to the roof provided in accordance with Section 1011.12.
6. {No change.}
7. When required by this Chapter, standpipe connections shall be placed adjacent to all required exits to the structure and at two hundred feet (200') intervals along major corridors thereafter, or as otherwise approved by the fire code official.

*(Reason: Item 5 reduces the amount of pressure required to facilitate the required testing of NFPA 14 and 25, and provides backup protection for fire fighter safety. Item 7 allows for the rapid deployment of hose lines to the body of the fire.)*

**\*\*Section 905.8; change to read as follows:**

**905.8 Dry standpipes.** Dry standpipes shall not be installed.

**Exception:** Where subject to freezing and in accordance with NFPA 14. Additionally, manual dry standpipe systems shall be supervised with a minimum of 10 psig and a maximum of 40 psig air pressure with a high/low Supervisory alarm.

*(Reason: To define manual dry standpipe supervision requirements. Helps ensure the integrity of the standpipe system via supervision, such that open hose valves will result in a supervisory low air alarm. NFPA 14 requires supervisory air for such, but does not provide pressure criteria for what that means.)*

**\*\*Section 905.9; add a second paragraph after the exceptions to read as follows:**

Sprinkler and standpipe system water-flow detectors shall be provided for each floor tap to the sprinkler system and shall cause an alarm upon detection of water flow for more than 45 seconds. Reference Section 903.3.9 for required floor control assemblies. All control valves in the sprinkler and standpipe systems except for fire department hose connection valves shall be electrically supervised to initiate a supervisory signal at the central station upon tampering.

*(Reason: To avoid significant water losses. Consistent with amendment to IFC 903.4.1)*

**\*\*Section 906.1(1); delete Exception 3 as follows:**

~~3. In storage areas of Group S occupancies where forklift, powered industrial truck or powered cart operators are the primary occupants, fixed extinguishers, as specified in NFPA 10, shall not be required where in accordance with all of the following:~~

- ~~3.1. Use of vehicle-mounted extinguishers shall be approved by the fire code official.~~
- ~~3.2. Each vehicle shall be equipped with a 10 pound, 40A:80B:C extinguisher affixed to the vehicle using a mounting bracket approved by the extinguisher manufacturer or the fire code official for vehicular use.~~
- ~~3.3. Not less than two spare extinguishers of equal or greater rating shall be available on-site to replace a discharged extinguisher.~~
- ~~3.4. Vehicle operators shall be trained in the proper operation, use and inspection of extinguishers.~~
- ~~3.5. Inspections of vehicle-mounted extinguishers shall be performed daily.~~

*(Reason: This provision of only having vehicle-mounted fire extinguishers is not at all consistent with the practice of requiring extinguishers throughout based on travel distance. Often times, the vehicle is what has caused the incident and/or may be the source of the incident, so having the extinguisher vehicle-mounted results in greater potential injury of the user. This assumes the only occupants in the building are on a vehicle, which again, significantly reduces access to fire extinguishers throughout the building to other occupants. Future use of the building/tenancy may change further complicating the issue.)*

**\*\*\*Section 907.1.4; add to read as follows:**

**907.1.4 Design Standards.** Where a new fire alarm system is installed, the devices shall be addressable.

*(Reason: Provides for the ability of descriptive identification of alarms.)*

**\*\*\*Section 907.2.1; change to read as follows:**

**907.2.1 Group A.** A manual fire alarm system that activates the occupant notification system in accordance with Section 907.5 shall be installed in Group A occupancies ~~where the having an occupant load due to the assembly occupancy is of 300 or more persons,~~ or where the Group A occupant load is more than 100 persons above or below the *lowest level of exit discharge*. Group A occupancies not separated from one another in accordance with Section 707.3.10 of the *International Building Code* shall be considered as a single occupancy for the purposes of applying this section. Portions of Group E occupancies occupied for assembly purposes shall be provided with a fire alarm system

as required for the Group E occupancy.

**Exceptions:** {No change.}

*(Reason: Increases the requirement to be consistent with Group B requirement.)*

---

**\*\*Section 907.2.3; change to read as follows:**

**907.2.3 Group E.** A manual fire alarm system that initiates the occupant notification signal utilizing an emergency voice/alarm communication system meeting the requirements of Section 907.5.2.2 and installed in accordance with Section 907.6 shall be installed in Group E educational occupancies. When *automatic sprinkler systems* or smoke detectors are installed, such systems or detectors shall be connected to the building fire alarm system. An approved smoke detection system shall be installed in Group E day care occupancies. Unless separated by a minimum of 100' open space, all buildings, whether portable buildings or the main building, will be considered one building for alarm occupant load consideration and interconnection of alarm systems.

**Exceptions:**

1. {No change.}

1.1. Residential In-Home day care with not more than 12 children may use interconnected single station detectors in all habitable rooms. (For care of more than five children 2 1/2 or less years of age, see Section 907.2.6.)

{No change to remainder of exceptions.}

*(Reason: To distinguish educational from day care occupancy minimum protection requirements. Further, to define threshold at which portable buildings are considered a separate building for the purposes of alarm systems. Exceptions provide consistency with State law concerning such occupancies.)*

---

**\*\*\*Section 907.2.10.1; change to read as follows:**

**907.2.10.1 Public- and Self-Storage Occupancies.** A manual fire alarm system that activates the occupant notification system in accordance with Section 907.5 shall be installed in Group S public- and self-storage occupancies ~~three stories or greater in height~~ for interior corridors and interior common areas. Visible notification appliances are not required within storage units.

Exception: {No change.}

*(Reason: Because of the potential unknown fire load and hazards in self-storage type facilities, which could include flammable liquids for instance, as well as other hazardous materials, prompt evacuation in the event of fire alarm is needed; therefore, notification in the corridors/common areas is critical to all such occupancies, regardless of height.)*

---

**\*\*Section 907.2.13, Exception #3; change to read as follows:**

3. Open air portions of buildings with an occupancy in Group A-5 in accordance with Section 303.1 of the *International Building Code*; however, this exception does not

apply to accessory uses including but not limited to sky boxes, restaurants, and similarly enclosed areas.

*(Reason: To indicate that enclosed areas within open air seating type occupancies are not exempted from automatic fire alarm system requirements.)*

**\*\*Section 907.4.2.7; add to read as follows:**

**907.4.2.7 Type.** Manual alarm initiating devices shall be an approved double action type.

*(Reason: Helps to reduce false alarms.)*

**\*\*Section 907.6.1.1; add to read as follows:**

**907.6.1.1 Wiring Installation.** All fire alarm systems shall be installed in such a manner that a failure of any single initiating device or single open in an initiating circuit conductor will not interfere with the normal operation of other such devices. All signaling line circuits (SLC) shall be installed in such a way that a single open will not interfere with the operation of any addressable devices (Class A). Outgoing and return SLC conductors shall be installed in accordance with NFPA 72 requirements for Class A circuits and shall have a minimum of four feet separation horizontal and one foot vertical between supply and return circuit conductors. The initiating device circuit (IDC) from a signaling line circuit interface device may be wired Class B, provided the distance from the interface device to the initiating device is ten feet or less.

*(Reason: To provide uniformity in system specifications and guidance to design engineers. Improves reliability of fire alarm devices and systems.)*

**\*\*Section 907.6.3; delete all four Exceptions.**

**907.6.3 Initiating device identification.** The fire alarm system shall identify the specific initiating device address, location, device type, floor level where applicable and status including indication of normal, alarm, trouble and supervisory status, as appropriate.

**Exceptions:**

- ~~1. Fire alarm systems in single-story buildings less than 22,500 square feet (2090 m<sup>2</sup>) in area.~~
- ~~2. Fire alarm systems that only include manual fire alarm boxes, waterflow initiating devices and not more than 10 additional alarm-initiating devices.~~
- ~~3. Special initiating devices that do not support individual device identification.~~
- ~~4. Fire alarm systems or devices that are replacing existing equipment.~~

*(Reason: To assist responding personnel in locating the emergency event for all fire alarm systems.)*

**\*\*Section 907.6.6; add sentence at end of paragraph to read as follows:**

See 907.6.3 for the required information transmitted to the supervising station.

*(Reason: To assist responding personnel in locating the emergency event for all fire alarm systems.)*

**\*\*Section 910.2.3; add to read as follows:**

**910.2.3 Group H.** Buildings and portions thereof used as a Group H occupancy as follows:

1. In occupancies classified as Group H-2 or H-3, any of which are more than 15,000 square feet (1394 m<sup>2</sup>) in single floor area.

**Exception:** Buildings of noncombustible construction containing only noncombustible materials.

2. In areas of buildings in Group H used for storing Class 2, 3, and 4 liquid and solid oxidizers, Class 1 and unclassified detonable organic peroxides, Class 3 and 4 unstable (reactive) materials, or Class 2 or 3 water-reactive materials as required for a high-hazard commodity classification.

**Exception:** Buildings of noncombustible construction containing only noncombustible materials.

*(Reason: Maintains a fire protection device utilized in such occupancies where it is sometimes necessary to allow chemicals to burn out, rather than extinguish. This is based on legacy language establishing long-standing historical practice.)*

**\*\*Section 910.4.3.1; change to read as follows:**

**910.4.3.1 Makeup Air.** Makeup air openings shall be provided within 6 feet (1829 mm) of the floor level. Operation of makeup air openings shall be ~~manual or~~ automatic. The minimum gross area of makeup air inlets shall be 8 square feet per 1,000 cubic feet per minute (0.74 m<sup>2</sup> per 0.4719 m<sup>3</sup>/s) of smoke exhaust.

*(Reason: Makeup air has been required to be automatic for several years now in this region when mechanical smoke exhaust systems are proposed. This allows such systems to be activated from the smoke control panel by first responders without having to physically go around the exterior of the building opening doors manually. Such requires a significant number of first responders on scene to conduct this operation and significantly delays activation and/or capability of the smoke exhaust system.)*

**\*\*Section 912.2.3; add to read as follows:**

**912.2.3 Hydrant Distance.** An approved fire hydrant shall be located within 100 feet of the fire department connection as the fire hose lays along an unobstructed path.

*(Reason: To accommodate limited hose lengths, improve response times where the FDC is needed to achieve fire control, and improve ease of locating a fire hydrant in those situations also. Also, consistent with NFPA 14 criteria.)*

**\*\*Section 913.2.1; add second paragraph and exception to read as follows:**

When located on the ground level at an exterior wall, the fire pump room shall be provided with an exterior fire department access door that is not less than 3 ft. in width and 6 ft. – 8 in. in height, regardless of any interior doors that are provided. A key box shall be provided at this door, as required by Section 506.1.

**Exception:** When it is necessary to locate the fire pump room on other levels or not at an exterior wall, the corridor leading to the fire pump room access from the exterior of the building shall be provided with equivalent fire resistance as that required for the pump room, or as approved by the fire code official. Access keys shall be provided in the key box as required by Section 506.1.

*(Reason: This requirement allows firefighters safer access to the fire pump room. The requirement allows access without being required to enter the building and locate the fire pump room interior access door during a fire event. The exception recognizes that this will not always be a feasible design scenario and as such, provides an acceptable alternative to protect the pathway to the fire pump room.)*

**\*\*Section 914.3.1.2; add section:**

**914.3.1.2 Water Supply to required Fire Pumps.** In all buildings that are more than 420 120 feet (128 36.6 m) in building height, and ~~buildings of Type IVA and IVB construction that are more than 120 feet (36.6 m) in building height,~~ required fire pumps shall be supplied by connections to no fewer than two water mains located in different streets. Separate supply piping shall be provided between each connection to the water main and the pumps. Each connection and the supply piping between the connection and the pumps shall be sized to supply the flow and pressure required for the pumps to operate.

**Exception:** {No change to exception.}

*(Reason: The 2009 edition of the IFC added this requirement based on a need for redundancy of the water supply similar to the redundancy of the power supply to the fire pumps required for such tall buildings, partially due to the fact that these buildings are rarely fully evacuated in a fire event. More commonly, the alarm activates on the floor of the event, the floor above and the floor below. Back-up power to the fire pump becomes critical for this reason. Certainly, the power is pointless if the water supply is impaired for*

any reason, so a similar requirement is provided here for redundant water supplies. The 2015 edition changes the requirement to only apply to very tall buildings over 420 ft. This amendment modifies/lowers the requirement to 120 ft., based on this same height requirement for fire service access elevators. Again, the language from the 2009 and 2012 editions of the code applied to any high-rise building. This compromise at 120 ft. is based on the above technical justification of defend-in-place scenarios in fire incidents in such tall structures.)

**\*\*\*Section 915 Carbon Monoxide (CO) Detection; delete and replace to read as follows:**

**915.1 General.** New and existing buildings shall be provided with carbon monoxide (CO) detection in accordance with Sections 915.2 through 915.5.

**915.2 Where required.** Carbon monoxide detection shall be provided in interior spaces, other than dwelling units or sleeping units, that are exposed to a carbon monoxide source in accordance with Sections 915.2.1 through 915.2.3. Carbon monoxide detection for dwelling units or sleeping units that are exposed to a carbon monoxide source shall be in accordance with Section 915.2.4.

**915.2.1 Interior spaces with direct carbon monoxide sources.** In all occupancies, interior spaces with a direct carbon monoxide source shall be provided with carbon monoxide detection located in close proximity to the direct carbon monoxide source and in accordance with Section 915.3.

Exception: Where environmental conditions in an enclosed space are incompatible with carbon monoxide detection devices, carbon monoxide detection shall be provided in an approved adjacent location.

**915.2.2 Interior spaces adjacent to a space containing a carbon monoxide source.** In Groups A, B, E, I, M and R Occupancies, interior spaces that are separated from and adjacent to an enclosed parking garage or an interior space that contains a direct carbon monoxide source shall be provided with carbon monoxide detection if there are communicating openings between the spaces. Detection devices shall be located in close proximity to communicating openings on the side that is furthest from the carbon monoxide source and in accordance with Section 915.3

**Exceptions:**

1. Where communicating openings between the space containing a direct carbon monoxide source and the adjacent space are permanently sealed airtight, carbon monoxide detection is not required for the adjacent space.
2. Where the fire code official determines that the volume or configuration of the adjacent interior space is such that dilution or geometry would diminish the effectiveness of carbon monoxide detection devices located in such spaces, detection devices additional to those required by Section 915.2.1 shall be located on the side of communicating openings that is closest to the carbon monoxide source.

**915.2.3 Interior spaces with forced-indirect carbon monoxide sources.** In all occupancies, interior spaces with a forced-indirect carbon monoxide source shall be provided with carbon monoxide detection in accordance with either of the following:

1. Detection in each space with a forced-indirect carbon monoxide source, located in accordance with Section 915.3.
2. Detection only in the first space served by the main duct leaving the forced-indirect carbon monoxide source, located in accordance with Section 915.3, with an audible and visual alarm signal provided at an approved location.

**915.2.4 Dwelling units and sleeping units.** Carbon monoxide detection for dwelling units and sleeping units shall comply with Sections 915.2.4.1 and 915.2.4.2.

**915.2.4.1 Direct carbon monoxide sources.** Where a direct carbon monoxide source is located in a bedroom or sleeping room, or a bathroom attached to either, carbon monoxide detection shall be installed in the bedroom or sleeping room. Where carbon monoxide detection is not installed in bedrooms or sleeping rooms, carbon monoxide detection shall be installed outside of each separate sleeping area in close proximity to bedrooms or sleeping rooms for either of the following conditions:

1. The dwelling unit or sleeping unit has a communicating opening to an attached, enclosed garage.
2. A direct carbon monoxide source is located in the dwelling unit or sleeping unit outside of bedrooms or sleeping rooms.

**915.2.4.2 Forced-indirect carbon monoxide sources.** Bedrooms or sleeping rooms in dwelling units or sleeping units that are exposed to a forced-indirect carbon monoxide source shall be provided with carbon monoxide detection in accordance with Section 915.2.4.1 or Section 915.2.3.

**915.3 Location of detection devices.** Carbon monoxide detection devices shall be installed in accordance with manufacturer's instructions in a location that avoids dead air spaces, turbulent air spaces, fresh air returns, open windows, and obstructions that would inhibit accumulation of carbon monoxide at the detection location. Carbon monoxide detection in air ducts or plenums shall not be permitted as an alternative to required detection locations.

**915.4 Permissible detection devices.** Carbon monoxide detection shall be provided by a carbon monoxide detection system complying with Section 915.4.2 unless carbon monoxide alarms are permitted by Sections 915.4.1.

**915.4.1 Carbon monoxide alarms.** Carbon monoxide alarms complying with Sections 915.4.1.1 through 915.4.1.3 shall be permitted in lieu of a carbon monoxide detection system in both of the following:

1. Dwelling units and sleeping units.
2. Locations other than dwelling units or sleeping units, where approved, provided that the manufacturer's instructions do not prohibit installation in locations other

than dwelling units or sleeping units and that the alarm signal for any carbon monoxide alarm installed in a normally unoccupied location is annunciated by an audible and visual signal in an approved location.

**915.4.1.1 Power source.** In buildings with a wired power source, carbon monoxide alarms shall receive their primary power from a permanent connection to building wiring, with no disconnecting means other than for overcurrent protection, and shall be provided with a battery backup. In buildings without a wired power source, carbon monoxide alarms shall be battery powered.

**Exception:** For existing buildings not previously required to have carbon monoxide alarms permanently connected to a wired power source, existing battery-powered and plug-in with battery backup carbon monoxide alarms shall be permitted to remain in service. When replaced, replacement with battery-powered and plug-in with battery backup carbon monoxide alarms shall be permitted.

**915.4.1.2 Listings.** Carbon monoxide alarms shall be listed in accordance with UL 2034. Combination carbon monoxide/smoke alarms shall also be listed in accordance with UL 217.

**915.4.1.3 Interconnection.** Where more than one carbon monoxide alarm is installed, actuation of any alarm shall cause all of the alarms to signal an alarm condition.

**915.4.2 Carbon monoxide detection systems.** Carbon monoxide detection systems shall be installed in accordance with NFPA 72.

**915.4.2.1 Fire alarm system integration.** Where a building fire alarm system or combination fire alarm system, as defined in NFPA 72, is installed, carbon monoxide detection shall be provided by connecting carbon monoxide detectors to the fire alarm system. Where a building fire alarm system or a combination fire alarm system is not installed, carbon monoxide detection shall be provided by connecting carbon monoxide detectors to a carbon monoxide detection system complying with NFPA 72.

**915.4.2.2 Listings.** Carbon monoxide detectors shall be listed in accordance with UL 2075. Combination carbon monoxide/smoke detectors shall be listed in accordance with UL 268 and UL 2075.

**915.4.2.3 Alarm notification.** For other than Group E Occupancies, activation of a carbon monoxide detector shall initiate alarm notification in accordance with any of the following:

1. An audible and visible alarm notification throughout the building and at the control unit.
2. Where specified in an approved fire safety plan, an audible and visible alarm in the signaling zone where the carbon monoxide has been detected and other signaling zones specified in the fire safety plan, and at the control unit.

3. Where a sounder base is provided for each detector, an audible alarm at the activated carbon monoxide detector and an audible and visible alarm at the control unit.

For Group E Occupancies having an occupant load of 30 or less, alarm notification shall be provided in an on-site location staffed by school personnel or in accordance with the notification requirements for other occupancies. For Group E occupancies having an occupant load of more than 30, an audible and visible alarm shall be provided in an on-site location staffed by school personnel.

**915.5 Maintenance.** Carbon monoxide alarms and carbon monoxide detection systems shall be maintained in accordance with NFPA 72 and the manufacturer's instructions. Carbon monoxide alarms and carbon monoxide detectors that become inoperable or begin producing end-of-life signals shall be replaced.

*(Reason: The final version of the 2024 edition text for Section 915 that was approved fell short of clearly conveying requirements. Furthermore, the adopted code text seems to require a level of protection for some occupancies that is excessive and for other occupancies insufficient. This wording matches the approved changes in the 2027 IFC)*

**\*\*Section 1006.2.1 change exception 3 to read as follows;**

**Section 1006.2.1 Egress based on occupant load and common path of egress travel distance.**

3. Unoccupied rooftop mechanical rooms and penthouses are not required to comply with the common path of egress travel distance measurement.

*(Reason: Add "rooftop" to Exception No. 3 to clarify that only such mechanical rooms located on the roof maybe exempted.)*

**\*\*\*Table 1010.2.4; amend Table - Manual Bolts, Automatic Flush Bolts and Constant Latching Bolts on the Inactive Leaf of A pair of Doors; to add Group M and A occupancies as follows:**

**Add Group M to Line item #1 in Table 1010.2.4:** Group B, F, M or S occupancies with occupant load less than 50. [Remainder unchanged]

**Add Group A and M to Line item #2 in Table 1010.2.4:** Group A, B, F, M or S occupancies where the building is equipped... [Remainder unchanged]

*(Reason: 2024 Code revised this information into Table format. It is historically common in our region to see the 2nd leaf locked, when that leaf is not part of the required egress door clear width, such as in a typical Group M. Table 1010.2.4 line item 2 was expanded to Group A due to it being a similar situation for Group B restaurants. When the required door width capacity is met by a single door, the inactive leaf shall be allowed to be locked since it is not required for egress. This intent of the amendment remains unchanged from previous cycle(s) and has been adjusted to reflect the new format in the 2024 IBC.)*

**\*\*Section 1020.2 Construction; add new exception 6 as follows:**

6. In unsprinklered group B occupancies, corridor walls and ceilings need not be of fire-resistive construction within a single tenant space when the space is equipped with approved automatic smoke-detection within the corridor. The actuation of any detector must activate self-annunciating alarms audible in all areas within the corridor. Smoke detectors must be connected to an approved automatic fire alarm system where such system is provided.

*(Reason: Similar concept was previously in UBC. This scenario occurs primarily in existing, non-sprinklered buildings, which under current IBC would be required to have a fire resistance rated corridor. New exception provides a cost-effective solution for single tenant space in lieu of the base IBC requirement to retrofit a fire sprinkler system throughout the building.)*

**\*\*Section 1030.1.1.1 Spaces under grandstands and bleachers; delete this section.**

*(Reason: Unenforceable.)*

**\*\*Section 1101.1 Scope; add exception to Section 1101.1 as follows:**

**Exception:** Components of projects regulated by and registered with Architectural Barriers Division of Texas Department of Licensing and Regulation shall be deemed to be in compliance with the requirements of this chapter.

*(Reason: To accommodate buildings regulated under state law. Further clarified in 2018 to mean components that are specifically addressed by TDLR shall be exempt.)*

**\*\*Section 2702.5; added to read as follows:**

**Section 2702.5 Designated Critical Operations Areas (DCOA):** In areas within a facility or site requiring continuous operation for the purpose of public safety, emergency management, national security or business continuity, the power systems shall comply with NFPA 70 Article 708.

*(Reason: Identifying these areas of critical operations in the building code ensures designers are advised of the requirements outlined in the National Electrical Code which defines specific Critical Operations Power System (COPS) requirements.)*

**\*\*Section 2901.1; add a sentence to read as follows:**

**[P] 2901.1 Scope.** {existing text to remain} The provisions of this Chapter are meant to work in coordination with the provisions of Chapter 4 of the International Plumbing Code. Should any conflicts arise between the two chapters, the Building Official shall determine which provision applies.

*(Reason: Gives building official discretion.)*

**\*\*Section 2902.1; add a second paragraph to read as follows:**

In other than E Occupancies, the minimum number of fixtures in Table 2902.1 may be lowered, if requested in writing, by the applicant stating reasons for a reduced number and approved by the Building Official.

*(Reason: To allow flexibility for designer to consider specific occupancy needs.)*

**\*\*Table 2902.1; add footnote g to read as follows:**

*g. Drinking fountains are not required in M Occupancies with an occupant load of 100 or less, B Occupancies with an occupant load of 25 or less, and for dining and/or drinking establishments.*

*(Reason: To allow flexibility for designer to consider specific occupancy needs.)*

**\*\*Add Section 2902.1.4 to read as follows:**

**2902.1.4 Additional fixtures for food preparation facilities.** In addition to the fixtures required in this Chapter, all food service facilities shall be provided with additional fixtures set out in this section.

**2902.1.4.1 Hand washing lavatory.** At least one hand washing lavatory shall be provided for use by employees that is accessible from food preparation, food dispensing and ware washing areas. Additional hand washing lavatories may be required based on convenience of use by employees.

**2902.1.4.2 Service sink.** In new or remodeled food service establishments, at least one service sink or one floor sink shall be provided so that it is conveniently located for the cleaning of mops or similar wet floor cleaning tool and for the disposal of mop water and similar liquid waste. The location of the service sink(s) and/or mop sink(s) shall be approved by the <Jurisdiction's> health department.

*(Reason: Coordinates Health law requirements with code language for consistent regional practice.)*

**\*\*\*Section 3002.1 Hoistway Enclosure Protection required. Add pointer and exception as follows:**

A hoistway for elevators, dumbwaiters and other vertical-access devices shall comply with Sections 712 and 713. Where the hoistway is required to be enclosed, it shall be constructed as a shaft enclosure in accordance with 713. Refer to 712.1.10 for elevators in parking garages.

Exception:

1. Elevators completely located within atriums shall not require hoistway enclosure protection.

*(Reason: Provides specific Code recognition for elevators completely within atriums. Amendment needed since specific Code language does not currently exist for elevators within atriums. A pointer has been added to the exception for enclosure requirements in parking garages.)*

**\*\*\*3004.2.1 Enclosure. Add text to read as follows:**

Escalator floor openings shall be enclosed with shaft enclosures complying with Section 712 and 713.

*(Reason: Section 3004.2.1 does not acknowledge the multitude of ways in which IBC allows escalators in vertical openings. The addition of 712 to the base requirement sends the users to the escalator opening protection requirements contained in Section 712.)*

**\*\*\*Section 3005.4 Machine rooms, control rooms, machinery spaces and control spaces; Delete existing IBC exceptions and replace with two new NCTCOG exceptions as follows:**

**Exceptions:**

1. For other than FSAE and occupant evacuation elevators, elevator machine rooms, control rooms, machinery spaces and control spaces completely located within atriums shall not require enclosure protection.
2. For other than FSAE and occupant evacuation elevators, elevator machine rooms, control rooms, machinery spaces and control spaces in open or enclosed parking garages that serve only the parking garage, shall not require enclosure protection.

*(Reason: This amendment eliminates the IBC Exceptions to Section 3005.4 and replaces them with new NCTCOG exceptions. The fire rating of these enclosures is permitted to be omitted by the above added NCTCOG exceptions where allowed by other provisions of the code such as in atriums and parking structures. Added “for other than FSAE and occupant evacuation elevators” in recognition of these special elevators requiring maximum code required protection and for consistency with IBC existing language in the deleted exceptions. See companion change to eliminate fire sprinklers to eliminate the need for shunt trip system.)*

**\*\*\*Section 3005.5: Add a new subsection to Section 3005.5.1 as follows:**

**3005.5.1 Fire Protection in Machine rooms, control rooms, machinery spaces and control spaces.**

**3005.5.1.1 Automatic sprinkler system.** The building shall be equipped throughout with an automatic sprinkler system in accordance with Section 903.3.1.1, except as otherwise permitted by Section 903.3.1.1.1 and as prohibited by Section 3005.5.1.1.1.

**3005.5.1.1.1 Prohibited locations.** Automatic sprinklers shall not be installed in machine rooms, elevator machinery spaces, control rooms, control spaces and elevator hoistways.

**3005.5.1.1.2 Automatic Sprinkler system monitoring.** The automatic sprinkler system shall have a sprinkler control valve supervisory switch and water-flow initiating device provided for each floor that is monitored by the building's fire alarm system.

**3005.5.1.2 Water protection.** An approved method to prevent water from infiltrating into the hoistway enclosure from the operation of the automatic sprinkler system outside the elevator lobby shall be provided.

**3005.5.1.3 Omission of Shunt trip.** Means for elevator shutdown in accordance with Section 3005.5 shall not be installed.

*(Reason: Firefighter and public safety. This amendment eliminates the shunt trip requirement of the International Building Code Section 3005.5 for the purpose of elevator passenger and firefighter safety. The new section above is intended to be identical to Sections 3007.2, 3007.3, and 3007.4 for Fire Service Access Elevators and Sections 3008.2, 3008.3 and 3008.4 for Occupant Evacuation Elevators except where amended by the NCTOG Amendments.)*

**\*\*Section 3005; add Section 3005.7 as follows:**

**3005.7 Storage.** Storage shall not be allowed within the elevator machine room, control room, machinery spaces and or control spaces. Provide approved signage at each entry to the above listed locations stating: "No Storage Allowed".

*(Reason: Reinforces the need to maintain space clean and free of combustibles. See companion change to eliminate fire sprinklers therein, Section 3005.5.1.)*

**Option A**

**\*\*Section 3006.2, Hoistway opening protection required; Insert new text in item 5 as follows:**

5. The building is a high rise and the elevator hoistway is more than 75 feet (22 860 mm) in height. The height of the hoistway shall be measured from the lowest floor at or above grade to the highest floors served by the hoistway.

**Option B**

**\*\*Section 3006.2, Hoistway opening protection required; Revise text in item 5 as follows:**

5. The building is a high rise and the elevator hoistway is more than ~~75 feet (22 860 mm)~~ 55 feet (16 764 mm) in height. The height of the hoistway shall be measured from the lowest floor at or above grade to the highest floors served by the hoistway.

*(Reason: 2024 IBC text does not address hoistways that are greater than 75'-0" in height that are both below grade and above grade but not located above the high-rise classification nor does the IBC address hoistways wholly located above grade such as those that serve sky lobbies.)*

**\*\*Section 3007.3 and Section 3008.3: Revise text by deleting "enclosed" as follows:**

**3007.3 Water Protection.** Water from the operation of an automatic sprinkler system outside the elevator ~~enclosed~~ lobby shall be prevented from infiltrating into the hoistway enclosure in accordance with an approved method.

**3008.3 Water Protection.** Water from the operation of an automatic sprinkler system outside the elevator ~~enclosed~~-lobby shall be prevented from infiltrating into the hoistway enclosure in accordance with an approved method.

*(Reason: The lobbies for FSAE and or OEE elevators may be open (i.e., at ground level), or may not require a lobby enclosure on those upper floors with secondary cab entry doors opening into a nonrequired FSAE or OEE lobby. Regardless of whether or not the lobby is enclosed, the objective is to preclude fire sprinkler water from entering into the hoistway serving FSAE and OEE elevators. The deletion of "enclosed" clarifies the original intent of this provision and is consistent with ICC interpretations. Added the word "elevator" to clarify which type of lobbies.)*

**End**



## AGENDA ITEM

TO: Mayor and City Council

SUBJECT: Issuance of the Corporation's hotel revenue bonds

MEETING DATE: June 23, 2026

DEPARTMENT: Administration

---

### ITEM SUMMARY:

Consider and act on Resolution No. 2026-113R approving a resolution of the Roanoke Convention Center Hotel Local Development Corporation authorizing the issuance of the Corporation's hotel revenue bonds; approving execution and delivery of all agreements and documents related to the development, construction and operation of the convention center hotel project; and enacting other provisions relating to the subject.

### INFORMATION:

### STAFF RECOMMENDATION:

### SPECIAL CONSIDERATION:

### FINANCIAL CONSIDERATION:

### ATTACHMENTS:

1. RES NO 2026-113R CITY Approval of RCCH LGC Bond Res - ver 1

**RESOLUTION NO. 2026-113R**

**RESOLUTION APPROVING A RESOLUTION OF THE ROANOKE CONVENTION CENTER HOTEL LOCAL DEVELOPMENT CORPORATION AUTHORIZING THE ISSUANCE OF THE CORPORATION'S HOTEL REVENUE BONDS; APPROVING EXECUTION AND DELIVERY OF ALL AGREEMENTS AND DOCUMENTS RELATED TO THE DEVELOPMENT, CONSTRUCTION AND OPERATION OF THE CONVENTION CENTER HOTEL PROJECT; AND ENACTING OTHER PROVISIONS RELATING TO THE SUBJECT**

**WHEREAS**, Roanoke Convention Center Hotel Local Development Corporation (the "Corporation") is a nonprofit local government corporation created by the City of Roanoke, Texas (the "City") and existing under Subchapter D of Chapter 431, Texas Transportation Code, as amended ("Act"); and

**WHEREAS**, there has been presented to this City Council a resolution (the "Bond Resolution") adopted by the Board of Directors of the Corporation authorizing the issuance and sale of the Corporation's hotel revenue bonds within certain parameters set forth in the Bond Resolution (the "Bonds"), for the purposes of acquiring, constructing, furnishing and equipping a full service convention center hotel (the "Hotel"), providing for the funding of various accounts and funds, paying capitalized interest, paying costs of issuance of the Bonds and other purposes permitted by law (the "Bond Project"); and

**WHEREAS**, in connection with the development, financing and construction of convention center and meeting facilities, related infrastructure and parking facilities connected to and integrated with the Hotel (the "City Facilities" and together with the Hotel, the "Project"), the City has authorized the issuance of certificates of obligation and general obligation bonds; and

**WHEREAS**, this City Council finds and determines that it is necessary and appropriate to approve the Bond Resolution for the purposes herein provided; and

**WHEREAS**, it is hereby officially found and determined that the meeting at which this Resolution was passed, was open to the public and public notice of the time, place, and purpose of said meeting was given, all as required by Chapter 551, Texas Government Code.

**THEREFORE, BE IT RESOLVED BY THE CITY COUNCIL OF THE CITY OF ROANOKE, TEXAS, THAT:**

**SECTION 1.**

The recitals set forth in the preamble hereof are incorporated herein and shall have the same force and effect as if set forth in this Section. The Bond Resolution, attached hereto as **Exhibit A**, is hereby approved and the issuance of the Bonds by the Corporation within the parameters set forth in the Bond Resolution, for the purpose of financing the Bond Project, is hereby approved; and said Bond Resolution, the Bonds and the expenditure of funds of the Corporation in connection therewith are hereby approved.

## **SECTION 2.**

The Mayor, City Manager, Director of Finance and any other officer or employee of the City, and each of them, shall be and they are hereby expressly authorized, empowered and directed from time to time and at any time to negotiate the terms of and execute, acknowledge and deliver on behalf of the City all such instruments, contracts, agreements and certificates whether or not herein mentioned, as may be necessary or desirable in order to carry out the terms and provisions of this Resolution and the development, financing, construction, operation and management of the Project.

## **SECTION 3.**

All prior action by the City in connection with the development, financing, construction, operation and management of the Project is hereby ratified, approved and confirmed.

## **SECTION 4.**

This Resolution shall become effective immediately upon adoption.

[Execution Page Follows]

**APPROVED AND ADOPTED JUNE 23, 2026.**

---

Lindsay Rawlinson  
City Secretary

---

Carl E. Gierisch, Jr. Mayor

(CITY SEAL)

RESOLUTION APPROVING A RESOLUTION OF THE ROANOKE CONVENTION CENTER  
HOTEL LOCAL DEVELOPMENT CORPORATION

Exhibit A  
Corporation Bond Resolution



## AGENDA ITEM

TO: Mayor and City Council

SUBJECT: Certificates of Obligation-Parking

MEETING DATE: June 23, 2026

DEPARTMENT: Administration

---

### ITEM SUMMARY:

Consider and act on Ordinance No. 2026-137 authorizing the issuance of certificates of obligation; delegating the authority to certain city officials to execute certain documents relating to the sale of the certificates; approving and authorizing an official statement and instruments and procedures relating to said certificates; and enacting other provisions relating to the subject.

### INFORMATION:

### STAFF RECOMMENDATION:

### SPECIAL CONSIDERATION:

### FINANCIAL CONSIDERATION:

### ATTACHMENTS:

1. Ordinance No. 2026-137 - CO 2026 - Parking

CERTIFICATE FOR ORDINANCE

THE STATE OF TEXAS §  
TARRANT AND DENTON COUNTIES §  
CITY OF ROANOKE, TEXAS §

We, the undersigned officers of the City Council of the City of Roanoke, Texas hereby certify as follows:

1. The City Council convened in a regular meeting on June 23, 2026, at the regular designated meeting place, and the roll was called of the duly constituted officers and members of the City Council, to wit:

Scooter Gierisch, Mayor  
Brian Darby  
David Thompson  
John Pullen

Holly Gray, Mayor Pro Tem  
David Brundage  
Ernie Adams

and all of the above persons were present except \_\_\_\_\_, thus constituting a quorum. Whereupon, among other business the following was transacted at the Meeting: a written Ordinance entitled

ORDINANCE AUTHORIZING THE ISSUANCE OF CERTIFICATES OF OBLIGATION; DELEGATING THE AUTHORITY TO CERTAIN CITY OFFICIALS TO EXECUTE CERTAIN DOCUMENTS RELATING TO THE SALE OF THE CERTIFICATES; APPROVING AND AUTHORIZING AN OFFICIAL STATEMENT AND INSTRUMENTS AND PROCEDURES RELATING TO SAID CERTIFICATES; AND ENACTING OTHER PROVISIONS RELATING TO THE SUBJECT

was duly introduced for the consideration of the City Council. It was then duly moved and seconded that the Order be passed; and, after due discussion, the motion, carrying with it the passage of the Order, prevailed and carried, with all members of the City Council shown present above voting "Aye," except as noted below:

NAYS: \_\_\_\_\_ ABSTENTIONS: \_\_\_\_\_

2. A true, full, and correct copy of the Ordinance passed at the Meeting described in the above and foregoing paragraph is attached to and follows this Certificate; the Ordinance has been duly recorded in the Council's minutes of the Meeting; the above and foregoing paragraph is a true, full, and correct excerpt from the City Council's minutes of the Meeting pertaining to the passage of the Ordinance; the persons named in the above and foregoing paragraph are the duly chosen, qualified, and acting officers and members of the City Council as indicated therein; that each of the officers and members of the City Council was duly and sufficiently notified officially and personally, in advance, of the time, place, and purpose of the Meeting, and that the Ordinance would be introduced and considered for passage at the Meeting, and each of the officers and members consented, in advance, to the holding of the Meeting for such purpose; and that the Meeting was open to the public, and public notice of the time, place, and purpose of the Meeting was given all as required by the Texas Government Code, Chapter 551.

3. The Mayor of the City Council has approved and hereby approves the Ordinance; and the Mayor and the City Secretary of the City hereby declare that their signing of this certificate shall constitute the signing of the attached and following copy of said Ordinance for all purposes.

SIGNED AND SEALED ON JUNE 23, 2026

---

Lindsay Rawlinson  
City Secretary

---

Carl E. Gierisch, Jr.  
Mayor

(CITY SEAL)

ORDINANCE NO. 2026-137

ORDINANCE AUTHORIZING THE ISSUANCE OF CERTIFICATES OF OBLIGATION; DELEGATING THE AUTHORITY TO CERTAIN CITY OFFICIALS TO EXECUTE CERTAIN DOCUMENTS RELATING TO THE SALE OF THE CERTIFICATES; APPROVING AND AUTHORIZING AN OFFICIAL STATEMENT AND INSTRUMENTS AND PROCEDURES RELATING TO SAID CERTIFICATES; AND ENACTING OTHER PROVISIONS RELATING TO THE SUBJECT

WHEREAS, the City Council of the City of Roanoke (the "City") passed a resolution authorizing and directing notice of its intention to issue the Certificates of Obligation herein authorized, to be published in a newspaper as required by Section 271.049 of the Texas Local Government Code;

WHEREAS, said notice was published in The Fort Worth Star Telegram, a newspaper of the type described in Section 2051.044, Texas Government Code, as required by said Section 271.049 of the Texas Local Government Code;

WHEREAS, said notice provided that the ordinance authorizing the Certificates of Obligation may authorize an authorized officer of the City to effect the sale and delivery of the Certificates of Obligation on a date or dates subsequent to the adoption of the ordinance;

WHEREAS, no petition, signed by at least 5% of the qualified electors of said City as permitted by said Section 271.049 of the Texas Local Government Code protesting the issuance of such Certificates of Obligation, has been filed;

WHEREAS, the City is an "Issuer" within the meaning of Section 1371.001(4)(P), Texas Government Code, having (i) a principal amount of at least \$100 million in outstanding long-term indebtedness, in long-term indebtedness proposed to be issued, or a combination of outstanding or proposed long-term indebtedness and (ii) some amount of long-term indebtedness outstanding or proposed to be issued that is rated in one of the four highest rating categories for long-term debt instruments by a nationally recognized rating agency for municipal securities, without regard to the effect of any credit agreement or other form of credit enhancement entered into in connection with the obligation;

WHEREAS, the Certificates of Obligation hereinafter authorized are to be issued and delivered pursuant to Subchapter C of Chapter 271 of the Texas Local Government Code and Chapter 1371, Texas Government Code and the City's Home Rule Charter;

WHEREAS, during the preceding three years, the City has not submitted a bond proposition to authorize the issuance of bonds for the same purpose for which the Certificates of Obligation are hereby being issued and which proposition was disapproved by voters; and

WHEREAS, it is officially found, determined, and declared that the meeting at which this Ordinance has been adopted was open to the public and public notice of the time, place and subject matter of the public business to be considered and acted upon at said meeting, including this Ordinance, was given, all as required by the applicable provisions of Texas Government Code, Chapter 551;

THEREFORE, BE IT ORDAINED BY THE CITY COUNCIL OF THE CITY OF ROANOKE, TEXAS:

**Section 1. DEFINITIONS; AUTHORIZATION OF CERTIFICATES OF OBLIGATION.**

(a) *Definitions.* Terms not otherwise defined herein shall have the following meanings.

(i) The term "Authorized Denomination" shall mean a denomination of \$5,000 of principal amount of a Certificate or any integral multiple thereof.

(ii) The term "Business Day" means any day other than a Saturday, Sunday, a legal holiday, or a day on which banking institutions in the City are, authorized by law or executive order to close.

(iii) The term "Certificates" and "Certificates of Obligation" shall mean the Certificates authorized to be issued and delivered by this Ordinance.

(iv) The term "Financial Obligation" means a: (a) debt obligation; (b) derivative instrument entered into in connection with, or pledged as security or a source of payment for, an existing or planned debt obligation; or (c) a guarantee of the foregoing (a) and (b). The term Financial Obligation does not include any municipal securities as to which a final official statement has been provided to the MSRB consistent with the Rule.

(v) The term "MSRB" means the Municipal Securities Rulemaking Board.

(vi) The term "Pricing Certificate" means a certificate of the Pricing Officer setting forth the terms of sale of the Certificates including the method of sale, principal amount, maturity dates, interest payment dates, dated date, interest rates, yields, redemption provisions, and other matters related to the sale of the Certificates.

(vii) The term "Pricing Officer" means the Mayor, the City Manager and the Chief Financial Officer of the City (each the "Pricing Officer") each of whom is independently authorized to finalize the terms of sale of the Certificates by execution of the Pricing Certificate.

(viii) The term "Purchaser" means (i) if the Certificates are sold by negotiated sale, the underwriter or underwriting syndicate selected by the Pricing Officer, or (ii) if the Certificates are sold by competitive sale by soliciting public bids, the underwriter or underwriting syndicate awarded the Certificates by the Pricing Officer.

(ix) The term "Rule" means SEC Rule 15c2-12 (17 C.F.R. § 240.15C2-12), as amended from time to time.

(x) The term "SEC" means the United States Securities and Exchange Commission.

(xi) The term "Surplus Revenues" shall mean those revenues from the operation of the City's waterworks and sewer system that remain after the payment of all maintenance and operation expenses thereof, and all debt service, reserve and other requirements in connection with all of the Issuer's revenue obligations (now or hereafter outstanding) that are secured by a lien on all or any part of the net revenues of the Issuer's waterworks and sewer system..

(b) The Certificates are hereby authorized to be issued and delivered in the principal amount not to exceed \$25,000,000 for paying all or a portion of the City's contractual obligations incurred in connection with the following public projects: (i) constructing and/or acquiring structured parking for public use and (ii) legal, fiscal and engineering fees in connection with such projects.

**Section 2. DELEGATION TO PRICING OFFICER.**

(a) As authorized by Section 1371.053, Texas Government Code, each Pricing Officer is hereby authorized to act individually and severally on behalf of the City in selling and delivering the Certificates, carrying out the other procedures specified in this Ordinance, including, determining the date of the Certificates, any additional or different designation or title by which the Certificates shall be known, whether the Certificate shall be sold and delivered in one or more series and the date and sale and delivery of each such series, the price at which the Certificates will be sold, the years in which the Certificates will mature, the principal amount to mature in each of such years, the rate of interest to be borne by each such maturity, the interest payment and record dates, the price and terms upon and at which the Certificates shall be subject to redemption prior to maturity at the option of the City, as well as any mandatory sinking fund redemption provisions, and all other matters relating to the issuance, sale, and delivery of the Certificates and obtaining municipal insurance for all or any portion of the Certificates and providing for the terms and provisions thereof applicable to the Certificates, all of which shall be specified in the Pricing Certificate.

(b) No series of Certificates shall be issued pursuant to this Ordinance unless each of the following parameters are satisfied as specified in the Pricing Certificate:

(i) the aggregate principal amount of the Certificates shall not exceed \$25,000,000;

(ii) the true interest cost of the Certificates shall not exceed 6.00% per annum;

(iii) the final maturity of the Certificates shall not exceed August 15, 2055;

(iv) the delegation made hereby shall expire if not exercised by the Pricing Officer on or prior ninety days from the date of adoption of this Ordinance; and

(v) on or prior to delivery, the Certificates shall be rated by a nationally recognized rating agency for municipal securities in one of the four highest categories for long-term obligations.

(c) Each Certificate issued pursuant to this Ordinance shall be designated: "CITY OF ROANOKE, TEXAS, COMBINATION TAX AND SURPLUS REVENUE CERTIFICATES OF OBLIGATION, SERIES 2026."

(d) In establishing the aggregate principal amount of the Certificates, the Pricing Officer shall establish an amount that, when combined with premium used for purposes other than the payment of costs of issuance, does not exceed the amount authorized in subsection (b) hereof, which shall be sufficient in amount to provide for the purposes for which the Certificates are authorized and to pay costs of issuing the Certificates. The Certificates shall be sold with and subject to such terms as set forth in the Pricing Certificate.

(e) The Certificates may be sold by public offering (either through a negotiated or competitive offering) and the Pricing Certificate shall so state, and the Pricing Certificate may conform this Ordinance to such method of sale, including the provisions hereof that pertain to the undertaking of the Issuer in accordance with the Rule.

(f) The City Council hereby determines that the delegation of the authority to the Pricing Officer to approve the final terms of the Certificates as set forth in this Ordinance is, and the decisions made by the Pricing Officer pursuant to such delegated authority and incorporated into the Pricing Certificate are required to be, in the Issuer's best interests, and the Pricing Officer is hereby authorized to make and include in the Pricing Certificate a finding to that effect.

### **Section 3. CHARACTERISTICS OF THE CERTIFICATES.**

(a) The City shall keep or cause to be kept at the corporate trust office in Dallas, Texas (the "Designated Trust Office") of U.S. Bank Trust Company, National Association (the "Paying Agent/Registrar"), books or records for the registration and transfer of the Certificates (the "Registration Books"), and the City hereby appoints the Paying Agent/Registrar as its registrar and transfer agent to keep such books or records and make such transfers and registrations under such reasonable regulations as the City and the Paying Agent/Registrar may prescribe; and the Paying Agent/Registrar shall make such transfers and registrations as herein provided. It shall be the duty of the Paying Agent/Registrar to obtain from the registered owner and record in the Registration Books the address of the registered owner of each Certificate to which payments with respect to the Certificates shall be mailed, as herein provided. The City or its designee shall have the right to inspect the Registration Books during regular business hours of the Paying Agent/Registrar at its Designated Trust Office, but otherwise the Paying Agent/Registrar shall keep the Registration Books confidential and, unless otherwise required by law, shall not permit their inspection by any other entity. Registration of each Certificate may be transferred in the Registration Books only upon presentation and surrender thereof to the Paying Agent/Registrar at its Designated Trust Office for transfer of registration and cancellation, together with proper written instruments of assignment, in form and with guarantee of signatures satisfactory to the Paying Agent/Registrar, evidencing the assignment of such Certificate, or any portion thereof in any Authorized Denomination, to the assignee or assignees thereof, and the right of such assignee or assignees to have such Certificate or any such portion thereof registered in the name of such assignee or assignees. Upon the assignment and transfer of any Certificate or any portion thereof, a new substitute certificate or certificates shall be issued in exchange therefor in the manner herein provided.

(b) The entity in whose name any Certificate shall be registered in the Registration Books at any time shall be treated as the absolute owner thereof for all purposes of this Ordinance, whether or not such Certificate shall be overdue, and the City and the Paying Agent/Registrar shall not be affected by any notice to the contrary; and payment of, or on account of, the principal of, premium, if any, and interest on any such certificate shall be made only to such registered owner. All such payments shall be valid and effectual to satisfy and discharge the liability upon such certificate to the extent of the sum or sums so paid.

(c) The City hereby further appoints the Paying Agent/Registrar to act as the paying agent for paying the principal of and interest on the Certificates, and to act as its agent to exchange or replace Certificates, all as provided in this Ordinance. The Paying Agent/Registrar shall keep proper records of all payments made by the City and the Paying Agent/Registrar with respect to the Certificates, and of all exchanges thereof, and all replacements thereof, as provided in this Ordinance.

(d) Each Certificate may be exchanged for fully registered certificates in the manner set forth herein. Each Certificate issued and delivered pursuant to this Ordinance may, upon surrender thereof at the Designated Trust Office of the Paying Agent/Registrar, together with a written request therefor duly executed by the registered owner or the assignee or assignees thereof, or its or their duly authorized attorneys or representatives, with guarantee of signatures satisfactory to the Paying Agent/Registrar, at the option of the registered owner or such assignee or assignees, as appropriate, be exchanged for fully registered Certificates, without interest coupons, in the form prescribed in the FORM OF CERTIFICATE, in an Authorized Denomination (subject to the requirement hereinafter stated that each substitute Certificate shall have a single stated maturity date), as requested in writing by such registered owner or such assignee or assignees, in an aggregate principal amount equal to the principal amount of any Certificate or Certificates so surrendered, and payable to the appropriate registered owner, assignee, or assignees, as the case may be. If any Certificate or portion thereof is assigned and transferred, each Certificate issued in exchange therefor shall have the same principal maturity date and bear interest at the same rate as the Certificate for which it is being exchanged. Each substitute Certificate shall bear a letter and/or number to

distinguish it from each other Certificate. The Paying Agent/Registrar shall exchange or replace Certificates as provided herein, and each fully registered Certificate or Certificates delivered in exchange for or replacement of any Certificate or portion thereof as permitted or required by any provision of this Ordinance shall constitute one of the Certificates for all purposes of this Ordinance, and may again be exchanged or replaced. It is specifically provided, however, that any Certificate delivered in exchange for or replacement of another Certificate prior to the first scheduled interest payment date on the Certificates (as stated on the face thereof) shall be dated the same date as such Certificate, but each substitute Certificate so delivered on or after such first scheduled interest payment date shall be dated as of the interest payment date preceding the date on which such substitute Certificate is delivered, unless such substitute Certificate is delivered on an interest payment date, in which case it shall be dated as of such date of delivery; provided, however, that if at the time of delivery of any substitute Certificate the interest on the Certificate for which it is being exchanged has not been paid, then such substitute Certificate shall be dated as of the date to which such interest has been paid in full. On each substitute Certificate issued in exchange for or replacement of any Certificate or Certificates issued under this Ordinance there shall be printed thereon a Paying Agent/Registrar's Authentication Certificate, in the form hereinafter set forth in the FORM OF CERTIFICATE (the "Authentication Certificate"). An authorized representative of the Paying Agent/Registrar shall, before the delivery of any such substitute Certificate, date such substitute Certificate in the manner set forth above, and manually sign and date the Authentication Certificate, and no such substitute Certificate shall be deemed to be issued or outstanding unless the Authentication Certificate is so executed. The Paying Agent/Registrar promptly shall cancel all Certificates surrendered for exchange or replacement. No additional ordinances, orders, or resolutions need be passed or adopted by the City Council or any other body or person so as to accomplish the foregoing exchange or replacement of any Certificates or portion thereof, and the Paying Agent/Registrar shall provide for the printing, execution, and delivery of the substitute Certificate in the manner prescribed herein. Pursuant to Chapter 1206, Texas Government Code, the duty of exchange or replacement of any Certificates as aforesaid is hereby imposed upon the Paying Agent/Registrar, and, upon the execution of Authentication Certificate, the exchanged or replaced Certificate shall be valid, incontestable, and enforceable in the same manner and with the same effect as the Certificates which originally were delivered pursuant to this Ordinance, approved by the Attorney General, and registered by the Comptroller of Public Accounts. Neither the City nor the Paying Agent/Registrar shall be required to transfer or exchange any Certificate so selected for redemption, in whole or in part, within 45 calendar days of the date fixed for redemption; provided, however, such limitation of transfer shall not be applicable to an exchange by the registered owner of the uncalled principal of a Certificate.

(e) All Certificates issued in exchange or replacement of any other Certificate or portion thereof, (i) shall be issued in fully registered form, without interest coupons, with the principal of and interest on such Certificates to be payable only to the registered owners thereof, (ii) may be redeemed prior to their scheduled maturities, (iii) may be transferred and assigned, (iv) may be exchanged for other Certificates, (v) shall have the characteristics, (vi) shall be signed and sealed, and (vii) the principal of and interest on the Certificates shall be payable, all as provided, and in the manner required or indicated, in the FORM OF CERTIFICATE.

(f) The City shall pay the Paying Agent/Registrar's reasonable and customary fees and charges for making transfers of Certificates, but the registered owner of any Certificate requesting such transfer shall pay any taxes or other governmental charges required to be paid with respect thereto. The registered owner of any Certificates requesting any exchange shall pay the Paying Agent/Registrar's reasonable and standard or customary fees and charges for exchanging any such certificate or portion thereof, together with any taxes or governmental charges required to be paid with respect thereto, all as a condition precedent to the exercise of such privilege of exchange, except, however, that in the case of the exchange of an assigned and transferred Certificate or Certificates or any portion or portions thereof in an Authorized Denomination, as provided in this Ordinance, such fees and charges will be paid by the City. In addition, the City hereby

covenants with the registered owners of the Certificates that it will (i) pay the reasonable and standard or customary fees and charges of the Paying Agent/Registrar for its services with respect to the payment of the principal of and interest on Certificates, when due, and (ii) pay the fees and charges of the Paying Agent/Registrar for services with respect to the transfer or registration of Certificates solely to the extent above provided, and with respect to the exchange of Certificates solely to the extent above provided.

(g) The City covenants with the registered owners of the Certificates that at all times while the Certificates are outstanding the City will provide a competent and legally qualified bank, trust company, financial institution, or other agency to act as and perform the services of Paying Agent/Registrar for the Certificates under this Ordinance, and that the Paying Agent/Registrar will be one entity. The City reserves the right to, and may, at its option, change the Paying Agent/Registrar upon not less than sixty days written notice to the Paying Agent/Registrar. In the event that the entity at any time acting as Paying Agent/Registrar (or its successor by merger, acquisition, or other method) should resign or otherwise cease to act as such, the City covenants that it will promptly appoint a competent and legally qualified national or state banking institution which shall be a corporation organized and doing business under the laws of the United States of America or of any state, authorized under such laws to exercise trust powers, subject to supervision or examination by federal or state authority, and whose qualifications substantially are similar to the previous Paying Agent/Registrar to act as Paying Agent/Registrar under this Ordinance. Upon any change in the Paying Agent/Registrar, the previous Paying Agent/Registrar promptly shall transfer and deliver the Registration Books (or a copy thereof), along with all other pertinent books and records relating to the Certificates, to the new Paying Agent/Registrar designated and appointed by the City. Upon any change in the Paying Agent/Registrar, the City promptly will cause a written notice thereof to be sent by the new Paying Agent/Registrar to each registered owner of the Certificates, by United States mail, first-class postage prepaid, which notice also shall give the address of the new Paying Agent/Registrar. By accepting the position and performing as such, each Paying Agent/Registrar shall be deemed to have agreed to the provisions of this Ordinance, and a certified copy of this Ordinance shall be delivered to each Paying Agent/Registrar.

**Section 4. FORM OF CERTIFICATES.** The form of the Certificates, including the form of the Authentication Certificate, the form of Assignment and the form of Registration Certificate of the Comptroller of Public Accounts of the State of Texas to be attached to the Certificates initially issued and delivered pursuant to this Ordinance, shall be in substantially the form as set forth in **Exhibit A** to this Ordinance. The Certificates shall numbered consecutively from R-1 upward, with the Initial Certificate being numbered T-1, with such appropriate variations, omissions, or insertions as are permitted or required by this Ordinance and with the FORM OF CERTIFICATE to be modified pursuant to, and completed with information set forth in the Pricing Certificate. The FORM OF CERTIFICATE as it appears in **Exhibit A** shall be completed, amended and modified by Bond Counsel to incorporate the information set forth in the Pricing Certificate but it is not required for the FORM OF CERTIFICATE to reproduced as an exhibit to the Pricing Certificate. The printer of the Certificates is hereby authorized to print on the Certificates (i) the form of bond counsel's opinion relating to the Certificates, and (ii) an appropriate statement of insurance furnished by a municipal bond insurance company providing municipal bond insurance, if any, covering all or any part of the Certificates.

#### **Section 5. REDEMPTION PROVISIONS.**

(a) *Optional Redemption.* The Certificates may be subject to optional redemption prior to maturity on the dates and at the redemption prices as set forth in the Pricing Certificate. The Pricing Officer is hereby delegated to make such modifications to the provisions of this section in the Pricing Certificate as are necessary to complete the sale and delivery of the Certificates.

(b) *Notice of Redemption.* At least thirty days prior to the date fixed for any redemption of Certificates, or portions thereof, prior to maturity, the Issuer shall cause written notice of such redemption to be sent by United States mail, first class, postage prepaid, to each Registered Owner of a Certificate to be redeemed, in whole or in part, at the address of the Registered Owner appearing on the registration books of the Paying Agent/Registrar at the close of business on the business day next preceding the date of mailing of such notice. All notices of redemption so mailed shall be conclusively presumed to have been duly given irrespective of whether received by the Registered Owner.

(c) *Firm Banking and Financial Arrangements.* By the date fixed for any prior redemption, due provision shall be made with the Paying Agent/Registrar for the payment of the required redemption price for the Certificates or portions thereof that are to be redeemed. If written notice of redemption is mailed and if due provision for such payment is made, all as provided above, the Certificates or portions thereof that are to be redeemed shall automatically be treated as redeemed prior to their scheduled maturities, and they shall not bear interest after the date fixed for redemption, and they shall not be regarded as being outstanding except for the right of the Registered Owner to receive the redemption price from the Paying Agent/Registrar out of the funds provided for such payment. If a portion of any Certificate shall be redeemed, a substitute Certificate having the same maturity date, bearing interest at the same rate, in an Authorized Denomination, at the written request of the Registered Owner, and in an aggregate principal amount equal to the unredeemed portion thereof, will be issued to the Registered Owner upon the surrender thereof for cancellation, at the expense of the Issuer.

(d) *Selection of Certificates for Redemption.* If less than all Certificates of the same maturity are to be redeemed on a redemption date, the Paying Agent/Registrar shall randomly select by lot the Certificates within such maturity to be redeemed.

(e) *Conditional Notice of Redemption.* With respect to any optional redemption of the Certificates, unless certain prerequisites to such redemption required by this Order have been met and moneys sufficient to pay the principal of and premium, if any, and interest on the Certificates to be redeemed shall have been received by the Paying Agent/Registrar prior to the giving of such notice of redemption, such notice shall state that said redemption may, at the option of the Issuer, be conditional upon the satisfaction of such prerequisites and receipt of such moneys by the Paying Agent/Registrar on or prior to the date fixed for such redemption, or upon any prerequisite set forth in such notice of redemption. If a conditional notice of redemption is given and such prerequisites to the redemption and sufficient moneys are not received, such notice shall be of no force and effect, the Issuer shall not redeem such Certificates and the Paying Agent/Registrar shall give notice, in the manner in which the notice of redemption was given, to the effect that the Certificates have not been redeemed.

## **Section 6. LEVY OF TAX; INTEREST AND SINKING FUND; REVENUE PLEDGE.**

(a) A special fund or account to be designated the "Series 2026 CO Interest and Sinking Fund" (the "Interest and Sinking Fund") is hereby created and shall be established and maintained by the City. The Interest and Sinking Fund shall be kept separate and apart from all other funds and accounts of the City, and shall be used only for paying the interest on and principal of the Certificates. All ad valorem taxes levied and collected for and on account of the Certificates shall be deposited, as collected, to the credit of the respective Interest and Sinking Fund. During each year while any of the Certificates are outstanding and unpaid, the governing body of the City shall compute and ascertain the rate and amount of ad valorem tax, based on the latest approved tax rolls of the City, with full allowances being made for tax delinquencies and the cost of tax collections, which will be sufficient to raise and produce the money required to pay the interest on the Certificates as such interest comes due, and to provide a sinking fund to pay the principal (including mandatory sinking fund redemption payments, if any) of the Certificates as such principal matures or comes due through operation of the mandatory sinking fund redemption, if any, but never less

than 2% of the original amount of the Certificates as a sinking fund each year. The rate and amount of ad valorem tax is hereby ordered to be levied against all taxable property in the City for each year while any of the Certificates is outstanding and unpaid, and the ad valorem tax shall be assessed and collected each such year and deposited to the credit of the Interest and Sinking Fund. Ad valorem taxes necessary to pay the interest on and principal of the Certificates, as such interest comes due and such principal matures, are hereby pledged for such payment, within the limit prescribed by law.

(b) The Certificates are additionally secured by and shall be payable from a pledge of Surplus Revenues. The Surplus Revenues are pledged by the City pursuant to authority of Chapter 1502, Texas Government Code, specifically Section 1502.058 thereof. The City shall promptly deposit the Surplus Revenues upon their receipt to the credit of the Interest and Sinking Fund created pursuant to Section 6, to pay the principal and interest on the Certificates. If Surplus Revenues or any other lawfully available revenues, income or resources of the City are deposited or budgeted to be deposited in the Interest and Sinking Fund in advance of the time when ad valorem taxes are scheduled to be levied for any year, then the amount of taxes that otherwise would have been required to be levied pursuant to Section 6 may be reduced to the extent and by the amount of the Surplus Revenues or other lawfully available revenues, income or resources then on deposit or budgeted to be deposited to the credit of the Interest and Sinking Fund.

(c) Application of Chapter 1208, Government Code. Chapter 1208, Texas Government Code, applies to the issuance of the Certificates and the pledge of ad valorem taxes and the Surplus Revenues granted by the City under this section, and such pledge is therefore valid, effective, and perfected. If Texas law is amended at any time while the Certificates are outstanding and unpaid such that the pledge of the ad valorem taxes and Surplus Revenues granted by the City is to be subject to the filing requirements of Chapter 9, Texas Business & Commerce Code, then in order to preserve to the Registered Owners of the Certificates the perfection of the security interest in said pledge, the City agrees to take such measures as it determines are reasonable and necessary under Texas law to comply with the applicable provisions of Chapter 9, Texas Business & Commerce Code and enable a filing to perfect the security interest in said pledge to occur.

(d) The City shall do any and all things necessary to accomplish the transfer of monies to the Interest and Sinking Fund of this issue in ample time to pay such items of principal and interest due on the Certificates.

(e) The Interest and Sinking Fund created by this Ordinance shall be secured in the manner and to the fullest extent permitted or required by law for the security of public funds, and such Interest and Sinking Fund shall be used only for the purposes and in the manner permitted or required by this Ordinance.

(f) In order to pay any debt service coming due on the Certificates prior to receipt of the taxes levied to pay such debt service, there is hereby appropriated from current funds on hand, which are hereby certified to be on hand and available for such purpose, an amount sufficient to pay such debt service, and such amount shall be used for no other purpose.

**Section 7. DAMAGED, MUTILATED, LOST, STOLEN, OR DESTROYED CERTIFICATES.**

(a) *Replacement Certificates.* In the event any outstanding Certificate is damaged, mutilated, lost, stolen, or destroyed, the Paying Agent/Registrar shall cause to be printed, executed, and delivered, a new Certificate of the same principal amount, maturity, and interest rate, as the damaged, mutilated, lost, stolen, or destroyed Certificate, in replacement for such Certificate in the manner hereinafter provided.

(b) *Application for Replacement Certificates.* Application for replacement of damaged, mutilated, lost, stolen, or destroyed Certificates shall be made by the registered owner thereof to the Paying Agent/Registrar. In every case of loss, theft, or destruction of a Certificate, the registered owner applying for a replacement Certificate shall furnish to the City and to the Paying Agent/Registrar such security or indemnity as may be required by them to save each of them harmless from any loss or damage with respect thereto. Also, in every case of loss, theft, or destruction of a Certificate, the registered owner shall furnish to the City and to the Paying Agent/Registrar evidence to their satisfaction of the loss, theft, or destruction of such Certificate, as the case may be. In every case of damage or mutilation of a Certificate, the registered owner shall surrender to the Paying Agent/Registrar for cancellation the Certificate so damaged or mutilated.

(c) *No Default Occurred.* Notwithstanding the foregoing provisions of this Section, in the event any such Certificate shall have matured, and no default has occurred which is then continuing in the payment of the principal of, redemption premium, if any, or interest on the Certificate, the City may authorize the payment of the same (without surrender thereof except in the case of a damaged or mutilated Certificate) instead of issuing a replacement certificate, provided security or indemnity is furnished as above provided in this Section.

(d) *Charge for Issuing Replacement Certificates.* Prior to the issuance of any replacement Certificate, the Paying Agent/Registrar shall charge the registered owner of such Certificate with all legal, printing, and other expenses in connection therewith. Every replacement Certificate issued pursuant to the provisions of this Section by virtue of the fact that any Certificate is lost, stolen, or destroyed shall constitute a contractual obligation of the City whether or not the lost, stolen, or destroyed Certificate shall be found at any time, or be enforceable by anyone, and shall be entitled to all the benefits of this Ordinance equally and proportionately with any and all other Certificates duly issued under this Ordinance.

(e) *Authority for Issuing Replacement Certificates.* In accordance with Section 1201.067, Texas Government Code, this Section of this Ordinance shall constitute authority for the issuance of any such replacement Certificate without necessity of further action by the City or any other body or person, and the duty of the replacement of such Certificates is hereby authorized and imposed upon the Paying Agent/Registrar, and the Paying Agent/Registrar shall authenticate and deliver such Certificates in the form and manner and with the effect, as provided in Section 4(d) of this Ordinance for Certificates issued in conversion and exchange of other Certificates.

## **Section 8. FEDERAL INCOME TAX MATTERS.**

(a) *Covenants.* The Issuer covenants to take any action necessary to assure, or refrain from any action which would adversely affect, the treatment of the Certificates as obligations described in section 103 of the Code, the interest on which is not includable in the "gross income" of the Registered Owner for purposes of federal income taxation. In furtherance thereof, the Issuer covenants as follows:

(i) to take any action to assure that no more than 10 percent of the proceeds of the Certificates or the projects financed therewith (less amounts deposited to a reserve fund, if any) are used for any "private business use," as defined in section 141(b)(6) of the Code or, if more than 10 percent of the proceeds or the projects financed therewith are so used, such amounts, whether or not received by the Issuer, with respect to such private business use, do not, under the terms of this Resolution or any underlying arrangement, directly or indirectly, secure or provide for the payment of more than 10 percent of the debt service on the Certificates, in contravention of section 141(b)(2) of the Code;

(ii) to take any action to assure that in the event that the "private business use" described in subsection (a)(i) hereof exceeds 5 percent of the proceeds of the Certificates or the projects

financed therewith (less amounts deposited into a reserve fund, if any) then the amount in excess of 5 percent is used for a "private business use" which is "related" and not "disproportionate," within the meaning of section 141(b)(3) of the Code, to the governmental use;

(iii) to take any action to assure that no amount which is greater than the lesser of \$5,000,000, or 5 percent of the proceeds of the Certificates (less amounts deposited into a reserve fund, if any) is directly or indirectly used to finance loans to persons, other than state or local governmental units, in contravention of section 141(c) of the Code;

(iv) to refrain from taking any action which would otherwise result in the Certificates being treated as "private activity bonds" within the meaning of section 141(b) of the Code;

(v) to refrain from taking any action that would result in the Certificates being "federally guaranteed" within the meaning of section 149(b) of the Code;

(vi) to refrain from using any portion of the proceeds of the Certificates, directly or indirectly, to acquire or to replace funds which were used, directly or indirectly, to acquire investment property (as defined in section 148(b)(2) of the Code) which produces a materially higher yield over the term of the Certificates, other than investment property acquired with:

(A) proceeds of the Certificates invested for a reasonable temporary period of 3 years or less or, in the case of a refunding bond, for a period of 90 days or less until such proceeds are needed for the purpose for which the bonds are issued,

(B) amounts invested in a bona fide debt service fund, within the meaning of section 1.148 1(b) of the Treasury Regulations, and

(C) amounts deposited in any reasonably required reserve or replacement fund to the extent such amounts do not exceed 10 percent of the proceeds of the Certificates;

(vii) to otherwise restrict the use of the proceeds of the Certificates or amounts treated as proceeds of the Certificates, as may be necessary, so that the Certificates do not otherwise contravene the requirements of section 148 of the Code (relating to arbitrage); and

(viii) to pay to the United States of America at least once during each five-year period (beginning on the date of delivery of the Certificates) an amount that is at least equal to 90 percent of the "Excess Earnings" (within the meaning of section 148(f) of the Code) and to pay to the United States of America, not later than 60 days after the Certificates have been paid in full, 100 percent of the amount then required to be paid as a result of Excess Earnings under section 148(f) of the Code.

(b) *Rebate Fund*. In order to facilitate compliance with subsection (a)(viii), a "Rebate Fund" is hereby established by the Issuer for the sole benefit of the United States of America, and such fund shall not be subject to the claim of any other person, including without limitation the Registered Owners. The Rebate Fund is established for the additional purpose of compliance with section 148 of the Code.

(c) *Proceeds*. The Issuer understands that the term "proceeds" includes "disposition proceeds" as defined in the Treasury Regulations and, in the case of refunding bonds, transferred proceeds (if any) and proceeds of refunded obligations expended prior to the date of issuance of the Certificates. It is the understanding of the Issuer that the covenants contained herein are intended to assure compliance with the Code and any regulations or rulings promulgated by the U.S. Department of the Treasury pursuant thereto. In the event that regulations or rulings are hereafter promulgated which modify or expand provisions of the

Code, as applicable to the Certificates, the Issuer will not be required to comply with any covenant contained herein to the extent that such failure to comply, in the opinion of nationally recognized bond counsel, will not adversely affect the exemption from federal income taxation of interest on the Certificates under section 103 of the Code. In the event that regulations or rulings are hereafter promulgated which impose additional requirements which are applicable to the Certificates, the Issuer agrees to comply with the additional requirements to the extent necessary, in the opinion of nationally recognized bond counsel, to preserve the exemption from federal income taxation of interest on the Certificates under section 103 of the Code. In furtherance of such intention, the Issuer hereby authorizes and directs the City Manager or Chief Financial Officer to execute any documents, certificates or reports required by the Code and to make such elections, on behalf of the Issuer, which may be permitted by the Code as are consistent with the purpose for the issuance of the Certificates. This section shall apply only to the Certificates.

**Section 9. DISPOSITION OF PROJECT.** The Issuer covenants that the property financed with the proceeds of the Certificates will not be sold or otherwise disposed in a transaction resulting in the receipt by the Issuer of cash or other compensation, unless the Issuer obtains an opinion of nationally recognized bond counsel that such sale or other disposition will not adversely affect the tax-exempt status of such bonds. For purposes of the foregoing, the portion of the property comprising personal property and disposed in the ordinary course shall not be treated as a transaction resulting in the receipt of cash or other compensation. For purposes hereof, the Issuer shall not be obligated to comply with this covenant if it obtains an opinion that such failure to comply will not adversely affect the excludability for federal income tax purposes from gross income of the interest. This section shall apply only to the Certificates

**Section 10. ALLOCATION OF, AND LIMITATION ON, EXPENDITURES FOR THE PROJECT.** The Issuer covenants to account for the expenditure of sale proceeds and investment earnings to be used for the construction and acquisition of the Project on its books and records by allocating proceeds to expenditures within 18 months of the later of the date that (1) the expenditure is made, or (2) the Project is completed. The foregoing notwithstanding, the Issuer shall not expend sale proceeds or investment earnings thereon more than 60 days after the earlier of (1) the fifth anniversary of the delivery of the Certificates, or (2) the date the Certificates are retired, unless the Issuer obtains an opinion of nationally-recognized bond counsel that such expenditure will not adversely affect the status, for federal income tax purposes, of the Certificates or the interest thereon. For purposes hereof, the Issuer shall not be obligated to comply with this covenant if it obtains an opinion that such failure to comply will not adversely affect the excludability for federal income tax purposes from gross income of the interest. This section shall apply only to the Certificates

**Section 11. Reserved.**

**Section 12. CUSTODY, APPROVAL, AND REGISTRATION OF CERTIFICATES.** The City Manager or the Chief Financial Officer of the City is hereby authorized to have control of the Certificates initially issued and delivered hereunder and all necessary records and proceedings pertaining to the Certificates pending their delivery and their investigation, examination, and approval by the Attorney General of the State of Texas, and their registration by the Comptroller of Public Accounts of the State of Texas. Upon registration of the Certificates said Comptroller of Public Accounts (or a deputy designated in writing to act for said Comptroller) shall manually sign the Comptroller's Registration Certificate attached to such Certificates, and the seal of said Comptroller shall be impressed, or placed in facsimile, on such certificate. The Certificates thus registered shall remain in the custody of the Chief Financial Officer (or the designee thereof) until delivered to the Purchaser (as defined in Section 16 of this Ordinance).

**Section 13. DTC REGISTRATION.** The Certificates initially shall be issued and delivered in such manner that no physical distribution of the Certificates will be made to the public, and The Depository Trust Company ("DTC"), New York, New York, initially will act as depository for the Certificates. DTC

has represented that it is a limited purpose trust company incorporated under the laws of the State of New York, a member of the Federal Reserve System, a "clearing corporation" within the meaning of the New York Uniform Commercial Code, and a "clearing agency" registered under Section 17A of the Securities Exchange Act of 1934, as amended, and the City accepts, but in no way verifies, such representations. The Certificates initially authorized by this Ordinance shall be delivered to and registered in the name of CEDE & CO., the nominee of DTC. It is expected that DTC will hold the Certificates on behalf of the Purchaser and its participants. So long as each Certificate is registered in the name of CEDE & CO., the Paying Agent/Registrar shall treat and deal with DTC the same in all respects as if it were the actual and beneficial owner thereof. It is expected that DTC will maintain a book-entry system which will identify ownership of the Certificates in Authorized Denominations, with transfers of ownership being effected on the records of DTC and its participants pursuant to rules and regulations established by them, and that the Certificates initially deposited with DTC shall be immobilized and not be further exchanged for substitute Certificates except as hereinafter provided. The City is not responsible or liable for any functions of DTC, will not be responsible for paying any fees or charges with respect to its services, will not be responsible or liable for maintaining, supervising, or reviewing the records of DTC or its participants, or protecting any interests or rights of the beneficial owners of the Certificates. It shall be the duty of the DTC Participants, as defined in the Official Statement herein approved, to make all arrangements with DTC to establish this book-entry system, the beneficial ownership of the Certificates, and the method of paying the fees and charges of DTC. The City does not represent, nor does it in any way covenant that the initial book-entry system established with DTC will be maintained in the future. Notwithstanding the initial establishment of the foregoing book-entry system with DTC, if for any reason any of the originally delivered Certificates is duly filed with the Paying Agent/Registrar with proper request for transfer and substitution, as provided for in this Ordinance, substitute Certificates will be duly delivered as provided in this Ordinance, and there will be no assurance or representation that any book-entry system will be maintained for such Certificates. In connection with the initial establishment of the foregoing book-entry system with DTC, the City heretofore has executed a "Blanket Letter of Representations" prepared by DTC in order to implement the book-entry system described above.

**Section 14. CONTINUING DISCLOSURE OBLIGATION PURSUANT TO RULE 15C2-12 (17 C.F.R. § 240.15C2-12).**

(a) *Annual Reports.*

(i) The City will provide certain updated financial information and operating data to the MSRB on an annual basis in an electronic format that is prescribed by the MSRB and available via the Electronic Municipal Market Access System ("EMMA") at [www.emma.msrb.org](http://www.emma.msrb.org). The information to be updated includes all quantitative financial information and operating data with respect to the City of the general type included in the Official Statement under Tables numbered [-] and in Appendix B. The City will update and provide the information in Tables [-] within six months after the end of each fiscal year ending in and after 2026. The City will additionally provide audited financial statements when and if available, and in any event, within 12 months after the end of each fiscal year ending in or after 2026. If the audit of such financial statements is not complete within 12 months after any such fiscal year end, then the City will file unaudited financial statements within such 12-month period and audited financial statements for the applicable fiscal year, when and if the audit report on such statements becomes available. Any such financial statements will be prepared in accordance with the accounting principles described in Appendix B of the Official Statement or such other accounting principles as the City may be required to employ from time to time pursuant to State law or regulation.

(ii) The financial information and operating data to be provided may be set forth in full in one or more documents or may be included by specific reference to any document available to the

public on the MSRB's Internet Web site or filed with the SEC, as permitted by the Rule. If the City changes its fiscal year, it will notify the MSRB of the change (and of the date of the new fiscal year end) prior to the next date by which the City otherwise would be required to provide financial information and operating data pursuant to this Section. The financial information and operating data to be provided pursuant to this Section may be set forth in full in one or more documents or may be included by specific reference to any document that is available to the public on the MSRB's internet website or filed with the SEC. All documents provided to the MSRB pursuant to this Section shall be accompanied by identifying information as prescribed by the MSRB.

(b) *Event Notices.* The City shall notify the MSRB in an electronic format as prescribed by the MSRB, in a timely manner (but not in excess of ten Business Days after the occurrence of the event) of any of the following events with respect to the Certificates:

1. Principal and interest payment delinquencies;
2. Non-payment related defaults, if material;
3. Unscheduled draws on debt service reserves reflecting financial difficulties;
4. Unscheduled draws on credit enhancements reflecting financial difficulties;
5. Substitution of credit or liquidity providers, or their failure to perform;
6. Adverse tax opinions or the issuance by the Internal Revenue Service of proposed or final determinations of taxability, Notices of Proposed Issue (IRS Form 5701-TEB) or other material notices or determinations with respect to the tax status of the Certificates, or other material events affecting the tax status of the Certificates;
7. Modifications to rights of Certificateholders, if material;
8. Certificate calls, if material, and tender offers;
9. Defeasances;
10. Release, substitution, or sale of property securing repayment of the Certificates, if material;
11. Rating changes;
12. Bankruptcy, insolvency, receivership or similar event of an obligated person (which is considered to occur when any of the following occur: the appointment of a receiver, fiscal agent, or similar officer for the City in a proceeding under the United States Bankruptcy Code or in any other proceeding under state or federal law in which a court or governmental authority has assumed jurisdiction over substantially all of the assets or business of the City, or if such jurisdiction has been assumed by leaving the existing governing body and officials or officers in possession but subject to the supervision and orders of a court or governmental authority, or the entry of an order confirming a plan of reorganization, arrangement, or liquidation by a court or governmental authority having supervision or jurisdiction over substantially all of the assets or business of the City);
13. The consummation of a merger, consolidation, or acquisition involving an obligated person or the sale of all or substantially all of the assets of the obligated person, other than in the ordinary course of business, the entry into a definitive agreement to undertake such an action or the

termination of a definitive agreement relating to any such actions, other than pursuant to its terms, if material;

14. Appointment of a successor or additional trustee or the change of name of a trustee, if material;

15. Incurrence of a Financial Obligation of the City, if material, or agreement to covenants, events of default, remedies, priority rights, or other similar terms of a Financial Obligation of the City, any of which affect Bondholders, if material; and

16. Default, event of acceleration, termination event, modification of terms, or other similar events under the terms of a Financial Obligation of the City, any of which reflect financial difficulties.

The City shall notify the MSRB, in a timely manner, of any failure by the City to provide financial information or operating data in accordance with this Section by the time required by such subsection.

*(c) Limitations, Disclaimers, and Amendments.*

(i) The City shall be obligated to observe and perform the covenants specified in this Section for so long as, but only for so long as, the City remains an "obligated person" with respect to the Certificates within the meaning of the Rule, except that the City in any event will give notice of any deposit made in accordance with this Ordinance or applicable law that causes Certificates no longer to be outstanding.

(ii) The provisions of this Section are for the sole benefit of the registered owners and beneficial owners of the Certificates, and nothing in this Section, express or implied, shall give any benefit or any legal or equitable right, remedy, or claim hereunder to any other person. The City undertakes to provide only the financial information, operating data, financial statements, and notices which it has expressly agreed to provide pursuant to this Section and does not hereby undertake to provide any other information that may be relevant or material to a complete presentation of the City's financial results, condition, or prospects or hereby undertake to update any information provided in accordance with this Section or otherwise, except as expressly provided herein. The City does not make any representation or warranty concerning such information or its usefulness to a decision to invest in or sell Certificates at any future date.

(iii) UNDER NO CIRCUMSTANCE SHALL THE CITY BE LIABLE TO THE REGISTERED OWNER OR BENEFICIAL OWNER OF ANY CERTIFICATE OR ANY OTHER PERSON, IN CONTRACT OR TORT, FOR DAMAGES RESULTING IN WHOLE OR IN PART FROM ANY BREACH BY THE CITY, WHETHER NEGLIGENT OR WITHOUT FAULT ON ITS PART, OF ANY COVENANT SPECIFIED IN THIS SECTION, BUT EVERY RIGHT AND REMEDY OF ANY SUCH PERSON, IN CONTRACT OR TORT, FOR OR ON ACCOUNT OF ANY SUCH BREACH SHALL BE LIMITED TO AN ACTION FOR MANDAMUS OR SPECIFIC PERFORMANCE.

(iv) No default by the City in observing or performing its obligations under this Section shall comprise a breach of or default under this Ordinance for purposes of any other provision of this Ordinance. Nothing in this Section is intended or shall act to disclaim, waive, or otherwise limit the duties of the City under federal and state securities laws.

(v) Should the Rule be amended to obligate the City to make filings with or provide notices to entities other than the MSRB, the City hereby agrees to undertake such obligation with respect

to the Certificates in accordance with the Rule as amended. The provisions of this Section may be amended by the City from time to time to adapt to changed circumstances that arise from a change in legal requirements, a change in law, or a change in the identity, nature, status, or type of operations of the City, but only if (1) the provisions of this Section, as so amended, would have permitted an underwriter to purchase or sell Certificates in the primary offering of the Certificates in compliance with the Rule, taking into account any amendments or interpretations of the Rule since such offering as well as such changed circumstances and (2) either (a) the registered owners of a majority in aggregate principal amount (or any greater amount required by any other provision of this Ordinance that authorizes such an amendment) of the outstanding Certificates consent to such amendment or (b) a person that is unaffiliated with the City (such as nationally recognized bond counsel) determined that such amendment will not materially impair the interest of the registered owners and beneficial owners of the Certificates. If the City so amends the provisions of this Section, it shall include with any amended financial information or operating data next provided in accordance with subsection (b) of this Section an explanation, in narrative form, of the reason for the amendment and of the impact of any change in the type of financial information or operating data so provided. The City may also amend or repeal the provisions of this continuing disclosure agreement if the SEC amends or repeals the applicable provision of the Rule or a court of final jurisdiction enters judgment that such provisions of the Rule are invalid, but only if and to the extent that the provisions of this sentence would not prevent an underwriter from lawfully purchasing or selling Certificates in the primary offering of the Certificates.

#### **Section 15. DEFEASANCE.**

(a) *Deemed Paid.* Any Certificate and the interest thereon shall be deemed to be paid, retired and no longer outstanding (a "Defeased Certificate") within the meaning of this Ordinance, except to the extent provided in subsection (e) of this Section, when payment of the principal of such Certificate, plus interest thereon to the due date (whether such due date be by reason of maturity or otherwise) either (i) shall have been made or caused to be made in accordance with the terms thereof, or (ii) shall have been provided for on or before such due date by irrevocably depositing with or making available to the Paying Agent/Registrar in accordance with an escrow agreement or other instrument (the "Future Escrow Agreement") for such payment (1) lawful money of the United States of America sufficient to make such payment or (2) Defeasance Securities that mature as to principal and interest in such amounts and at such times as will insure the availability, without reinvestment, of sufficient money to provide for such payment, and when proper arrangements have been made by the City with the Paying Agent/Registrar for the payment of its services until all Defeased Certificates shall have become due and payable. At such time as a Certificate shall be deemed to be a Defeased Certificate hereunder, as aforesaid, such Certificate and the interest thereon shall no longer be secured by, payable from, or entitled to the benefits of, the ad valorem taxes herein levied and pledged or the pledge of Surplus Revenues as provided in this Ordinance, and such principal and interest shall be payable solely from such money or Defeasance Securities.

(b) *Investments.* Any moneys so deposited with the Paying Agent/Registrar may at the written direction of the City be invested in Defeasance Securities, maturing in the amounts and times as hereinbefore set forth, and all income from such Defeasance Securities received by the Paying Agent/Registrar that is not required for the payment of the Certificates and interest thereon, with respect to which such money has been so deposited, shall be turned over to the City, or deposited as directed in writing by the City. Any Future Escrow Agreement pursuant to which the money and/or Defeasance Securities are held for the payment of Defeased Certificates may contain provisions permitting the investment or reinvestment of such moneys in Defeasance Securities or the substitution of other Defeasance Securities upon the satisfaction of the requirements specified in subsection (a)(i) or (ii) above. All income from such Defeasance Securities received by the Paying Agent/Registrar which is not required for the payment of the

Defeased Securities, with respect to which such money has been so deposited, shall be remitted to the City or deposited as directed in writing by the City.

(c) *Selection of Defeased Certificates.* In the event that the City elects to defease less than all of the principal amount of Certificates of a maturity, the Paying Agent/Registrar shall select, or cause to be selected, such amount of Certificates by such random method as it deems fair and appropriate.

(d) *Defeasance Securities.* The term "Defeasance Securities" means (i) direct, noncallable obligations of the United States of America, including obligations that are unconditionally guaranteed by the United States of America, (ii) noncallable obligations of an agency or instrumentality of the United States, including obligations that are unconditionally guaranteed or insured by the agency or instrumentality and that, on the date the governing body of the City adopts or approves the proceedings authorizing the issuance of refunding bonds, are rated as to investment quality by a nationally recognized investment rating firm not less than AAA or its equivalent; (iii) noncallable obligations of a state or an agency or a county, municipality, or other political subdivision of a state that have been refunded and that, on the date the governing body of the City adopts or approves the proceedings authorizing the issuance of refunding bonds, are rated as to investment quality by a nationally recognized investment rating firm not less than AAA or its equivalent and (iv) any securities and obligations now or hereafter authorized by State law that are eligible to refund, retire or otherwise discharge obligations such as the Certificates.

(e) The Pricing Officer is authorized to modify the categories of Defeasance Securities that are eligible to defease the Certificates.

(f) *Continuing Duty of Paying Agent/Registrar.* Until all Certificates defeased under this Section of this Ordinance shall become due and payable, the Paying Agent/Registrar for such Certificates shall perform the services of Paying Agent/Registrar for such Certificates the same as if they had not been defeased, and the City shall make proper arrangements to provide and pay for such services.

#### **Section 16. SALE OF CERTIFICATES; OFFICIAL STATEMENT.**

(a) The Certificates may be sold by public offering (either through a negotiated or competitive offering) and the terms and provisions of which are to be determined by the Pricing Officer in accordance with Section 2 hereof, and in which the purchasers of the Certificates are designated. The Certificates may be sold pursuant to a purchase agreement or notice of sale and bidding instructions (collectively, the "Purchase Agreement") which the Pricing Officer is hereby authorized to execute and deliver and in which the Purchaser of the Certificates shall be designated. The Certificates shall initially be registered in the name of the Purchaser thereof as set forth in the Pricing Certificate.

(b) The City hereby deems final and approves the form and content of the draft preliminary official statement relating to the Certificates and any addenda, supplement or amendment thereto, and approves the distribution of such preliminary official statement in the reoffering of the Certificates by the Purchaser in final form, with such changes therein or additions thereto as the Pricing Officer executing the same may deem advisable. The Pricing Officer is hereby authorized, in the name and on behalf of the City, to approve, distribute, and deliver a final preliminary official statement and a final official statement relating to the Certificates to be used by the Purchaser in the marketing of the Certificates.

(c) The Pricing Officer is authorized, in connection with effecting the sale of the Certificates, to obtain from a municipal bond insurance company so designated in the Pricing Certificate (the "Insurer") a municipal bond insurance policy (the "Insurance Policy") in support of the Certificates. To that end, should the Pricing Officer exercise such authority and commit the City to obtain a municipal bond insurance policy, for so long as the Insurance Policy is in effect, the requirements of the Insurer relating to the issuance of the Insurance Policy are incorporated by reference into this Ordinance and made a part hereof for all

purposes, notwithstanding any other provision of this Ordinance to the contrary. The Pricing Officer shall have the authority to execute any documents to effect the issuance of the Insurance Policy by the Insurer.

(d) The Mayor and Mayor Pro Tem, the City Manager, the Chief Financial Officer and City Secretary, shall be and they are hereby expressly authorized, empowered and directed from time to time and at any time to do and perform all such acts and things and to execute, acknowledge and deliver in the name and under the corporate seal and on behalf of the City a Paying Agent/Registrar Agreement, in the form presented at the meeting at which this Ordinance is adopted, with the Paying Agent/Registrar and all other instruments, whether or not herein mentioned, as may be necessary or desirable in order to carry out the terms and provisions of this Ordinance, the Certificates, the sale of the Certificates, the Purchase Agreement and the Official Statement. In case any officer whose signature shall appear on any Certificate shall cease to be such officer before the delivery of such Certificate, such signature shall nevertheless be valid and sufficient for all purposes the same as if such officer had remained in office until such delivery.

**Section 17. FURTHER PROCEDURES.** The Mayor, the City Secretary, the City Manager, the Chief Financial Officer, shall be and they are hereby expressly authorized, empowered, and directed from time to time and at any time to do and perform all such acts and things and to execute, acknowledge, and deliver in the name and under the corporate seal and on behalf of the City all such instruments, whether or not herein mentioned, as may be necessary or desirable in order to carry out the terms and provisions of this Ordinance, and the sale and delivery of the Certificates and fixing all details in connection therewith. The City Council hereby authorizes the payment of the fee of the Office of the Attorney General of the State of Texas for the examination of the proceedings relating to the issuance of the Certificates, in the amount determined in accordance with the provisions of Section 1202.004, Texas Government Code.

**Section 18. CONSTRUCTION FUND; USE OF PROCEEDS.**

(a) The City hereby creates and establishes and shall maintain on the books of the City a separate fund to be entitled the "Series 2026 Certificates of Obligation Construction Fund" (the "Construction Fund") for use by the City for payment of all lawful costs associated with the acquisition and construction of the projects as provided in Section 1.

(b) The proceeds from the sale of the Certificates shall be deposited, on the date of closing, in the manner described in a letter of instructions prepared by the City or on behalf of the City by the City's financial advisor. The foregoing notwithstanding, any proceeds representing accrued interest on the Certificates shall be deposited to the credit of the Interest and Sinking Fund.

**Section 19. INTEREST EARNINGS.** The interest earnings derived from the investment of proceeds from the sale of the Certificates may be used along with other proceeds for the construction of the permanent improvements set forth in Section 1 hereof for which the Certificates are issued; provided that after completion of such permanent improvements, if any of such interest earnings remain on hand, such interest earnings shall be deposited in the Interest and Sinking Fund. It is further provided, however, that any interest earnings on proceeds which are required to be rebated to the United States of America pursuant to this Ordinance hereof in order to prevent the Certificates from being arbitrage bonds shall be so rebated and not considered as interest earnings for the purposes of this Section.

**Section 20. DEFAULT AND REMEDIES.**

(a) *Events of Default.* Each of the following occurrences or events for the purpose of this Ordinance is hereby declared to be an Event of Default: (i) the failure to make payment of the principal of or interest on any of the Certificates when the same becomes due and payable or (ii) default in the performance or observance of any other covenant, agreement or obligation of the City, the failure to perform which materially, adversely affects the rights of the registered owners of the Certificates, including, but not

limited to, their prospect or ability to be repaid in accordance with this Ordinance, and the continuation thereof for a period of 60 days after notice of such default is given by any registered owner to the City.

(b) *Remedies for Default.* Upon the happening of any Event of Default, then and in every case, any registered owner or an authorized representative thereof, including, but not limited to, a trustee or trustees therefor, may proceed against the City, or any official, officer or employee of the City in their official capacity, for the purpose of protecting and enforcing the rights of the registered owners under this Ordinance, by mandamus or other suit, action or special proceeding in equity or at law, in any court of competent jurisdiction, for any relief permitted by law, including the specific performance of any covenant or agreement contained herein, or thereby to enjoin any act or thing that may be unlawful or in violation of any right of the registered owners hereunder or any combination of such remedies. It is provided that all such proceedings shall be instituted and maintained for the equal benefit of all registered owners of Certificates then outstanding.

(c) *Remedies Not Exclusive.*

(i) No remedy herein conferred or reserved is intended to be exclusive of any other available remedy or remedies, but each and every such remedy shall be cumulative and shall be in addition to every other remedy given hereunder or under the Certificates or now or hereafter existing at law or in equity; provided, however, that notwithstanding any other provision of this Ordinance, the right to accelerate the debt evidenced by the Certificates shall not be available as a remedy under this Ordinance.

(ii) The exercise of any remedy herein conferred or reserved shall not be deemed a waiver of any other available remedy.

(iii) By accepting the delivery of a Certificate authorized under this Ordinance, such registered owner agrees that the certifications required to effectuate any covenants or representations contained in this Ordinance do not and shall never constitute or give rise to a personal or pecuniary liability or charge against the officers, employees or members of the City or the City Council.

(iv) None of the members of the City Council, nor any other official or officer, agent, or employee of the City, shall be charged personally by the registered owners with any liability, or be held personally liable to the registered owners under any term or provision of this Ordinance, or because of any Event of Default or alleged Event of Default under this Ordinance.

## **Section 21. MISCELLANEOUS PROVISIONS.**

(a) *Preamble.* The preamble to this Ordinance is incorporated by reference and made a part hereof for all purposes.

(b) *Titles Not Restrictive.* The titles assigned to the various sections of this Ordinance are for convenience only and shall not be considered restrictive of the subject matter of any section or of any part of this Ordinance.

(c) *Rules of Construction.* The words "herein", "hereof" and "hereunder" and other words of similar import refer to this Ordinance as a whole and not to any particular section or other subdivision. Except where the context otherwise requires, terms defined in this Ordinance to impart the singular number shall be considered to include the plural number and vice versa. References to any named person means that party and its successors and assigns. References to any constitutional, statutory or regulatory provision means such provision as it exists on the date this Ordinance is adopted by the City and any future

amendments thereto or successor provisions thereof. Any reference to "FORM OF CERTIFICATE" shall refer to the form of the Certificates set forth in **Exhibit A** to this Ordinance. Any reference to the payment of principal in this Ordinance shall be deemed to include the payment of any mandatory sinking fund redemption payments as may be described herein.

(d) *Inconsistent Provisions.* All ordinances, orders and resolutions, or parts thereof, which are in conflict or inconsistent with any provision of this Ordinance are hereby repealed and declared to be inapplicable, and the provisions of this Ordinance shall be and remain controlling as to the matters prescribed herein.

(e) *Severability.* If any word, phrase, clause, paragraph, sentence, part, portion, or provision of this Ordinance or the application thereof to any person or circumstance shall be held to be invalid, the remainder of this Ordinance shall nevertheless be valid and the City hereby declares that this Ordinance would have been enacted without such invalid word, phrase, clause, paragraph, sentence, part, portion, or provisions.

(f) *Governing Law.* This Ordinance shall be construed and enforced in accordance with the laws of the State of Texas.

(g) *Open Meeting.* The City officially finds and determines that the meeting at which this Ordinance is adopted was open to the public; and that public notice of the time, place, and purpose of such meeting was given, all as required by Chapter 551, Texas Government Code.

(h) *Immediate Effect.* In accordance with the provisions of Section 1201.028, Texas Government Code, this Ordinance shall be effective immediately upon its adoption by the City Council.

[Remainder of page intentionally left blank.]

EXHIBIT A

FORM OF CERTIFICATE

The form of the Certificates, including the form of Paying Agent/Registrar's Authentication Certificate, the form of Assignment and the form of Registration Certificate of the Comptroller of Public Accounts of the State of Texas to be attached only to the Certificates initially issued and delivered pursuant to this Ordinance, shall be, respectively, substantially as follows, with such appropriate variations, omissions, or insertions as are permitted or required by this Ordinance and with the Certificates to be completed with information set forth in the Pricing Certificate. The Form of Certificate as it appears in this **Exhibit A** shall be completed, amended and modified by Bond Counsel to incorporate the information set forth in the Pricing Certificate but it is not required for the Form of Certificate to reproduced as an exhibit to the Pricing Certificate.

*The "[ - ]" in this section are intentional.*

NO. [R][T]-1  
]

UNITED STATES OF AMERICA  
STATE OF TEXAS  
COUNTIES OF TARRANT AND DENTON

PRINCIPAL  
AMOUNT  
\$ \_\_\_\_\_

CITY OF ROANOKE, TEXAS  
COMBINATION TAX AND SURPLUS REVENUE CERTIFICATE OF OBLIGATION  
SERIES 2026

MATURITY DATE	INTEREST RATE	DELIVERY DATE	CUSIP NO.
_____	_____	[ - ], 2026	_____

REGISTERED OWNER:

PRINCIPAL AMOUNT:

ON THE MATURITY DATE SPECIFIED ABOVE, THE CITY OF ROANOKE, TEXAS, in Tarrant and Denton Counties (the "City"), being a political subdivision of the State of Texas, hereby promises to pay to the Registered Owner specified above or to the registered assignee hereof (either being hereinafter called the "registered owner") the Principal Amount specified above, and to pay interest thereon (calculated on the basis of a 360-day year of twelve 30-day months), from the Delivery Date specified above, to the Maturity Date specified above, or the date of its redemption prior to scheduled maturity, at the interest rate per annum specified above, with said interest payable on [February/August] 15, 202[5], and semiannually on each February 15 and August 15 thereafter until maturity or prior redemption; except that if this Certificate is required to be authenticated and the date of its authentication is later than February 15, 202[5], such interest is payable semiannually on each August 15 and February 15 following such date.

THE PRINCIPAL OF AND INTEREST ON this Certificate are payable in lawful money of the United States of America, without exchange or collection charges. At maturity or redemption prior to maturity, the principal of this Certificate shall be paid to the registered owner hereof upon presentation and surrender of this Certificate at the designated corporate trust office in Dallas, Texas (the "Designated Trust Office") of U.S. BANK TRUST COMPANY, NATIONAL ASSOCIATION, which is the "Paying Agent/Registrar" for this Certificate. The payment of interest on this Certificate shall be made by the Paying Agent/Registrar to the registered owner hereof on each interest payment date by check, dated as of such interest payment date, drawn by the Paying Agent/Registrar on, and payable solely from, funds of the City

required by the ordinance authorizing the issuance of this Certificate (the "Certificate Ordinance") to be on deposit with the Paying Agent/Registrar for such purpose as hereinafter provided; and such check shall be sent by the Paying Agent/Registrar by United States mail, first-class postage prepaid, on each such interest payment date, to the registered owner hereof, at its address as it appeared on the last business day of the month preceding each such date (the "Record Date") on the Registration Books kept by the Paying Agent/Registrar, as hereinafter described. Any accrued interest due at maturity as provided herein shall be paid to the registered owner upon presentation and surrender of this Certificate for payment at the Designated Trust Office of the Paying Agent/Registrar. The City covenants with the registered owner of this Certificate that on or before each principal and interest payment date for this Certificate it will make available to the Paying Agent/Registrar, from the "Interest and Sinking Fund" created by the Certificate Ordinance, the amounts required to provide for the payment, in immediately available funds, of all principal of and interest on the Certificates, when due.

IN THE EVENT OF NON-PAYMENT of interest on a scheduled payment date, and for 30 days thereafter, a new record date for such interest payment (a "Special Record Date") will be established by the Paying Agent/Registrar, if and when funds for the payment of such interest have been received from the City. Notice of the Special Record Date and of the scheduled payment date of the past due interest ("Special Payment Date", which shall be 15 days after the Special Record Date) shall be sent at least five business days prior to the Special Record Date by United States mail, first-class postage prepaid, to the address of each registered owner of a Certificate appearing on the Registration Books kept by the Paying Agent/Registrar at the close of business on the last business day next preceding the date of mailing of such notice.

IF THE DATE for the payment of the principal of or interest on this Certificate shall be a Saturday, Sunday, a legal holiday, or a day on which banking institutions in the city where the Designated Trust Office of the Paying Agent/Registrar is located are authorized by law or executive order to close, then the date for such payment shall be the next succeeding day which is not such a Saturday, Sunday, legal holiday, or day on which banking institutions are authorized to close; and payment on such date shall have the same force and effect as if made on the original date payment was due.

THIS CERTIFICATE is one of a Series of Certificates dated as of [--], 2026, authorized in accordance with the Constitution and laws of the State of Texas in the principal amount of \$[-], for the purpose of paying all or a portion of the City's contractual obligations incurred in connection with the following public projects: (i) constructing and/or acquiring structured parking for public use and (ii) legal, fiscal and engineering fees in connection with such projects.

ON [FEBRUARY / AUGUST] 15, 203[], or on any date thereafter, the Certificates of this Series maturing on [February / August] 15, 203[4] and thereafter may be redeemed prior to their scheduled maturities, at the option of the City, in whole, or in part, at par and accrued interest to the date fixed for redemption. The years of maturity of the Certificates called for redemption at the option of the City prior to their stated maturity shall be selected by the City. The Certificates or portions thereof redeemed within a maturity shall be selected by lot or other method by the Paying Agent/Registrar; provided, that during any period in which ownership of the Certificates is determined only by a book entry at a securities depository for the Certificates, if fewer than all of the Certificates of the same maturity and bearing the same interest rate are to be redeemed, the particular Certificates of such maturity and bearing such interest rate shall be selected in accordance with the arrangements between the City and the securities depository.

THE CERTIFICATES SCHEDULED TO MATURE on [] 15, [-] (the "Term Certificates") are subject to scheduled mandatory redemption by the Paying Agent/Registrar by lot, or by any other customary method that results in a random selection, at a price equal to the principal amount thereof, plus accrued interest to the redemption date, out of moneys available for such purpose in the interest and sinking fund

for the Certificates, on each February 15 of the years and in the respective principal amounts, set forth in the following schedule:

Term Certificates due [February/August] 15, 20[-]

Mandatory Redemption Date: /15/20	Principal Amount: \$,000
Mandatory Redemption Date: /15/20*	Principal Amount: \$,000

\* Stated Maturity

[THE PRINCIPAL AMOUNT OF TERM CERTIFICATES of a stated maturity required to be redeemed on any mandatory redemption date pursuant to the operation of the mandatory sinking fund redemption provisions shall be reduced, at the option of the Issuer, by the principal amount of any Term Certificates of the same maturity which, at least 50 days prior to a mandatory redemption date (1) shall have been acquired by the Issuer at a price not exceeding the principal amount of such Term Certificates plus accrued interest to the date of purchase thereof, and delivered to the Paying Agent/Registrar for cancellation, (2) shall have been purchased and canceled by the Paying Agent/Registrar at the request of the Issuer at a price not exceeding the principal amount of such Term Certificates plus accrued interest to the date of purchase, or (3) shall have been redeemed pursuant to the optional redemption provisions and not theretofore credited against a mandatory redemption requirement.]

AT LEAST THIRTY days prior to the date fixed for any such redemption, a written notice of such redemption shall be given to the registered owner of each Certificate or a portion thereof being called for redemption by depositing such notice in the United States mail, first-class postage prepaid, addressed to each such registered owner at his address shown on the Registration Books of the Paying Agent/Registrar. By the date fixed for any such redemption due provision shall be made by the City with the Paying Agent/Registrar for the payment of the required redemption price for this Certificate or the portion hereof which is to be so redeemed, plus accrued interest thereon to the date fixed for redemption. If such notice of redemption is given, and if due provision for such payment is made, all as provided above, this Certificate, or the portion hereof which is to be so redeemed, thereby automatically shall be redeemed prior to its scheduled maturity, and shall not bear interest after the date fixed for its redemption, and shall not be regarded as being outstanding except for the right of the registered owner to receive the redemption price plus accrued interest to the date fixed for redemption from the Paying Agent/Registrar out of the funds provided for such payment. The Paying Agent/Registrar shall record in the Registration Books all such redemptions of principal of this Certificate or any portion hereof. If a portion of any Certificate shall be redeemed a substitute Certificate or Certificates having the same maturity date, bearing interest at the same rate, in Authorized Denominations, at the written request of the registered owner, and in aggregate principal amount equal to the unredeemed portion thereof, will be issued to the registered owner upon the surrender thereof for cancellation, at the expense of the City, all as provided in the Ordinance.

IF AT THE TIME OF MAILING of notice of optional redemption there shall not have either been deposited with the Paying Agent/Registrar or legally authorized escrow agent immediately available funds sufficient to redeem all the Certificates called for redemption, such notice must state that it is conditional, and is subject to the deposit of the redemption moneys with the Paying Agent/Registrar or legally authorized escrow agent at or prior to the redemption date, and such notice shall be of no effect unless such moneys are so deposited on or prior to the redemption date. If such redemption is not effectuated, the Paying Agent/Registrar shall, within five days thereafter, give notice in the manner in which the notice of redemption was given that such moneys were not so received and shall rescind the redemption.

ALL CERTIFICATES OF THIS SERIES are issuable solely as fully registered certificates, without interest coupons, in Authorized Denominations. As provided in the Certificate Ordinance, this Certificate may, at the request of the registered owner or the assignee or assignees hereof, be assigned, transferred, and exchanged for a like aggregate principal amount of fully registered certificates, without interest coupons, payable to the appropriate registered owner, assignee, or assignees, as the case may be, having the same maturity date, and bearing interest at the same rate, in Authorized Denominations as requested in writing by the appropriate registered owner, assignee, or assignees, as the case may be, upon surrender of this Certificate to the Paying Agent/Registrar at its Designated Trust Office for cancellation, all in accordance with the form and procedures set forth in the Certificate Ordinance. Among other requirements for such assignment and transfer, this Certificate must be presented and surrendered to the Paying Agent/Registrar at its Designated Trust Office, together with proper instruments of assignment, in form and with guarantee of signatures satisfactory to the Paying Agent/Registrar, evidencing assignment of this Certificate or any portion or portions hereof in an Authorized Denomination to the assignee or assignees in whose name or names this Certificate or any such portion or portions hereof is or are to be transferred and registered. The form of Assignment printed or endorsed on this Certificate may be executed by the registered owner to evidence the assignment hereof, but such method is not exclusive, and other instruments of assignment satisfactory to the Paying Agent/Registrar may be used to evidence the assignment of this Certificate or any portion or portions hereof from time to time by the registered owner. The foregoing notwithstanding, in the case of the exchange of an assigned and transferred Certificate or Certificates or any portion or portions thereof, such fees and charges of the Paying Agent/Registrar will be paid by the City. The one requesting such exchange shall pay the Paying Agent/Registrar's reasonable standard or customary fees and charges for exchanging any Certificate or portion thereof. In any circumstance, any taxes or governmental charges required to be paid with respect thereto shall be paid by the one requesting such assignment, transfer, or exchange as a condition precedent to the exercise of such privilege. In any circumstance, neither the City nor the Paying Agent/Registrar shall be required (1) to make any transfer or exchange during a period beginning at the opening of business 30 days before the day of the first mailing of a notice of redemption of Certificates and ending at the close of business on the day of such mailing, or (2) to transfer or exchange any Certificates so selected for redemption when such redemption is scheduled to occur within 45 calendar days.

WHENEVER the beneficial ownership of this Certificate is determined by a book entry at a securities depository for the Certificates, the foregoing requirements of holding, delivering or transferring this Certificate shall be modified to require the appropriate person or entity to meet the requirements of the securities depository as to registering or transferring the book entry to produce the same effect.

IN THE EVENT any Paying Agent/Registrar for the Certificates is changed by the City, resigns, or otherwise ceases to act as such, the City has covenanted in the Certificate Ordinance that it promptly will appoint a competent and legally qualified substitute therefor, and promptly will cause written notice thereof to be mailed to the registered owners of the Certificates.

IT IS HEREBY certified, recited and covenanted that this Certificate has been duly and validly authorized, issued, and delivered; that all acts, conditions, and things required or proper to be performed, exist, and be done precedent to or in the authorization, issuance, and delivery of this Certificate have been performed, existed, and been done in accordance with law; that this Certificate is a direct obligation of said City, issued on the full faith and credit thereof; and that in accordance with the terms of the Certificate Ordinance, annual ad valorem taxes sufficient to provide for the payment of the interest on and principal of this Certificate, as such interest comes due and such principal matures, have been levied and ordered to be levied against all taxable property in said City, and have been pledged for such payment, within the limit prescribed by law; and that a pledge of the Surplus Revenues from the operation of the City's waterworks and sewer system remaining after payment of all operation and maintenance expenses thereof, and all debt service, reserve, and other requirements in connection with all of the City's revenue bonds or other

obligations (now or hereafter outstanding), which are payable from all or any part of the net revenues of the City's waterworks and sewer system remaining after payment of all operation and maintenance expenses thereof and any other obligations heretofore or hereafter incurred to which such revenues have been or shall be encumbered by a lien on and pledge of such revenues superior to the lien on and pledge of such revenues to the Certificates, have been pledged as additional security for the Certificates.

BY BECOMING the registered owner of this Certificate, the registered owner thereby acknowledges all of the terms and provisions of the Certificate Ordinance, agrees to be bound by such terms and provisions, acknowledges that the Certificate Ordinance is duly recorded and available for inspection in the official minutes and records of the City, and agrees that the terms and provisions of this Certificate and the Certificate Ordinance constitute a contract between each registered owner hereof and the City.

IN WITNESS WHEREOF, this Certificate has been signed with the manual or facsimile signature of the Mayor of the City, attested by the manual or facsimile signature of the City Secretary, and the official seal of the City has been duly affixed to, or impressed, or placed in facsimile, on this Certificate.

\_\_\_\_\_  
City Secretary

\_\_\_\_\_  
Mayor

(CITY SEAL)

FORM OF PAYING AGENT/REGISTRAR'S AUTHENTICATION CERTIFICATE

PAYING AGENT/REGISTRAR'S AUTHENTICATION CERTIFICATE

It is hereby certified that this Certificate of Obligation has been issued under the provisions of the proceedings adopted by the City as described in the text of this Certificate of Obligation; and that this Certificate of Obligation has been issued in exchange for or replacement of a Certificate of Obligation of an issue which originally was approved by the Attorney General of the State of Texas and registered by the Comptroller of Public Accounts of the State of Texas.

Dated: \_\_\_\_\_  
ASSOCIATION

U.S. BANK TRUST COMPANY, NATIONAL  
Dallas, Texas  
Paying Agent/Registrar

By: \_\_\_\_\_  
Authorized Representative

FORM OF COMPTROLLER'S CERTIFICATE

[ATTACHED TO CERTIFICATES NO. T-1 AND TR-1 UPON INITIAL DELIVERY THEREOF]

COMPTROLLER'S CERTIFICATE

OFFICE OF COMPTROLLER

§

REGISTER NO. \_\_\_\_\_

STATE OF TEXAS

§

I hereby certify that there is on file and of record in my office a true and correct copy of the opinion of the Attorney General of the State of Texas approving this Certificate and that this Certificate has been registered this day by me.

WITNESS MY HAND and seal of office at Austin, Texas this \_\_\_\_\_.

\_\_\_\_\_  
Comptroller of Public Accounts of the State of  
Texas

(SEAL)

FORM OF ASSIGNMENT

ASSIGNMENT

For value received, the undersigned hereby sells, assigns and transfers unto:

\_\_\_\_\_  
*Please insert Social Security or Taxpayer Identification Number of Transferee*

\_\_\_\_\_  
*Please print or type name and address, including zip code of Transferee*

the within Certificate and all rights thereunder, and hereby irrevocably constitutes and appoints: \_\_\_\_\_, attorney, to register the transfer of the within Certificate on the books kept for registration thereof, with full power of substitution in the premises.

Dated: \_\_\_\_\_.

Signature Guaranteed:

\_\_\_\_\_  
NOTICE: Signature(s) must be guaranteed by an eligible guarantor institution participating in a securities transfer association recognized signature guarantee program.

\_\_\_\_\_  
NOTICE: The signature above must correspond with the name of the registered owner as it appears upon the front of this Certificate in every particular, without alteration or enlargement or any change whatsoever.

INSERTIONS FOR THE INITIAL CERTIFICATE. The initial Certificate shall be in the form set forth in paragraph (a) of this Form of Certificate, except that:

- i. immediately under the name of the Certificate, the headings "INTEREST RATE" and "MATURITY DATE" shall both be completed with the words "As shown below" and "CUSIP NO. \_\_\_\_\_" shall be deleted.
- ii the first paragraph shall be deleted and the following will be inserted:

"THE CITY OF ROANOKE, TEXAS, in Tarrant and Denton Counties, Texas (the "City"), being a political subdivision of the State of Texas, hereby promises to pay to the Registered Owner specified above or to the registered assignee hereof (either being hereinafter called the "registered owner") on the Maturity Dates, in the Principal Amounts and bearing interest at the per annum Interest Rates set forth in the following schedule:

Maturity Date	Principal Amount	Interest Rate
[-]	[-]	[-]

The City promises to pay interest on the unpaid principal amount hereof (calculated on the basis of a 360-day year of twelve 30-day months) from the Delivery Date above at the respective Interest Rate per annum specified above. Interest is payable on [February/August] 15, 202[] and on each August 15 and February 15 thereafter to the date of payment of the Principal Amounts specified above, or the date of redemption prior to maturity; except, that if this Certificate is required to be authenticated and the date of its authentication is later than the first Record Date (hereinafter defined), such principal amount shall bear interest from the interest payment date next preceding the date of authentication, unless such date of authentication is after any Record Date but on or before the next following interest payment date, in which case such principal amount shall bear interest from such next following interest payment date; provided, however, that if on the date of authentication hereof the interest on the Certificate or Certificates, if any, for which this Certificate is being exchanged is due but has not been paid, then this Certificate shall bear interest from the date to which such interest has been paid in full."

iii. The initial Certificate shall be numbered "T-1."



## AGENDA ITEM

TO: Mayor and City Council

SUBJECT: General Obligation Bonds-Convention Center

MEETING DATE: June 23, 2026

DEPARTMENT: Administration

---

### ITEM SUMMARY:

Consider and act on Ordinance No. 2026-138 authorizing the issuance of general obligation bonds; delegating the authority to certain city officials to execute certain documents relating to the sale of the bonds; approving and authorizing an official statement and instruments and procedures relating to the bonds; and enacting other provisions relating to the subject.

### INFORMATION:

### STAFF RECOMMENDATION:

### SPECIAL CONSIDERATION:

### FINANCIAL CONSIDERATION:

### ATTACHMENTS:

1. Ordinance No. 2026-138 - GO Bonds 2026 - Conv Center

CERTIFICATE FOR ORDINANCE

THE STATE OF TEXAS  
TARRANT AND DENTON COUNTIES  
CITY OF ROANOKE, TEXAS

We, the undersigned officers of the City Council of the City of Roanoke, Texas hereby certify as follows:

1. The City Council convened in a regular meeting on June 23, 2026, at the regular designated meeting place, and the roll was called of the duly constituted officers and members of the City Council, to wit:

Scooter Gierisch, Mayor  
 Brian Darby  
 David Thompson  
 John Pullen

Holly Gray, Mayor Pro Tem  
 David Brundage  
 Ernie Adams

and all of the above persons were present except \_\_\_\_\_, thus constituting a quorum. Whereupon, among other business the following was transacted at the Meeting: a written Ordinance entitled

ORDINANCE AUTHORIZING THE ISSUANCE OF GENERAL OBLIGATION BONDS; DELEGATING THE AUTHORITY TO CERTAIN CITY OFFICIALS TO EXECUTE CERTAIN DOCUMENTS RELATING TO THE SALE OF THE BONDS; APPROVING AND AUTHORIZING AN OFFICIAL STATEMENT AND INSTRUMENTS AND PROCEDURES RELATING TO THE BONDS; AND ENACTING OTHER PROVISIONS RELATING TO THE SUBJECT

was duly introduced for the consideration of the City Council. It was then duly moved and seconded that the Order be passed; and, after due discussion, the motion, carrying with it the passage of the Order, prevailed and carried, with all members of the City Council shown present above voting "Aye," except as noted below:

NAYS: \_\_\_\_\_ ABSTENTIONS: \_\_\_\_\_

2. A true, full, and correct copy of the Ordinance passed at the Meeting described in the above and foregoing paragraph is attached to and follows this Certificate; the Ordinance has been duly recorded in the Council's minutes of the Meeting; the above and foregoing paragraph is a true, full, and correct excerpt from the City Council's minutes of the Meeting pertaining to the passage of the Ordinance; the persons named in the above and foregoing paragraph are the duly chosen, qualified, and acting officers and members of the City Council as indicated therein; that each of the officers and members of the City Council was duly and sufficiently notified officially and personally, in advance, of the time, place, and purpose of the Meeting, and that the Ordinance would be introduced and considered for passage at the Meeting, and each of the officers and members consented, in advance, to the holding of the Meeting for such purpose; and that the Meeting was open to the public, and public notice of the time, place, and purpose of the Meeting was given all as required by the Texas Government Code, Chapter 551.

3. The Mayor of the City Council has approved and hereby approves the Ordinance; and the Mayor and the City Secretary of the City hereby declare that their signing of this certificate shall constitute the signing of the attached and following copy of the Ordinance for all purposes.

SIGNED AND SEALED ON JUNE 23, 2026

---

Lindsay Rawlinson  
City Secretary

---

Carl E. Gierisch, Jr. Mayor

(CITY SEAL)

ORDINANCE NO. 2026-138

ORDINANCE AUTHORIZING THE ISSUANCE OF GENERAL OBLIGATION BONDS; DELEGATING THE AUTHORITY TO CERTAIN CITY OFFICIALS TO EXECUTE CERTAIN DOCUMENTS RELATING TO THE SALE OF THE BONDS; APPROVING AND AUTHORIZING AN OFFICIAL STATEMENT AND INSTRUMENTS AND PROCEDURES RELATING TO THE BONDS; AND ENACTING OTHER PROVISIONS RELATING TO THE SUBJECT

WHEREAS, by virtue of an election held within the City of Roanoke, Texas ("the Issuer"), this City Council became authorized to issue, sell and deliver the general obligation bonds of the Issuer, of which there has been previously issued and are authorized to be issued by this Ordinance, as described in the following proposition submitted to and approved by the voters of the Issuer:

CITY OF ROANOKE PROPOSITION A

Shall the City Council of the City of Roanoke be authorized to issue the bonds of said, in one or more series or issues, in the aggregate principal amount of \$62,000,000, with the bonds of each such series or issue, respectively, to mature serially within not to exceed forty years from their date, and to be sold at such prices and bear interest at such rates as shall be determined within the discretion of the City Council, for the purpose of designing, constructing and equipping a convention center facility consisting of conference and meeting rooms, ballrooms, and gathering space that is to be in proximity to and integrated with a full-service convention center hotel and to be leased to a private operator for such purposes, and shall said City Council be authorized to levy and cause to be assessed and collected annual ad valorem taxes in an amount sufficient to pay the annual interest on said bonds and provide a sinking fund to pay said bonds at maturity?;

WHEREAS, this City Council finds and determines that it is necessary and proper to authorize the issuance, sale and delivery of a portion of such voted bonds;

WHEREAS, the Issuer is an "Issuer" under Section 1371.001(4)(P), Texas Government Code, having (i) a principal amount of at least \$100 million in outstanding long-term indebtedness, in long-term indebtedness proposed to be issued, or a combination of outstanding or proposed long-term indebtedness and (ii) some amount of long-term indebtedness outstanding or proposed to be issued that is rated in one of the four highest rating categories for long-term debt instruments by a nationally recognized rating agency for municipal securities, without regard to the effect of any credit agreement or other form of credit enhancement entered into in connection with the obligation;

WHEREAS, the Bonds hereinafter authorized to be issued are to be issued, sold and delivered pursuant to the general laws of the State of Texas, including Texas Government Code, Chapters 1251, 1331 and 1371, as amended and the City's Home Rule Charter; and

WHEREAS, it is officially found, determined, and declared that the meeting at which this Ordinance has been adopted was open to the public and public notice of the time, place and subject matter of the public business to be considered and acted upon at the meeting, including this Ordinance, was given, all as required by the applicable provisions of Texas Government Code, Chapter 551;

THEREFORE, BE IT ORDAINED BY THE CITY COUNCIL OF THE CITY OF ROANOKE, TEXAS:

Section 1. DEFINITIONS; AUTHORIZATION OF BONDS.

(a) Definitions. Terms not otherwise defined herein shall have the following meanings.

(i) The term "Authorized Denomination" shall mean a denomination of \$5,000 of principal amount of a Bond or any integral multiple thereof.

(ii) The term "Business Day" means any day other than a Saturday, Sunday, a legal holiday, or a day on which banking institutions in the City are, authorized by law or executive order to close.

(iii) The term "Bonds" shall mean the Bonds authorized to be issued and delivered by this Ordinance, unless such series designation is changed in the Pricing Certificate to reflect the actual sale of the Bonds.

(iv) The term "Financial Obligation" means a: (a) debt obligation; (b) derivative instrument entered into in connection with, or pledged as security or a source of payment for, an existing or planned debt obligation; or (c) a guarantee of the foregoing (a) and (b). The term Financial Obligation does not include any municipal securities as to which a final official statement has been provided to the MSRB consistent with the Rule.

(v) The term "MSRB" means the Municipal Securities Rulemaking Board.

(vi) The term "Pricing Certificate" means a certificate of the Pricing Officer setting forth the terms of sale of the Bonds including the method of sale, principal amount, maturity dates, interest payment dates, dated date, interest rates, yields, redemption provisions, and other matters related to the sale of the Bonds.

(vii) The term "Pricing Officer" means the Mayor, the City Manager and the Chief Financial Officer (each the "Pricing Officer") each of whom is independently authorized to finalize the terms of sale of the Bonds by execution of the Pricing Certificate.

(viii) The term "Purchaser" means (i) if the Bonds are sold by negotiated sale, the underwriter or underwriting syndicate selected by the Pricing Officer, or (ii) if the Bonds are sold by competitive sale by soliciting public bids, the underwriter or underwriting syndicate awarded the Bonds by the Pricing Officer.

(ix) The term "Rule" means SEC Rule 15c2-12 (17 C.F.R. § 240.15C2-12), as amended from time to time.

(x) The term "SEC" means the United States Securities and Exchange Commission.

(b) The City of Roanoke, Texas (the "Issuer") hereby authorizes to be issued and delivered the Bonds, in one or more series, for the following public purposes: (i) designing, constructing and equipping a convention center facility consisting of conference and meeting rooms, ballrooms, and gathering space that is to be in proximity to and integrated with a full-service convention center hotel and to be leased to a private operator for such purposes and (ii) paying costs of issuance of the Bonds (collectively, the "Projects"). The maximum par amount of the Bonds may not exceed \$62,000,000.

(c) Each Bond issued pursuant to this Ordinance shall be designated: "CITY OF ROANOKE, TEXAS, GENERAL OBLIGATION BOND, SERIES 2026", and initially there shall be issued, sold, and

delivered hereunder fully registered Bonds, without interest coupons, payable to the respective registered owners thereof (with the initial bonds being made payable to the initial purchaser as described in Section 10 hereof), or to the registered assignee or assignees of the bonds or any portion or portions thereof (in each case, the "Registered Owner"). The Bonds shall be in the respective denominations and principal amounts, shall be numbered, shall mature and be payable on the date or dates in each of the years and in the principal amounts, and shall bear interest to their respective dates of maturity or redemption prior to maturity at the rates per annum, as set forth in the Pricing Certificate for such series of Bonds.

(d) As authorized by Sections 1371.053 and 1207.007, Texas Government Code, each Pricing Officer is hereby authorized to act individually and severally on behalf of the City in selling and delivering the Bonds, carrying out the other procedures specified in this Ordinance, including, determining the date of the Bonds, any additional or different designation or title by which the Bonds shall be known, whether the Bonds shall be sold and delivered in one or more series and the date and sale and delivery of each such series, the price at which the Bonds will be sold, the years in which the Bonds will mature, the principal amount to mature in each of such years, the rate of interest to be borne by each such maturity, the interest payment and record dates, the price and terms upon and at which the Bonds shall be subject to redemption prior to maturity at the option of the City, as well as any mandatory sinking fund redemption provisions, and all other matters relating to the issuance, sale, and delivery of the Bonds and obtaining municipal insurance for all or any portion of the Bonds and providing for the terms and provisions thereof applicable to the Bonds, all of which shall be specified in the Pricing Certificate.

(e) No series of Bonds shall be issued pursuant to this Ordinance unless each of the following parameters are satisfied as specified in the Pricing Certificate:

(i) the principal amount of the Bonds shall not exceed \$62,000,000;

(ii) the true interest cost of the Bonds shall not exceed 6.00% per annum;

(iii) the final maturity of the Bonds shall not exceed August 15, 2056;

(iv) the delegation made hereby shall expire if not exercised by the Pricing Officer on or prior one year from the date of adoption of this Ordinance; and

(v) on or prior to delivery, the Bonds shall be rated by a nationally recognized rating agency for municipal securities in one of the four highest categories for long-term obligations.

(f) In establishing the aggregate principal amount of the Bonds, the Pricing Officer shall establish an amount that, when combined with premium used for purposes other than the payment of costs of issuance, does not exceed the amount authorized in Subsection (b) hereof, which shall be sufficient in amount to provide for the purposes for which the Bonds are authorized and to pay costs of issuing the Bonds. The Bonds shall be sold with and subject to such terms as set forth in the Pricing Certificate.

(g) The Bonds may be sold by public offering (either through a negotiated or competitive offering) and the Pricing Certificate shall so state, and the Pricing Certificate may conform this Ordinance to such method of sale, including the provisions hereof that pertain to the undertaking of the Issuer in accordance with the Rule.

(h) The City Council hereby determines that the delegation of the authority to the Pricing Officer to approve the final terms of the Bonds as set forth in this Ordinance is, and the decisions made by the Pricing Officer pursuant to such delegated authority and incorporated into the Pricing Certificate are required to be, in the Issuer's best interests, and the Pricing Officer is hereby authorized to make and include in the Pricing Certificate a finding to that effect.

### **Section 3. CHARACTERISTICS OF THE BONDS.**

(a) The City shall keep or cause to be kept at the corporate trust office in Dallas, Texas (the "Designated Trust Office") of U.S. BANK TRUST COMPANY, NATIONAL ASSOCIATION (the "Paying Agent/Registrar"), books or records for the registration and transfer of the Bonds (the "Registration Books"), and the City hereby appoints the Paying Agent/Registrar as its registrar and transfer agent to keep such books or records and make such transfers and registrations under such reasonable regulations as the City and the Paying Agent/Registrar may prescribe; and the Paying Agent/Registrar shall make such transfers and registrations as herein provided. It shall be the duty of the Paying Agent/Registrar to obtain from the registered owner and record in the Registration Books the address of the registered owner of each Bond to which payments with respect to the Bonds shall be mailed, as herein provided. The City or its designee shall have the right to inspect the Registration Books during regular business hours of the Paying Agent/Registrar at its Designated Trust Office, but otherwise the Paying Agent/Registrar shall keep the Registration Books confidential and, unless otherwise required by law, shall not permit their inspection by any other entity. Registration of each Bond may be transferred in the Registration Books only upon presentation and surrender thereof to the Paying Agent/Registrar at its Designated Trust Office for transfer of registration and cancellation, together with proper written instruments of assignment, in form and with guarantee of signatures satisfactory to the Paying Agent/Registrar, evidencing the assignment of such Bond, or any portion thereof in any Authorized Denomination, to the assignee or assignees thereof, and the right of such assignee or assignees to have such Bond or any such portion thereof registered in the name of such assignee or assignees. Upon the assignment and transfer of any Bond or any portion thereof, a new substitute Bond or Bonds shall be issued in exchange therefor in the manner herein provided.

(b) The entity in whose name any Bond shall be registered in the Registration Books at any time shall be treated as the absolute owner thereof for all purposes of this Ordinance, whether or not such Bond shall be overdue, and the City and the Paying Agent/Registrar shall not be affected by any notice to the contrary; and payment of, or on account of, the principal of, premium, if any, and interest on any such Bond shall be made only to such registered owner. All such payments shall be valid and effectual to satisfy and discharge the liability upon such Bond to the extent of the sum or sums so paid.

(c) The City hereby further appoints the Paying Agent/Registrar to act as the paying agent for paying the principal of and interest on the Bonds, and to act as its agent to exchange or replace Bonds, all as provided in this Ordinance. The Paying Agent/Registrar shall keep proper records of all payments made by the City and the Paying Agent/Registrar with respect to the Bonds, and of all exchanges thereof, and all replacements thereof, as provided in this Ordinance.

(d) Each Bond may be exchanged for fully registered Bonds in the manner set forth herein. Each Bond issued and delivered pursuant to this Ordinance may, upon surrender thereof at the Designated Trust Office of the Paying Agent/Registrar, together with a written request therefor duly executed by the registered owner or the assignee or assignees thereof, or its or their duly authorized attorneys or representatives, with guarantee of signatures satisfactory to the Paying Agent/Registrar, at the option of the registered owner or such assignee or assignees, as appropriate, be exchanged for fully registered Bonds, without interest coupons, in the form prescribed in the FORM OF BOND, in an Authorized Denomination (subject to the requirement hereinafter stated that each substitute Bond shall have a single stated maturity date), as requested in writing by such registered owner or such assignee or assignees, in an aggregate principal amount equal to the principal amount of any Bond or Bonds so surrendered, and payable to the appropriate registered owner, assignee, or assignees, as the case may be. If any Bond or portion thereof is assigned and transferred, each Bond issued in exchange therefor shall have the same principal maturity date and bear interest at the same rate as the Bond for which it is being exchanged. Each substitute Bond shall bear a letter and/or number to distinguish it from each other Bond. The Paying Agent/Registrar shall exchange or replace Bonds as provided herein, and each fully registered Bond or Bonds delivered in

exchange for or replacement of any Bond or portion thereof as permitted or required by any provision of this Ordinance shall constitute one of the Bonds for all purposes of this Ordinance, and may again be exchanged or replaced. It is specifically provided, however, that any Bond delivered in exchange for or replacement of another Bond prior to the first scheduled interest payment date on the Bonds (as stated on the face thereof) shall be dated the same date as such Bond, but each substitute Bond so delivered on or after such first scheduled interest payment date shall be dated as of the interest payment date preceding the date on which such substitute Bond is delivered, unless such substitute Bond is delivered on an interest payment date, in which case it shall be dated as of such date of delivery; provided, however, that if at the time of delivery of any substitute Bond the interest on the Bond for which it is being exchanged has not been paid, then such substitute Bond shall be dated as of the date to which such interest has been paid in full. On each substitute Bond issued in exchange for or replacement of any Bond or Bonds issued under this Ordinance there shall be printed thereon a Paying Agent/Registrar's Authentication Certificate, in the form hereinafter set forth in the FORM OF BOND (the "Authentication Certificate"). An authorized representative of the Paying Agent/Registrar shall, before the delivery of any such substitute Bond, date such substitute Bond in the manner set forth above, and manually sign and date the Authentication Certificate, and no such substitute Bond shall be deemed to be issued or outstanding unless the Authentication Certificate is so executed. The Paying Agent/Registrar promptly shall cancel all Bonds surrendered for exchange or replacement. No additional ordinances, orders, or resolutions need be passed or adopted by the City Council or any other body or person so as to accomplish the foregoing exchange or replacement of any Bonds or portion thereof, and the Paying Agent/Registrar shall provide for the printing, execution, and delivery of the substitute Bond in the manner prescribed herein. Pursuant to Chapter 1206, Texas Government Code, the duty of exchange or replacement of any Bonds as aforesaid is hereby imposed upon the Paying Agent/Registrar, and, upon the execution of Authentication Certificate, the exchanged or replaced Bond shall be valid, incontestable, and enforceable in the same manner and with the same effect as the Bonds which originally were delivered pursuant to this Ordinance, approved by the Attorney General, and registered by the Comptroller of Public Accounts. Neither the City nor the Paying Agent/Registrar shall be required to transfer or exchange any Bond so selected for redemption, in whole or in part, within 45 calendar days of the date fixed for redemption; provided, however, such limitation of transfer shall not be applicable to an exchange by the registered owner of the uncalled principal of a Bond.

(e) All Bonds issued in exchange or replacement of any other Bond or portion thereof, (i) shall be issued in fully registered form, without interest coupons, with the principal of and interest on such Bonds to be payable only to the registered owners thereof, (ii) may be transferred and assigned, (iii) may be exchanged for other Bonds, (iv) shall have the characteristics, (v) shall be signed and sealed, and (vi) the principal of and interest on the Bonds shall be payable, all as provided, and in the manner required or indicated, in the FORM OF BOND.

(f) The City shall pay the Paying Agent/Registrar's reasonable and customary fees and charges for making transfers of Bonds, but the registered owner of any Bond requesting such transfer shall pay any taxes or other governmental charges required to be paid with respect thereto. The registered owner of any Bonds requesting any exchange shall pay the Paying Agent/Registrar's reasonable and standard or customary fees and charges for exchanging any such Bond or portion thereof, together with any taxes or governmental charges required to be paid with respect thereto, all as a condition precedent to the exercise of such privilege of exchange, except, however, that in the case of the exchange of an assigned and transferred Bond or Bonds or any portion or portions thereof in an Authorized Denomination, as provided in this Ordinance, such fees and charges will be paid by the City. In addition, the City hereby covenants with the registered owners of the Bonds that it will (i) pay the reasonable and standard or customary fees and charges of the Paying Agent/Registrar for its services with respect to the payment of the principal of and interest on Bonds, when due, and (ii) pay the fees and charges of the Paying Agent/Registrar for services with respect to the transfer or registration of Bonds solely to the extent above provided, and with respect to the exchange of Bonds solely to the extent above provided.

(g) The City covenants with the registered owners of the Bonds that at all times while the Bonds are outstanding the City will provide a competent and legally qualified bank, trust company, financial institution, or other agency to act as and perform the services of Paying Agent/Registrar for the Bonds under this Ordinance, and that the Paying Agent/Registrar will be one entity. The City reserves the right to, and may, at its option, change the Paying Agent/Registrar upon not less than sixty days written notice to the Paying Agent/Registrar. In the event that the entity at any time acting as Paying Agent/Registrar (or its successor by merger, acquisition, or other method) should resign or otherwise cease to act as such, the City covenants that it will promptly appoint a competent and legally qualified national or state banking institution which shall be a corporation organized and doing business under the laws of the United States of America or of any state, authorized under such laws to exercise trust powers, subject to supervision or examination by federal or state authority, and whose qualifications substantially are similar to the previous Paying Agent/Registrar to act as Paying Agent/Registrar under this Ordinance. Upon any change in the Paying Agent/Registrar, the previous Paying Agent/Registrar promptly shall transfer and deliver the Registration Books (or a copy thereof), along with all other pertinent books and records relating to the Bonds, to the new Paying Agent/Registrar designated and appointed by the City. Upon any change in the Paying Agent/Registrar, the City promptly will cause a written notice thereof to be sent by the new Paying Agent/Registrar to each registered owner of the Bonds, by United States mail, first-class postage prepaid, which notice also shall give the address of the new Paying Agent/Registrar. By accepting the position and performing as such, each Paying Agent/Registrar shall be deemed to have agreed to the provisions of this Ordinance, and a certified copy of this Ordinance shall be delivered to each Paying Agent/Registrar.

**Section 4. FORM OF BONDS.** The form of the Bonds, including the form of the Authentication Certificate, the form of Assignment and the form of Registration Certificate of the Comptroller of Public Accounts of the State of Texas to be attached to the Bonds initially issued and delivered pursuant to this Ordinance, shall be in substantially the form as set forth in **Exhibit A** to this Ordinance. The Bonds shall be numbered consecutively from R-1 upward, with the Initial Bond being numbered T-1, with such appropriate variations, omissions, or insertions as are permitted or required by this Ordinance and with the FORM OF BOND to be modified pursuant to, and completed with information set forth in the Pricing Certificate. The FORM OF BOND as it appears in **Exhibit A** shall be completed, amended and modified by Bond Counsel to incorporate the information set forth in the Pricing Certificate but it is not required for the FORM OF BOND to reproduced as an exhibit to the Pricing Certificate. The printer of the Bonds is hereby authorized to print on the Bonds (i) the form of bond counsel's opinion relating to the Bonds, and (ii) an appropriate statement of insurance furnished by a municipal bond insurance company providing municipal bond insurance, if any, covering all or any part of the Bonds.

#### **Section 5. REDEMPTION PROVISIONS.**

(a) *Optional Redemption.* The Bonds may be subject to optional redemption prior to maturity on the dates and at the redemption prices as set forth in the Pricing Certificate. The Pricing Officer is hereby delegated to make such modifications to the provisions of this section in the Pricing Certificate as are necessary to complete the sale and delivery of the Bonds.

(b) *Notice of Redemption.* At least thirty days prior to the date fixed for any redemption of Bonds, or portions thereof, prior to maturity, the Issuer shall cause written notice of such redemption to be sent by United States mail, first class, postage prepaid, to each Registered Owner of a Bond to be redeemed, in whole or in part, at the address of the Registered Owner appearing on the registration books of the Paying Agent/Registrar at the close of business on the business day next preceding the date of mailing of such notice. All notices of redemption so mailed shall be conclusively presumed to have been duly given irrespective of whether received by the Registered Owner.

(c) *Firm Banking and Financial Arrangements.* By the date fixed for any prior redemption, due provision shall be made with the Paying Agent/Registrar for the payment of the required redemption price for the Bonds or portions thereof that are to be redeemed. If written notice of redemption is mailed and if due provision for such payment is made, all as provided above, the Bonds or portions thereof that are to be redeemed shall automatically be treated as redeemed prior to their scheduled maturities, and they shall not bear interest after the date fixed for redemption, and they shall not be regarded as being outstanding except for the right of the Registered Owner to receive the redemption price from the Paying Agent/Registrar out of the funds provided for such payment. If a portion of any Bond shall be redeemed, a substitute Bond having the same maturity date, bearing interest at the same rate, in an Authorized Denomination, at the written request of the Registered Owner, and in an aggregate principal amount equal to the unredeemed portion thereof, will be issued to the Registered Owner upon the surrender thereof for cancellation, at the expense of the Issuer.

(d) *Selection of Bonds for Redemption.* If less than all Bonds of the same maturity are to be redeemed on a redemption date, the Paying Agent/Registrar shall randomly select by lot the Bonds within such maturity to be redeemed.

(e) *Conditional Notice of Redemption.* With respect to any optional redemption of the Bonds, unless certain prerequisites to such redemption required by this Order have been met and moneys sufficient to pay the principal of and premium, if any, and interest on the Bonds to be redeemed shall have been received by the Paying Agent/Registrar prior to the giving of such notice of redemption, such notice shall state that said redemption may, at the option of the Issuer, be conditional upon the satisfaction of such prerequisites and receipt of such moneys by the Paying Agent/Registrar on or prior to the date fixed for such redemption, or upon any prerequisite set forth in such notice of redemption. If a conditional notice of redemption is given and such prerequisites to the redemption and sufficient moneys are not received, such notice shall be of no force and effect, the Issuer shall not redeem such Bonds and the Paying Agent/Registrar shall give notice, in the manner in which the notice of redemption was given, to the effect that the Bonds have not been redeemed.

## **Section 6. LEVY OF TAX; INTEREST AND SINKING FUND.**

(a) A special fund or account, to be designated the "City of Roanoke GO Series 2026 Interest and Sinking Fund" (the "Interest and Sinking Fund") is hereby created and shall be established and maintained by the City. The Interest and Sinking Fund shall be kept separate and apart from all other funds and accounts of the City, and shall be used only for paying the interest on and principal of the Bonds. All ad valorem taxes levied and collected for and on account of the Bonds shall be deposited, as collected, to the credit of the respective Interest and Sinking Fund. During each year while any of the Bonds are outstanding and unpaid, the governing body of the City shall compute and ascertain the rate and amount of ad valorem tax, based on the latest approved tax rolls of the City, with full allowances being made for tax delinquencies and the cost of tax collections, which will be sufficient to raise and produce the money required to pay the interest on the Bonds as such interest comes due, and to provide a sinking fund to pay the principal (including mandatory sinking fund redemption payments, if any) of the Bonds as such principal matures or comes due through operation of the mandatory sinking fund redemption, if any, but never less than 2% of the original amount of the Bonds as a sinking fund each year. The rate and amount of ad valorem tax is hereby ordered to be levied against all taxable property in the City for each year while any of the Bonds is outstanding and unpaid, and the ad valorem tax shall be assessed and collected each such year and deposited to the credit of the Interest and Sinking Fund. Ad valorem taxes necessary to pay the interest on and principal of the Bonds, as such interest comes due and such principal matures, are hereby pledged for such payment, within the limit prescribed by law.

(b) Application of Chapter 1208, Government Code. Chapter 1208, Texas Government Code, applies to the issuance of the Bonds and the pledge of ad valorem taxes granted by the City under this section, and such pledge is therefore valid, effective, and perfected. If Texas law is amended at any time while the Bonds are outstanding and unpaid such that the pledge of the ad valorem taxes granted by the City is to be subject to the filing requirements of Chapter 9, Texas Business & Commerce Code, then in order to preserve to the Registered Owners of the Bonds the perfection of the security interest in said pledge, the City agrees to take such measures as it determines are reasonable and necessary under Texas law to comply with the applicable provisions of Chapter 9, Texas Business & Commerce Code and enable a filing to perfect the security interest in said pledge to occur.

(c) In order to pay any debt service coming due on the Bonds prior to receipt of the taxes levied to pay such debt service, there is hereby appropriated from current funds on hand, which are hereby certified to be on hand and available for such purpose, an amount sufficient to pay such debt service, and such amount shall be used for no other purpose.

(d) The City shall do any and all things necessary to accomplish the transfer of monies to the Interest and Sinking Fund of this issue in ample time to pay such items of principal and interest due on the Bonds.

(e) The Interest and Sinking Fund created by this Ordinance shall be secured in the manner and to the fullest extent permitted or required by law for the security of public funds, and such Interest and Sinking Fund shall be used only for the purposes and in the manner permitted or required by this Ordinance.

#### **Section 7. DAMAGED, MUTILATED, LOST, STOLEN, OR DESTROYED BONDS.**

(a) *Replacement Bonds.* In the event any outstanding Bond is damaged, mutilated, lost, stolen, or destroyed, the Paying Agent/Registrar shall cause to be printed, executed, and delivered, a new Bond of the same principal amount, maturity, and interest rate, as the damaged, mutilated, lost, stolen, or destroyed Bond, in replacement for such Bond in the manner hereinafter provided.

(b) *Application for Replacement Bonds.* Application for replacement of damaged, mutilated, lost, stolen, or destroyed Bonds shall be made by the registered owner thereof to the Paying Agent/Registrar. In every case of loss, theft, or destruction of a Bond, the registered owner applying for a replacement Bond shall furnish to the City and to the Paying Agent/Registrar such security or indemnity as may be required by them to save each of them harmless from any loss or damage with respect thereto. Also, in every case of loss, theft, or destruction of a Bond, the registered owner shall furnish to the City and to the Paying Agent/Registrar evidence to their satisfaction of the loss, theft, or destruction of such Bond, as the case may be. In every case of damage or mutilation of a Bond, the registered owner shall surrender to the Paying Agent/Registrar for cancellation the Bond so damaged or mutilated.

(c) *No Default Occurred.* Notwithstanding the foregoing provisions of this Section, in the event any such Bond shall have matured, and no default has occurred which is then continuing in the payment of the principal of, redemption premium, if any, or interest on the Bond, the City may authorize the payment of the same (without surrender thereof except in the case of a damaged or mutilated Bond) instead of issuing a replacement Bond, provided security or indemnity is furnished as above provided in this Section.

(d) *Charge for Issuing Replacement Bonds.* Prior to the issuance of any replacement Bond, the Paying Agent/Registrar shall charge the registered owner of such Bond with all legal, printing, and other expenses in connection therewith. Every replacement Bond issued pursuant to the provisions of this Section by virtue of the fact that any Bond is lost, stolen, or destroyed shall constitute a contractual obligation of the City whether or not the lost, stolen, or destroyed Bond shall be found at any time, or be enforceable by

anyone, and shall be entitled to all the benefits of this Ordinance equally and proportionately with any and all other Bonds duly issued under this Ordinance.

(e) *Authority for Issuing Replacement Bonds.* In accordance with Section 1201.067, Texas Government Code, this Section of this Ordinance shall constitute authority for the issuance of any such replacement Bond without necessity of further action by the City or any other body or person, and the duty of the replacement of such Bonds is hereby authorized and imposed upon the Paying Agent/Registrar, and the Paying Agent/Registrar shall authenticate and deliver such Bonds in the form and manner and with the effect, as provided in Section 4(d) of this Ordinance for Bonds issued in conversion and exchange of other Bonds.

## **Section 8. FEDERAL INCOME TAX MATTERS.**

(a) *Covenants.* The Issuer covenants to take any action necessary to assure, or refrain from any action which would adversely affect, the treatment of the Bonds as obligations described in section 103 of the Code, the interest on which is not includable in the "gross income" of the Registered Owner for purposes of federal income taxation. In furtherance thereof, the Issuer covenants as follows:

(i) to take any action to assure that no more than 10 percent of the proceeds of the Bonds or the projects financed therewith (less amounts deposited to a reserve fund, if any) are used for any "private business use," as defined in section 141(b)(6) of the Code or, if more than 10 percent of the proceeds or the projects financed therewith are so used, such amounts, whether or not received by the Issuer, with respect to such private business use, do not, under the terms of this Resolution or any underlying arrangement, directly or indirectly, secure or provide for the payment of more than 10 percent of the debt service on the Bonds, in contravention of section 141(b)(2) of the Code;

(ii) to take any action to assure that in the event that the "private business use" described in subsection (a)(i) hereof exceeds 5 percent of the proceeds of the Bonds or the projects financed therewith (less amounts deposited into a reserve fund, if any) then the amount in excess of 5 percent is used for a "private business use" which is "related" and not "disproportionate," within the meaning of section 141(b)(3) of the Code, to the governmental use;

(iii) to take any action to assure that no amount which is greater than the lesser of \$5,000,000, or 5 percent of the proceeds of the Bonds (less amounts deposited into a reserve fund, if any) is directly or indirectly used to finance loans to persons, other than state or local governmental units, in contravention of section 141(c) of the Code;

(iv) to refrain from taking any action which would otherwise result in the Bonds being treated as "private activity bonds" within the meaning of section 141(b) of the Code;

(v) to refrain from taking any action that would result in the Bonds being "federally guaranteed" within the meaning of section 149(b) of the Code;

(vi) to refrain from using any portion of the proceeds of the Bonds, directly or indirectly, to acquire or to replace funds which were used, directly or indirectly, to acquire investment property (as defined in section 148(b)(2) of the Code) which produces a materially higher yield over the term of the Bonds, other than investment property acquired with:

(A) proceeds of the Bonds invested for a reasonable temporary period of 3 years or less or, in the case of a refunding bond, for a period of 90 days or less until such proceeds are needed for the purpose for which the Bonds are issued,

(B) amounts invested in a bona fide debt service fund, within the meaning of section 1.148 1(b) of the Treasury Regulations, and

(C) amounts deposited in any reasonably required reserve or replacement fund to the extent such amounts do not exceed 10 percent of the proceeds of the Bonds;

(vii) to otherwise restrict the use of the proceeds of the Bonds or amounts treated as proceeds of the Bonds, as may be necessary, so that the Bonds do not otherwise contravene the requirements of section 148 of the Code (relating to arbitrage); and

(viii) to pay to the United States of America at least once during each five-year period (beginning on the date of delivery of the Bonds) an amount that is at least equal to 90 percent of the "Excess Earnings" (within the meaning of section 148(f) of the Code) and to pay to the United States of America, not later than 60 days after the Bonds have been paid in full, 100 percent of the amount then required to be paid as a result of Excess Earnings under section 148(f) of the Code.

(b) *Rebate Fund.* In order to facilitate compliance with subsection (a)(viii), a "Rebate Fund" is hereby established by the Issuer for the sole benefit of the United States of America, and such fund shall not be subject to the claim of any other person, including without limitation the Registered Owners. The Rebate Fund is established for the additional purpose of compliance with section 148 of the Code.

(c) *Proceeds.* The Issuer understands that the term "proceeds" includes "disposition proceeds" as defined in the Treasury Regulations and, in the case of refunding bonds, transferred proceeds (if any) and proceeds of refunded obligations expended prior to the date of issuance of the Bonds. It is the understanding of the Issuer that the covenants contained herein are intended to assure compliance with the Code and any regulations or rulings promulgated by the U.S. Department of the Treasury pursuant thereto. In the event that regulations or rulings are hereafter promulgated which modify or expand provisions of the Code, as applicable to the Bonds, the Issuer will not be required to comply with any covenant contained herein to the extent that such failure to comply, in the opinion of nationally recognized bond counsel, will not adversely affect the exemption from federal income taxation of interest on the Bonds under section 103 of the Code. In the event that regulations or rulings are hereafter promulgated which impose additional requirements which are applicable to the Bonds, the Issuer agrees to comply with the additional requirements to the extent necessary, in the opinion of nationally recognized bond counsel, to preserve the exemption from federal income taxation of interest on the Bonds under section 103 of the Code. In furtherance of such intention, the Issuer hereby authorizes and directs the City Manager or Chief Financial Officer to execute any documents, certificates or reports required by the Code and to make such elections, on behalf of the Issuer, which may be permitted by the Code as are consistent with the purpose for the issuance of the Bonds. This section shall apply only to the Bonds.

**Section 9. DISPOSITION OF PROJECT.** The Issuer covenants that the property financed with the proceeds of the Bonds will not be sold or otherwise disposed in a transaction resulting in the receipt by the Issuer of cash or other compensation, unless the Issuer obtains an opinion of nationally recognized bond counsel that such sale or other disposition will not adversely affect the tax-exempt status of such Bonds. For purposes of the foregoing, the portion of the property comprising personal property and disposed in the ordinary course shall not be treated as a transaction resulting in the receipt of cash or other compensation. For purposes hereof, the Issuer shall not be obligated to comply with this covenant if it obtains an opinion that such failure to comply will not adversely affect the excludability for federal income tax purposes from gross income of the interest. This section shall apply only to the Bonds.

**Section 10. ALLOCATION OF, AND LIMITATION ON, EXPENDITURES FOR THE PROJECT.** The Issuer covenants to account for the expenditure of sale proceeds and investment earnings to be used for the construction and acquisition of the Project on its books and records by allocating proceeds

to expenditures within 18 months of the later of the date that (1) the expenditure is made, or (2) the Project is completed. The foregoing notwithstanding, the Issuer shall not expend sale proceeds or investment earnings thereon more than 60 days after the earlier of (1) the fifth anniversary of the delivery of the Bonds, or (2) the date the Bonds are retired, unless the Issuer obtains an opinion of nationally-recognized bond counsel that such expenditure will not adversely affect the status, for federal income tax purposes, of the Bonds or the interest thereon. For purposes hereof, the Issuer shall not be obligated to comply with this covenant if it obtains an opinion that such failure to comply will not adversely affect the excludability for federal income tax purposes from gross income of the interest. This section shall apply only to the Bonds.

**Section 11. Reserved.**

**Section 12. CUSTODY, APPROVAL, AND REGISTRATION OF BONDS.** The City Manager or the Chief Financial Officer of the City is hereby authorized to have control of the Bonds initially issued and delivered hereunder and all necessary records and proceedings pertaining to the Bonds pending their delivery and their investigation, examination, and approval by the Attorney General of the State of Texas, and their registration by the Comptroller of Public Accounts of the State of Texas. Upon registration of the Bonds said Comptroller of Public Accounts (or a deputy designated in writing to act for said Comptroller) shall manually sign the Comptroller's Registration Certificate attached to such Bonds, and the seal of said Comptroller shall be impressed, or placed in facsimile, on such certificate. The Bonds thus registered shall remain in the custody of the Chief Financial Officer (or the designee thereof) until delivered to the Purchaser (as defined in Section 16 of this Ordinance).

**Section 13. DTC REGISTRATION.** The Bonds initially shall be issued and delivered in such manner that no physical distribution of the Bonds will be made to the public, and The Depository Trust Company ("DTC"), New York, New York, initially will act as depository for the Bonds. DTC has represented that it is a limited purpose trust company incorporated under the laws of the State of New York, a member of the Federal Reserve System, a "clearing corporation" within the meaning of the New York Uniform Commercial Code, and a "clearing agency" registered under Section 17A of the Securities Exchange Act of 1934, as amended, and the City accepts, but in no way verifies, such representations. The Bonds initially authorized by this Ordinance shall be delivered to and registered in the name of CEDE & CO., the nominee of DTC. It is expected that DTC will hold the Bonds on behalf of the Purchaser and its participants. So long as each Bond is registered in the name of CEDE & CO., the Paying Agent/Registrar shall treat and deal with DTC the same in all respects as if it were the actual and beneficial owner thereof. It is expected that DTC will maintain a book-entry system which will identify ownership of the Bonds in Authorized Denominations, with transfers of ownership being effected on the records of DTC and its participants pursuant to rules and regulations established by them, and that the Bonds initially deposited with DTC shall be immobilized and not be further exchanged for substitute Bonds except as hereinafter provided. The City is not responsible or liable for any functions of DTC, will not be responsible for paying any fees or charges with respect to its services, will not be responsible or liable for maintaining, supervising, or reviewing the records of DTC or its participants, or protecting any interests or rights of the beneficial owners of the Bonds. It shall be the duty of the DTC Participants, as defined in the Official Statement herein approved, to make all arrangements with DTC to establish this book-entry system, the beneficial ownership of the Bonds, and the method of paying the fees and charges of DTC. The City does not represent, nor does it in any way covenant that the initial book-entry system established with DTC will be maintained in the future. Notwithstanding the initial establishment of the foregoing book-entry system with DTC, if for any reason any of the originally delivered Bonds is duly filed with the Paying Agent/Registrar with proper request for transfer and substitution, as provided for in this Ordinance, substitute Bonds will be duly delivered as provided in this Ordinance, and there will be no assurance or representation that any book-entry system will be maintained for such Bonds. In connection with the initial establishment of the foregoing book-entry system with DTC, the City heretofore has executed a "Blanket Letter of Representations" prepared by DTC in order to implement the book-entry system described above.

**Section 14. CONTINUING DISCLOSURE OBLIGATION PURSUANT TO RULE 15C2-12 (17 C.F.R. § 240.15C2-12).**

(a) *Annual Reports.*

(i) The City will provide certain updated financial information and operating data to the MSRB on an annual basis in an electronic format that is prescribed by the MSRB and available via the Electronic Municipal Market Access System ("EMMA") at [www.emma.msrb.org](http://www.emma.msrb.org). The information to be updated includes all quantitative financial information and operating data with respect to the City of the general type included in the Official Statement under Tables numbered [-] and in Appendix B (or as otherwise provided in the Pricing Certificate). The City will update and provide the information in Tables [-] within six months after the end of each fiscal year ending in and after 2026. The City will additionally provide audited financial statements when and if available, and in any event, within 12 months after the end of each fiscal year ending in or after 2026. If the audit of such financial statements is not complete within 12 months after any such fiscal year end, then the City will file unaudited financial statements within such 12-month period and audited financial statements for the applicable fiscal year, when and if the audit report on such statements becomes available. Any such financial statements will be prepared in accordance with the accounting principles described in Appendix B of the Official Statement or such other accounting principles as the City may be required to employ from time to time pursuant to State law or regulation.

(ii) The financial information and operating data to be provided may be set forth in full in one or more documents or may be included by specific reference to any document available to the public on the MSRB's Internet Web site or filed with the SEC, as permitted by the Rule. If the City changes its fiscal year, it will notify the MSRB of the change (and of the date of the new fiscal year end) prior to the next date by which the City otherwise would be required to provide financial information and operating data pursuant to this Section. The financial information and operating data to be provided pursuant to this Section may be set forth in full in one or more documents or may be included by specific reference to any document that is available to the public on the MSRB's internet website or filed with the SEC. All documents provided to the MSRB pursuant to this Section shall be accompanied by identifying information as prescribed by the MSRB.

(b) *Event Notices.* The City shall notify the MSRB in an electronic format as prescribed by the MSRB, in a timely manner (but not in excess of ten Business Days after the occurrence of the event) of any of the following events with respect to the Bonds:

1. Principal and interest payment delinquencies;
2. Non-payment related defaults, if material;
3. Unscheduled draws on debt service reserves reflecting financial difficulties;
4. Unscheduled draws on credit enhancements reflecting financial difficulties;
5. Substitution of credit or liquidity providers, or their failure to perform;
6. Adverse tax opinions or the issuance by the Internal Revenue Service of proposed or final determinations of taxability, Notices of Proposed Issue (IRS Form 5701-TEB) or other material notices or determinations with respect to the tax status of the Bonds, or other material events affecting the tax status of the Bonds;

7. Modifications to rights of Bondholders, if material;
8. Bond calls, if material, and tender offers;
9. Defeasances;
10. Release, substitution, or sale of property securing repayment of the Bonds, if material;
11. Rating changes;
12. Bankruptcy, insolvency, receivership or similar event of an obligated person (which is considered to occur when any of the following occur: the appointment of a receiver, fiscal agent, or similar officer for the City in a proceeding under the United States Bankruptcy Code or in any other proceeding under state or federal law in which a court or governmental authority has assumed jurisdiction over substantially all of the assets or business of the City, or if such jurisdiction has been assumed by leaving the existing governing body and officials or officers in possession but subject to the supervision and orders of a court or governmental authority, or the entry of an order confirming a plan of reorganization, arrangement, or liquidation by a court or governmental authority having supervision or jurisdiction over substantially all of the assets or business of the City);
13. The consummation of a merger, consolidation, or acquisition involving an obligated person or the sale of all or substantially all of the assets of the obligated person, other than in the ordinary course of business, the entry into a definitive agreement to undertake such an action or the termination of a definitive agreement relating to any such actions, other than pursuant to its terms, if material;
14. Appointment of a successor or additional trustee or the change of name of a trustee, if material;
15. Incurrence of a Financial Obligation of the City, if material, or agreement to covenants, events of default, remedies, priority rights, or other similar terms of a Financial Obligation of the City, any of which affect Bondholders, if material; and
16. Default, event of acceleration, termination event, modification of terms, or other similar events under the terms of a Financial Obligation of the City, any of which reflect financial difficulties.

The City shall notify the MSRB, in a timely manner, of any failure by the City to provide financial information or operating data in accordance with this Section by the time required by such subsection.

*(c) Limitations, Disclaimers, and Amendments.*

(i) The City shall be obligated to observe and perform the covenants specified in this Section for so long as, but only for so long as, the City remains an "obligated person" with respect to the Bonds within the meaning of the Rule, except that the City in any event will give notice of any deposit made in accordance with this Ordinance or applicable law that causes Bonds no longer to be outstanding.

(ii) The provisions of this Section are for the sole benefit of the registered owners and beneficial owners of the Bonds, and nothing in this Section, express or implied, shall give any

benefit or any legal or equitable right, remedy, or claim hereunder to any other person. The City undertakes to provide only the financial information, operating data, financial statements, and notices which it has expressly agreed to provide pursuant to this Section and does not hereby undertake to provide any other information that may be relevant or material to a complete presentation of the City's financial results, condition, or prospects or hereby undertake to update any information provided in accordance with this Section or otherwise, except as expressly provided herein. The City does not make any representation or warranty concerning such information or its usefulness to a decision to invest in or sell Bonds at any future date.

(iii) UNDER NO CIRCUMSTANCE SHALL THE CITY BE LIABLE TO THE REGISTERED OWNER OR BENEFICIAL OWNER OF ANY BOND OR ANY OTHER PERSON, IN CONTRACT OR TORT, FOR DAMAGES RESULTING IN WHOLE OR IN PART FROM ANY BREACH BY THE CITY, WHETHER NEGLIGENT OR WITHOUT FAULT ON ITS PART, OF ANY COVENANT SPECIFIED IN THIS SECTION, BUT EVERY RIGHT AND REMEDY OF ANY SUCH PERSON, IN CONTRACT OR TORT, FOR OR ON ACCOUNT OF ANY SUCH BREACH SHALL BE LIMITED TO AN ACTION FOR MANDAMUS OR SPECIFIC PERFORMANCE.

(iv) No default by the City in observing or performing its obligations under this Section shall comprise a breach of or default under this Ordinance for purposes of any other provision of this Ordinance. Nothing in this Section is intended or shall act to disclaim, waive, or otherwise limit the duties of the City under federal and state securities laws.

(v) Should the Rule be amended to obligate the City to make filings with or provide notices to entities other than the MSRB, the City hereby agrees to undertake such obligation with respect to the Bonds in accordance with the Rule as amended. The provisions of this Section may be amended by the City from time to time to adapt to changed circumstances that arise from a change in legal requirements, a change in law, or a change in the identity, nature, status, or type of operations of the City, but only if (1) the provisions of this Section, as so amended, would have permitted an underwriter to purchase or sell Bonds in the primary offering of the Bonds in compliance with the Rule, taking into account any amendments or interpretations of the Rule since such offering as well as such changed circumstances and (2) either (a) the registered owners of a majority in aggregate principal amount (or any greater amount required by any other provision of this Ordinance that authorizes such an amendment) of the outstanding Bonds consent to such amendment or (b) a person that is unaffiliated with the City (such as nationally recognized bond counsel) determined that such amendment will not materially impair the interest of the registered owners and beneficial owners of the Bonds. If the City so amends the provisions of this Section, it shall include with any amended financial information or operating data next provided in accordance with subsection (b) of this Section an explanation, in narrative form, of the reason for the amendment and of the impact of any change in the type of financial information or operating data so provided. The City may also amend or repeal the provisions of this continuing disclosure agreement if the SEC amends or repeals the applicable provision of the Rule or a court of final jurisdiction enters judgment that such provisions of the Rule are invalid, but only if and to the extent that the provisions of this sentence would not prevent an underwriter from lawfully purchasing or selling Bonds in the primary offering of the Bonds.

#### **Section 15. DEFEASANCE.**

(a) *Deemed Paid.* Any Bond and the interest thereon shall be deemed to be paid, retired and no longer outstanding (a "Defeased Bond") within the meaning of this Ordinance, except to the extent provided in subsection (e) of this Section, when payment of the principal of such Bond, plus interest thereon to the

due date (whether such due date be by reason of maturity or otherwise) either (i) shall have been made or caused to be made in accordance with the terms thereof, or (ii) shall have been provided for on or before such due date by irrevocably depositing with or making available to the Paying Agent/Registrar in accordance with an escrow agreement or other instrument (the "Future Escrow Agreement") for such payment (1) lawful money of the United States of America sufficient to make such payment or (2) Defeasance Securities that mature as to principal and interest in such amounts and at such times as will insure the availability, without reinvestment, of sufficient money to provide for such payment, and when proper arrangements have been made by the City with the Paying Agent/Registrar for the payment of its services until all Defeased Bonds shall have become due and payable. At such time as a Bond shall be deemed to be a Defeased Bond hereunder, as aforesaid, such Bond and the interest thereon shall no longer be secured by, payable from, or entitled to the benefits of, the ad valorem taxes herein levied and pledged as provided in this Ordinance, and such principal and interest shall be payable solely from such money or Defeasance Securities.

(b) *Investments.* Any moneys so deposited with the Paying Agent/Registrar may at the written direction of the City be invested in Defeasance Securities, maturing in the amounts and times as hereinbefore set forth, and all income from such Defeasance Securities received by the Paying Agent/Registrar that is not required for the payment of the Bonds and interest thereon, with respect to which such money has been so deposited, shall be turned over to the City, or deposited as directed in writing by the City. Any Future Escrow Agreement pursuant to which the money and/or Defeasance Securities are held for the payment of Defeased Bonds may contain provisions permitting the investment or reinvestment of such moneys in Defeasance Securities or the substitution of other Defeasance Securities upon the satisfaction of the requirements specified in subsection (a)(i) or (ii) above. All income from such Defeasance Securities received by the Paying Agent/Registrar which is not required for the payment of the Defeased Securities, with respect to which such money has been so deposited, shall be remitted to the City or deposited as directed in writing by the City.

(c) *Selection of Defeased Bonds.* In the event that the City elects to defease less than all of the principal amount of Bonds of a maturity, the Paying Agent/Registrar shall select, or cause to be selected, such amount of Bonds by such random method as it deems fair and appropriate.

(d) *Defeasance Securities.* The term "Defeasance Securities" means (i) direct, noncallable obligations of the United States of America, including obligations that are unconditionally guaranteed by the United States of America, (ii) noncallable obligations of an agency or instrumentality of the United States, including obligations that are unconditionally guaranteed or insured by the agency or instrumentality and that, on the date the governing body of the City adopts or approves the proceedings authorizing the issuance of refunding bonds, are rated as to investment quality by a nationally recognized investment rating firm not less than AAA or its equivalent; (iii) noncallable obligations of a state or an agency or a county, municipality, or other political subdivision of a state that have been refunded and that, on the date the governing body of the City adopts or approves the proceedings authorizing the issuance of refunding bonds, are rated as to investment quality by a nationally recognized investment rating firm not less than AAA or its equivalent and (iv) any securities and obligations now or hereafter authorized by State law that are eligible to refund, retire or otherwise discharge obligations such as the Bonds.

(e) The Pricing Officer is authorized to modify the categories of Defeasance Securities that are eligible to defease the Bonds.

(f) *Continuing Duty of Paying Agent/Registrar.* Until all Bonds defeased under this Section of this Ordinance shall become due and payable, the Paying Agent/Registrar for such Bonds shall perform the services of Paying Agent/Registrar for such Bonds the same as if they had not been defeased, and the City shall make proper arrangements to provide and pay for such services.

**Section 16. SALE OF BONDS; OFFICIAL STATEMENT.**

(a) The Bonds may be sold by public offering (either through a negotiated or competitive offering) and the terms and provisions of which are to be determined by the Pricing Officer in accordance with Section 2 hereof, and in which the purchasers of the Bonds are designated. The Bonds may be sold pursuant to a purchase agreement or notice of sale and bidding instructions (collectively, the "Purchase Agreement") which the Pricing Officer is hereby authorized to execute and deliver and in which the Purchaser of the Bonds shall be designated. The Bonds shall initially be registered in the name of the Purchaser thereof as set forth in the Pricing Certificate.

(b) The City hereby deems final and approves the form and content of the draft preliminary official statement relating to the Bonds and any addenda, supplement or amendment thereto, and approves the distribution of such preliminary official statement in the reoffering of the Bonds by the Purchaser in final form, with such changes therein or additions thereto as the Pricing Officer executing the same may deem advisable. The Pricing Officer is hereby authorized, in the name and on behalf of the City, to approve, distribute, and deliver a final preliminary official statement and a final official statement relating to the Bonds to be used by the Purchaser in the marketing of the Bonds.

(c) The Pricing Officer is authorized, in connection with effecting the sale of the Bonds, to obtain from a municipal bond insurance company so designated in the Pricing Certificate (the "Insurer") a municipal bond insurance policy (the "Insurance Policy") in support of the Bonds. To that end, should the Pricing Officer exercise such authority and commit the City to obtain a municipal bond insurance policy, for so long as the Insurance Policy is in effect, the requirements of the Insurer relating to the issuance of the Insurance Policy are incorporated by reference into this Ordinance and made a part hereof for all purposes, notwithstanding any other provision of this Ordinance to the contrary. The Pricing Officer shall have the authority to execute any documents to effect the issuance of the Insurance Policy by the Insurer.

(d) The Mayor and Mayor Pro Tem, the City Manager, the Chief Financial Officer and City Secretary, shall be and they are hereby expressly authorized, empowered and directed from time to time and at any time to do and perform all such acts and things and to execute, acknowledge and deliver in the name and under the corporate seal and on behalf of the City a Paying Agent/Registrar Agreement, in the form presented at the meeting at which this Ordinance is adopted, with the Paying Agent/Registrar and all other instruments, whether or not herein mentioned, as may be necessary or desirable in order to carry out the terms and provisions of this Ordinance, the Bonds, the sale of the Bonds, the Purchase Agreement and the Official Statement. In case any officer whose signature shall appear on any Bond shall cease to be such officer before the delivery of such Bond, such signature shall nevertheless be valid and sufficient for all purposes the same as if such officer had remained in office until such delivery.

**Section 17. FURTHER PROCEDURES.** The Mayor, the City Secretary, the City Manager, and Chief Financial Officer, shall be and they are hereby expressly authorized, empowered, and directed from time to time and at any time to do and perform all such acts and things and to execute, acknowledge, and deliver in the name and under the corporate seal and on behalf of the City all such instruments, whether or not herein mentioned, as may be necessary or desirable in order to carry out the terms and provisions of this Ordinance, and the sale and delivery of the Bonds and fixing all details in connection therewith. The City Council hereby authorizes the payment of the fee of the Office of the Attorney General of the State of Texas for the examination of the proceedings relating to the issuance of the Bonds, in the amount determined in accordance with the provisions of Section 1202.004, Texas Government Code.

**Section 18. CONSTRUCTION FUND; USE OF PROCEEDS.**

(a) The City hereby creates and establishes and shall maintain on the books of the City a separate fund to be entitled the "Series 2026 GO Bonds Construction Fund" (the "Construction Fund") for use by

the City for payment of all lawful costs associated with the acquisition and construction of the projects as provided in Section 1.

(b) The proceeds from the sale of the Bonds shall be deposited, on the date of closing, in the manner described in a letter of instructions prepared by the City or on behalf of the City by the City's financial advisor. The foregoing notwithstanding, any proceeds representing accrued interest on the Bonds shall be deposited to the credit of the Interest and Sinking Fund.

**Section 19. INTEREST EARNINGS.** The interest earnings derived from the investment of proceeds from the sale of the Bonds may be used along with other proceeds for the construction of the permanent improvements set forth in Section 1 hereof for which the Bonds are issued; provided that after completion of such permanent improvements, if any of such interest earnings remain on hand, such interest earnings shall be deposited in the Interest and Sinking Fund. It is further provided, however, that any interest earnings on proceeds which are required to be rebated to the United States of America pursuant to this Ordinance hereof in order to prevent the Bonds from being arbitrage bonds shall be so rebated and not considered as interest earnings for the purposes of this Section.

**Section 20. DEFAULT AND REMEDIES.**

(a) *Events of Default.* Each of the following occurrences or events for the purpose of this Ordinance is hereby declared to be an Event of Default: (i) the failure to make payment of the principal of or interest on any of the Bonds when the same becomes due and payable or (ii) default in the performance or observance of any other covenant, agreement or obligation of the City, the failure to perform which materially, adversely affects the rights of the registered owners of the Bonds, including, but not limited to, their prospect or ability to be repaid in accordance with this Ordinance, and the continuation thereof for a period of 60 days after notice of such default is given by any registered owner to the City.

(b) *Remedies for Default.* Upon the happening of any Event of Default, then and in every case, any registered owner or an authorized representative thereof, including, but not limited to, a trustee or trustees therefor, may proceed against the City, or any official, officer or employee of the City in their official capacity, for the purpose of protecting and enforcing the rights of the registered owners under this Ordinance, by mandamus or other suit, action or special proceeding in equity or at law, in any court of competent jurisdiction, for any relief permitted by law, including the specific performance of any covenant or agreement contained herein, or thereby to enjoin any act or thing that may be unlawful or in violation of any right of the registered owners hereunder or any combination of such remedies. It is provided that all such proceedings shall be instituted and maintained for the equal benefit of all registered owners of Bonds then outstanding.

(c) *Remedies Not Exclusive.*

(i) No remedy herein conferred or reserved is intended to be exclusive of any other available remedy or remedies, but each and every such remedy shall be cumulative and shall be in addition to every other remedy given hereunder or under the Bonds or now or hereafter existing at law or in equity; provided, however, that notwithstanding any other provision of this Ordinance, the right to accelerate the debt evidenced by the Bonds shall not be available as a remedy under this Ordinance.

(ii) The exercise of any remedy herein conferred or reserved shall not be deemed a waiver of any other available remedy.

(iii) By accepting the delivery of a Bond authorized under this Ordinance, such registered owner agrees that the certifications required to effectuate any covenants or representations

contained in this Ordinance do not and shall never constitute or give rise to a personal or pecuniary liability or charge against the officers, employees or members of the City or the City Council.

(iv) None of the members of the City Council, nor any other official or officer, agent, or employee of the City, shall be charged personally by the registered owners with any liability, or be held personally liable to the registered owners under any term or provision of this Ordinance, or because of any Event of Default or alleged Event of Default under this Ordinance.

## **Section 21. MISCELLANEOUS PROVISIONS.**

(a) *Preamble.* The preamble to this Ordinance is incorporated by reference and made a part hereof for all purposes.

(b) *Titles Not Restrictive.* The titles assigned to the various sections of this Ordinance are for convenience only and shall not be considered restrictive of the subject matter of any section or of any part of this Ordinance.

(c) *Rules of Construction.* The words "herein", "hereof" and "hereunder" and other words of similar import refer to this Ordinance as a whole and not to any particular section or other subdivision. Except where the context otherwise requires, terms defined in this Ordinance to impart the singular number shall be considered to include the plural number and vice versa. References to any named person means that party and its successors and assigns. References to any constitutional, statutory or regulatory provision means such provision as it exists on the date this Ordinance is adopted by the City and any future amendments thereto or successor provisions thereof. Any reference to "FORM OF BOND" shall refer to the form of the Bonds set forth in **Exhibit A** to this Ordinance. Any reference to the payment of principal in this Ordinance shall be deemed to include the payment of any mandatory sinking fund redemption payments as may be described herein.

(d) *Inconsistent Provisions.* All ordinances, orders and resolutions, or parts thereof, which are in conflict or inconsistent with any provision of this Ordinance are hereby repealed and declared to be inapplicable, and the provisions of this Ordinance shall be and remain controlling as to the matters prescribed herein.

(e) *Severability.* If any word, phrase, clause, paragraph, sentence, part, portion, or provision of this Ordinance or the application thereof to any person or circumstance shall be held to be invalid, the remainder of this Ordinance shall nevertheless be valid and the City hereby declares that this Ordinance would have been enacted without such invalid word, phrase, clause, paragraph, sentence, part, portion, or provisions.

(f) *Governing Law.* This Ordinance shall be construed and enforced in accordance with the laws of the State of Texas.

(g) *Open Meeting.* The City officially finds and determines that the meeting at which this Ordinance is adopted was open to the public; and that public notice of the time, place, and purpose of such meeting was given, all as required by Chapter 551, Texas Government Code.

(h) *Immediate Effect.* In accordance with the provisions of Section 1201.028, Texas Government Code, this Ordinance shall be effective immediately upon its adoption by the City Council.

SCHEDULE I – SCHEDULE OF VOTED BOND AUTHORIZATION

*(Prior to the issuance of the 2026 Bonds. The use of the below voted authorization, following pricing of the 2026 Bonds, shall be reflected in the Pricing Certificate executed by the Pricing Officer.)*

MAY 4, 2019 ELECTION			
Purpose	Amount Authorized	Amount Previously Issued	Unissued Balance
Public safety facilities (Prop A)	\$62,500,000	\$47,500,000	\$15,000,000
Parks & Recreational (Prop E)	\$53,500,000	\$35,700,000	\$17,800,000

MAY 6, 2026 ELECTION			
Purpose	Amount Authorized	Amount Previously Issued	Unissued Balance
Public safety facilities (Prop A)	\$131,400,000	\$0	\$131,400,000
Streets & Roads (Prop B)	\$240,000,000	\$30,800,000	\$209,200,000
Parks Operation Facility (Prop C)	\$39,000,000	\$0	\$39,000,000
Parks and Recreational (Prop D)	\$43,000,000	\$5,000,000	\$38,000,000
Downtown Garage (Prop E)	\$20,000,000	\$2,000,000	\$18,000,000

EXHIBIT A

FORM OF BOND

The form of the Bonds, including the form of Paying Agent/Registrar's Authentication Certificate, the form of Assignment and the form of Registration Certificate of the Comptroller of Public Accounts of the State of Texas to be attached only to the Bonds initially issued and delivered pursuant to this Ordinance, shall be, respectively, substantially as follows, with such appropriate variations, omissions, or insertions as are permitted or required by this Ordinance and with the Bonds to be completed with information set forth in the Pricing Certificate. The Form of Bond as it appears in this **Exhibit A** shall be completed, amended and modified by Bond Counsel to incorporate the information set forth in the Pricing Certificate but it is not required for the Form of Bond to reproduced as an exhibit to the Pricing Certificate.

*The "[ - ]" in this section are intentional.*

NO. [R][T]-1

UNITED STATES OF AMERICA  
STATE OF TEXAS  
COUNTIES OF TARRANT AND DENTON

PRINCIPAL  
AMOUNT  
\$ \_\_\_\_\_

CITY OF ROANOKE, TEXAS  
GENERAL OBLIGATION BOND, SERIES 2026

<u>MATURITY DATE</u> _____	<u>INTEREST RATE</u> _____	<u>DELIVERY DATE</u> _____, 2026	<u>CUSIP NO.</u> _____
-------------------------------	-------------------------------	-------------------------------------	---------------------------

REGISTERED OWNER:

PRINCIPAL AMOUNT:

ON THE MATURITY DATE SPECIFIED ABOVE, THE CITY OF ROANOKE, TEXAS, in Tarrant and Denton Counties (the "City"), being a political subdivision of the State of Texas, hereby promises to pay to the Registered Owner specified above or to the registered assignee hereof (either being hereinafter called the "registered owner") the Principal Amount specified above, and to pay interest thereon (calculated on the basis of a 360-day year of twelve 30-day months), from the Delivery Date specified above, to the Maturity Date specified above, or the date of its redemption prior to scheduled maturity, at the interest rate per annum specified above, with said interest payable on [February/August]15, 202[ ], and semiannually on each August 15 and February 15 thereafter until maturity or prior redemption; except that if this Bond is required to be authenticated and the date of its authentication is later than [February/August] 15, 202[ ], such interest is payable semiannually on each August 15 and February 15 following such date.

THE PRINCIPAL OF AND INTEREST ON this Bond are payable in lawful money of the United States of America, without exchange or collection charges. At maturity or redemption prior to maturity, the principal of this Bond shall be paid to the registered owner hereof upon presentation and surrender of this Bond at the designated corporate trust office in Dallas, Texas (the "Designated Trust Office") of U.S. Bank Trust Company, National Association, which is the "Paying Agent/Registrar" for this Bond. The payment of interest on this Bond shall be made by the Paying Agent/Registrar to the registered owner hereof on each interest payment date by check, dated as of such interest payment date, drawn by the Paying Agent/Registrar on, and payable solely from, funds of the City required by the ordinance authorizing the issuance of this Bond (the "Bond Ordinance") to be on deposit with the Paying Agent/Registrar for such

purpose as hereinafter provided; and such check shall be sent by the Paying Agent/Registrar by United States mail, first-class postage prepaid, on each such interest payment date, to the registered owner hereof, at its address as it appeared on the last business day of the month preceding each such date (the "Record Date") on the Registration Books kept by the Paying Agent/Registrar, as hereinafter described. Any accrued interest due at maturity as provided herein shall be paid to the registered owner upon presentation and surrender of this Bond for payment at the Designated Trust Office of the Paying Agent/Registrar. The City covenants with the registered owner of this Bond that on or before each principal and interest payment date for this Bond it will make available to the Paying Agent/Registrar, from the "Interest and Sinking Fund" created by the Bond Ordinance, the amounts required to provide for the payment, in immediately available funds, of all principal of and interest on the Bonds, when due.

IN THE EVENT OF NON-PAYMENT of interest on a scheduled payment date, and for thirty days thereafter, a new record date for such interest payment (a "Special Record Date") will be established by the Paying Agent/Registrar, if and when funds for the payment of such interest have been received from the City. Notice of the Special Record Date and of the scheduled payment date of the past due interest ("Special Payment Date", which shall be 15 days after the Special Record Date) shall be sent at least five business days prior to the Special Record Date by United States mail, first-class postage prepaid, to the address of each registered owner of a Bond appearing on the Registration Books kept by the Paying Agent/Registrar at the close of business on the last business day next preceding the date of mailing of such notice.

IF THE DATE for the payment of the principal of or interest on this Bond shall be a Saturday, Sunday, a legal holiday, or a day on which banking institutions in the city where the Designated Trust Office of the Paying Agent/Registrar is located are authorized by law or executive order to close, then the date for such payment shall be the next succeeding day which is not such a Saturday, Sunday, legal holiday, or day on which banking institutions are authorized to close; and payment on such date shall have the same force and effect as if made on the original date payment was due.

THIS BOND is one of a Series of Bonds dated as of [--], 2026, authorized in accordance with the Constitution and laws of the State of Texas in the principal amount of \$[-], for the following public purposes: (i) designing, constructing and equipping a convention center facility consisting of conference and meeting rooms, ballrooms, and gathering space that is to be in proximity to and integrated with a full-service convention center hotel and to be leased to a private operator for such purposes and (ii) paying costs of issuance of the Bonds (collectively, the "Projects").

ON FEBRUARY 15, 203[-], or on any date thereafter, the Bonds of this Series maturing on [February/August] 15, 203[-] and thereafter may be redeemed prior to their scheduled maturities, at the option of the City, in whole, or in part, at par and accrued interest to the date fixed for redemption. The years of maturity of the Bonds called for redemption at the option of the City prior to their stated maturity shall be selected by the City. The Bonds or portions thereof redeemed within a maturity shall be selected by lot or other method by the Paying Agent/Registrar; provided, that during any period in which ownership of the Bonds is determined only by a book entry at a securities depository for the Bonds, if fewer than all of the Bonds of the same maturity and bearing the same interest rate are to be redeemed, the particular Bonds of such maturity and bearing such interest rate shall be selected in accordance with the arrangements between the City and the securities depository.

THE BONDS SCHEDULED TO MATURE ON [FEBRUARY/AUGUST] 15, 20[-] (the "*Term Bonds*") are subject to scheduled mandatory redemption by the Paying Agent/Registrar by lot, or by any other customary method that results in a random selection, at a price equal to the principal amount thereof, plus accrued interest to the redemption date, out of moneys available for such purpose in the interest and sinking fund for the Bonds, on each [February/August] 15 of the years and in the respective principal amounts, set forth in the following schedule:

Term Bonds due [February/August] 15, 20[-]

Mandatory Redemption Date: /15/20	Principal Amount: \$,000
Mandatory Redemption Date: /15/20	Principal Amount: \$,000
Mandatory Redemption Date: /15/20*	Principal Amount: \$,000

\* Stated Maturity

THE PRINCIPAL AMOUNT OF THE TERM BONDS of a stated maturity required to be redeemed on any mandatory redemption date pursuant to the operation of the mandatory sinking fund redemption provisions shall be reduced, at the option of the Issuer, by the principal amount of any Term Bonds of the same maturity which, at least 50 days prior to a mandatory redemption date (1) shall have been acquired by the Issuer at a price not exceeding the principal amount of such Term Bonds plus accrued interest to the date of purchase thereof, and delivered to the Paying Agent/Registrar for cancellation, (2) shall have been purchased and canceled by the Paying Agent/Registrar at the request of the Issuer at a price not exceeding the principal amount of such Term Bonds plus accrued interest to the date of purchase, or (3) shall have been redeemed pursuant to the optional redemption provisions and not theretofore credited against a mandatory redemption requirement.]

AT LEAST THIRTY days prior to the date fixed for any such redemption, a written notice of such redemption shall be given to the registered owner of each Bond or a portion thereof being called for redemption by depositing such notice in the United States mail, first-class postage prepaid, addressed to each such registered owner at his address shown on the Registration Books of the Paying Agent/Registrar. By the date fixed for any such redemption due provision shall be made by the City with the Paying Agent/Registrar for the payment of the required redemption price for this Bond or the portion hereof which is to be so redeemed, plus accrued interest thereon to the date fixed for redemption. If such notice of redemption is given, and if due provision for such payment is made, all as provided above, this Bond, or the portion hereof which is to be so redeemed, thereby automatically shall be redeemed prior to its scheduled maturity, and shall not bear interest after the date fixed for its redemption, and shall not be regarded as being outstanding except for the right of the registered owner to receive the redemption price plus accrued interest to the date fixed for redemption from the Paying Agent/Registrar out of the funds provided for such payment. The Paying Agent/Registrar shall record in the Registration Books all such redemptions of principal of this Bond or any portion hereof. If a portion of any Bond shall be redeemed a substitute Bond or Bonds having the same maturity date, bearing interest at the same rate, in Authorized Denominations, at the written request of the registered owner, and in aggregate principal amount equal to the unredeemed portion thereof, will be issued to the registered owner upon the surrender thereof for cancellation, at the expense of the City, all as provided in the Ordinance.

IF AT THE TIME OF MAILING of notice of optional redemption there shall not have either been deposited with the Paying Agent/Registrar or legally authorized escrow agent immediately available funds sufficient to redeem all the Bonds called for redemption, such notice must state that it is conditional, and is subject to the deposit of the redemption moneys with the Paying Agent/Registrar or legally authorized escrow agent at or prior to the redemption date, and such notice shall be of no effect unless such moneys are so deposited on or prior to the redemption date. If such redemption is not effectuated, the Paying Agent/Registrar shall, within five days thereafter, give notice in the manner in which the notice of redemption was given that such moneys were not so received and shall rescind the redemption.

ALL BONDS OF THIS SERIES are issuable solely as fully registered Bonds, without interest coupons, in Authorized Denominations. As provided in the Bond Ordinance, this Bond may, at the request of the registered owner or the assignee or assignees hereof, be assigned, transferred, and exchanged for a like aggregate principal amount of fully registered Bonds, without interest coupons, payable to the

appropriate registered owner, assignee, or assignees, as the case may be, having the same maturity date, and bearing interest at the same rate, in Authorized Denominations as requested in writing by the appropriate registered owner, assignee, or assignees, as the case may be, upon surrender of this Bond to the Paying Agent/Registrar at its Designated Trust Office for cancellation, all in accordance with the form and procedures set forth in the Bond Ordinance. Among other requirements for such assignment and transfer, this Bond must be presented and surrendered to the Paying Agent/Registrar at its Designated Trust Office, together with proper instruments of assignment, in form and with guarantee of signatures satisfactory to the Paying Agent/Registrar, evidencing assignment of this Bond or any portion or portions hereof in an Authorized Denomination to the assignee or assignees in whose name or names this Bond or any such portion or portions hereof is or are to be transferred and registered. The form of Assignment printed or endorsed on this Bond may be executed by the registered owner to evidence the assignment hereof, but such method is not exclusive, and other instruments of assignment satisfactory to the Paying Agent/Registrar may be used to evidence the assignment of this Bond or any portion or portions hereof from time to time by the registered owner. The foregoing notwithstanding, in the case of the exchange of an assigned and transferred Bond or Bonds or any portion or portions thereof, such fees and charges of the Paying Agent/Registrar will be paid by the City. The one requesting such exchange shall pay the Paying Agent/Registrar's reasonable standard or customary fees and charges for exchanging any Bond or portion thereof. In any circumstance, any taxes or governmental charges required to be paid with respect thereto shall be paid by the one requesting such assignment, transfer, or exchange as a condition precedent to the exercise of such privilege. In any circumstance, neither the City nor the Paying Agent/Registrar shall be required (1) to make any transfer or exchange during a period beginning at the opening of business 30 days before the day of the first mailing of a notice of redemption of Bonds and ending at the close of business on the day of such mailing, or (2) to transfer or exchange any Bonds so selected for redemption when such redemption is scheduled to occur within 45 calendar days.

WHENEVER the beneficial ownership of this Bond is determined by a book entry at a securities depository for the Bonds, the foregoing requirements of holding, delivering or transferring this Bond shall be modified to require the appropriate person or entity to meet the requirements of the securities depository as to registering or transferring the book entry to produce the same effect.

IN THE EVENT any Paying Agent/Registrar for the Bonds is changed by the City, resigns, or otherwise ceases to act as such, the City has covenanted in the Bond Ordinance that it promptly will appoint a competent and legally qualified substitute therefor, and promptly will cause written notice thereof to be mailed to the registered owners of the Bonds.

IT IS HEREBY certified, recited and covenanted that this Bond has been duly and validly authorized, issued, and delivered; that all acts, conditions, and things required or proper to be performed, exist, and be done precedent to or in the authorization, issuance, and delivery of this Bond have been performed, existed, and been done in accordance with law; that this Bond is a direct obligation of said City, issued on the full faith and credit thereof; and that in accordance with the terms of the Bond Ordinance, annual ad valorem taxes sufficient to provide for the payment of the interest on and principal of this Bond, as such interest comes due and such principal matures, have been levied and ordered to be levied against all taxable property in said City, and have been pledged for such payment, within the limit prescribed by law.

BY BECOMING the registered owner of this Bond, the registered owner thereby acknowledges all of the terms and provisions of the Bond Ordinance, agrees to be bound by such terms and provisions, acknowledges that the Bond Ordinance is duly recorded and available for inspection in the official minutes and records of the City, and agrees that the terms and provisions of this Bond and the Bond Ordinance constitute a contract between each registered owner hereof and the City.

IN WITNESS WHEREOF, this Bond has been signed with the manual or facsimile signature of the Mayor of the City, attested by the manual or facsimile signature of the City Secretary, and the official seal of the City has been duly affixed to, or impressed, or placed in facsimile, on this Bond.

\_\_\_\_\_  
City Secretary

\_\_\_\_\_  
Mayor

(CITY SEAL)

FORM OF PAYING AGENT/REGISTRAR'S AUTHENTICATION CERTIFICATE

PAYING AGENT/REGISTRAR'S AUTHENTICATION CERTIFICATE

It is hereby certified that this Bond has been issued under the provisions of the proceedings adopted by the City as described in the text of this Bond; and that this Bond has been issued in exchange for or replacement of a Bond of an issue which originally was approved by the Attorney General of the State of Texas and registered by the Comptroller of Public Accounts of the State of Texas.

Dated: \_\_\_\_\_.

U.S. Bank Trust Company, National Association  
Dallas, Texas  
Paying Agent/Registrar

By: \_\_\_\_\_  
Authorized Representative

FORM OF COMPTROLLER'S CERTIFICATE

[ATTACHED TO BONDS NO. T-1 AND TR-1 UPON INITIAL DELIVERY THEREOF]

COMPTROLLER'S CERTIFICATE

OFFICE OF COMPTROLLER

§

REGISTER NO. \_\_\_\_\_

STATE OF TEXAS

§

I hereby certify that there is on file and of record in my office a true and correct copy of the opinion of the Attorney General of the State of Texas approving this Bond and that this Bond has been registered this day by me.

WITNESS MY HAND and seal of office at Austin, Texas this \_\_\_\_\_.

\_\_\_\_\_  
Comptroller of Public Accounts of the State of Texas

(SEAL)

FORM OF ASSIGNMENT

ASSIGNMENT

For value received, the undersigned hereby sells, assigns and transfers unto:

\_\_\_\_\_  
*Please insert Social Security or Taxpayer Identification Number of Transferee*

\_\_\_\_\_  
*Please print or type name and address, including zip code of Transferee*

the within Bond and all rights thereunder, and hereby irrevocably constitutes and appoints: \_\_\_\_\_, attorney, to register the transfer of the within Bond on the books kept for registration thereof, with full power of substitution in the premises.

Dated: \_\_\_\_\_.

Signature Guaranteed:

\_\_\_\_\_  
NOTICE: Signature(s) must be guaranteed by an eligible guarantor institution participating in a securities transfer association recognized signature guarantee program.

\_\_\_\_\_  
NOTICE: The signature above must correspond with the name of the registered owner as it appears upon the front of this Bond in every particular, without alteration or enlargement or any change whatsoever.

INSERTIONS FOR THE INITIAL BOND. The initial Bond shall be in the form set forth in paragraph (a) of this Form of Bond, except that:

i. immediately under the name of the Bond, the headings "INTEREST RATE" and "MATURITY DATE" shall both be completed with the words "As shown below" and "CUSIP NO. \_\_\_\_\_" shall be deleted.

ii the first paragraph shall be deleted and the following will be inserted:

"THE CITY OF ROANOKE, TEXAS, in Tarrant and Denton Counties, Texas (the "City"), being a political subdivision of the State of Texas, hereby promises to pay to the Registered Owner specified above or to the registered assignee hereof (either being hereinafter called the "registered owner") on the Maturity Dates, in the Principal Amounts and bearing interest at the per annum Interest Rates set forth in the following schedule:

<u>Maturity Date</u>	<u>Principal Amount</u>	<u>Interest Rate</u>
[ ]	[ ]	[ ]

The City promises to pay interest on the unpaid principal amount hereof (calculated on the basis of a 360-day year of twelve 30-day months) from the Delivery Date above at the respective Interest Rate per annum specified above. Interest is payable on [February/August] 15, 202[] and on each August 15 and February 15 thereafter to the date of payment of the Principal Amounts specified above, or the date of redemption prior to maturity; except, that if this Bond is required to be authenticated and the date of its authentication is later than the first Record Date (hereinafter defined), such principal amount shall bear interest from the interest payment date next preceding the date of authentication, unless such date of authentication is after any Record Date but on or before the next following interest payment date, in which case such principal amount shall bear interest from such next following interest payment date; provided, however, that if on the date of authentication hereof the interest on the Bond or Bonds, if any, for which this Bond is being exchanged is due but has not been paid, then this Bond shall bear interest from the date to which such interest has been paid in full."

iii. The initial Bond shall be numbered "T-1."



## AGENDA ITEM

TO: Mayor and City Council

SUBJECT: Zoning Board of Adjustment appointments

MEETING DATE: June 23, 2026

DEPARTMENT: City Secretary

---

### ITEM SUMMARY:

Consideration and action to appoint three (3) members to the Zoning Board of Adjustments for a term expiring June 2028.

### INFORMATION:

The Zoning Board of Adjustment has five members who serve staggered two-year terms with Place 1, Place 3, and Place 4 due for renewal in 2026.

Chair Victor Molaschi in Place 1 has expressed interest in continued service on the Zoning Board of Adjustment.

Member Lewis Rice in Place 3 has expressed interest in continued service on the Zoning Board of Adjustment.

Eric Heimbrecht in Place 4 currently serves on the Zoning Board of Adjustment as well as the Planning and Zoning Commission. He cannot continue to serve on both of these quasi-judicial boards and has chosen to continue his service on the Planning and Zoning Commission.

Place 4 will have a vacancy as of June 30, 2026.

Hector Ojeah has submitted an application for consideration for appointment to the Zoning Board of Adjustment.

### STAFF RECOMMENDATION:

### SPECIAL CONSIDERATION:

### FINANCIAL CONSIDERATION:



## AGENDA ITEM

### ATTACHMENTS:

1. Zoning Board of Adjustment - Hector Ojeah\_Redacted

# Zoning Board of Adjustment

To be eligible to serve on a board or commission, you must be a Roanoke resident for a minimum of twelve (12) months.

## **Meeting Time, Day and Location** \*

7:00 PM

Third (3rd) Thursday of each month

Roanoke City Hall

500 S. Oak Street

Roanoke, TX 76262

- Available to attend on specified day and time
- Unavailable to attend on specified day and time

Do you agree to the attendance requirements? \*

## **Roanoke Home Rule Charter**

### **Section 8.01 - Authority, composition and procedures.**

(5) Any member of a board, commission or committee who is absent from three (3) consecutive regular meetings, or twenty-five percent (25%) of regularly scheduled meetings during the twelve-month (12-month) period immediately preceding and including the absence in question, without explanation acceptable to a majority of the other members, shall, upon approval of the City Council forfeit his or her position on the board, commission, or committee.

- Yes
- No

Applicant First & Last Name \*

Hector Ojeah

Address \*

[REDACTED]

Home/Cell Phone \*

[REDACTED]

Email Address \*

[REDACTED]

### Eligibility

How long have you lived within the Roanoke City Limits? \*

26 Years

Are You Registered to Vote in Roanoke? \*

Yes

No

**Voter Registration (VUID) Number**

\*

You can obtain your VUID from the [Denton County Elections Administration](#) website.

██████████

**Occupation \***

Retired Building and Logistics Executive

**Work Experience Applicable to the board position to which you are applying. \***

Building Management with UPS

**Other Special Knowledge or Experience Applicable to the board position to which you are applying. \***

\*

Managing new building codes as part of my responsibility with UPS

**Previous Volunteer Experience (Church Civic, Youth, etc.) \***

Church Youth Ministry, Texas Motor Speedway Children Charity and Roanoke Economic and Development Corp

**Have you attended a meeting of the board/commission for which you have applied? \***

Yes

No



## AGENDA ITEM

TO: Mayor and City Council

SUBJECT: Amending Chapter 12 to add alternates to boards

MEETING DATE: June 23, 2026

DEPARTMENT: Planning

---

### **ITEM SUMMARY:**

Conduct a public hearing and consider approval on Ordinance No. 2026-126 Chapter 12, Article II, Division 3 and Division 4 to increase the number of alternate members for the Planning and Zoning Commission and the Zoning Board of Adjustment.

### **INFORMATION:**

The proposed ordinance amends the City's Code of Ordinances to add alternate members to the Planning and Zoning Commission and the Zoning Board of Adjustment. The addition of alternates is intended to help maintain quorum when regular members are absent, recused, or otherwise unable to participate, thereby reducing meeting cancellations, delays in hearing applications, and disruptions to the development review process.

The Planning & Zoning Board voted to recommend approval of the amendment in a 5-1 vote.

### **STAFF RECOMMENDATION:**

Staff recommends approval.

### **SPECIAL CONSIDERATION:**

### **FINANCIAL CONSIDERATION:**

### **ATTACHMENTS:**

1. Ordinance No. 2026-126 adding board alternates

**ORDINANCE NO. 2026-126**

**AN ORDINANCE OF THE CITY COUNCIL OF THE CITY OF ROANOKE, TEXAS, AMENDING CHAPTER 12, ARTICLE II, DIVISION 3 AND DIVISION 4 OF THE ROANOKE CODE OF ORDINANCES TO INCREASE THE NUMBER OF ALTERNATE MEMBERS FOR THE PLANNING AND ZONING COMMISSION AND THE ZONING BOARD OF ADJUSTMENT; PROVIDING FOR APPOINTMENTS; PROVIDING A SEVERABILITY CLAUSE; PROVIDING A REPEALER CLAUSE; AND PROVIDING AN EFFECTIVE DATE.**

**WHEREAS**, the City Council of the City of Roanoke, Texas, finds it in the public interest to ensure continuity, quorum availability, and efficient operation of its appointed boards and commissions; and

**WHEREAS**, the City Council desires to amend its Code of Ordinances to provide additional alternate members for both the Planning and Zoning Commission and the Zoning Board of Adjustment.

**NOW, THEREFORE, BE IT ORDAINED BY THE CITY COUNCIL OF THE CITY OF ROANOKE, TEXAS, THAT:**

**SECTION 1.  
FINDINGS INCORPORATED**

The findings set forth above are incorporated into the body of this Ordinance as if fully set forth herein.

**SECTION 2.**

Chapter 12, Article II, Division 3, Section 12.76(a), of the Code of Ordinances, City of Roanoke, Texas, entitled "Created; Membership; Officers; Rules & Bylaws" is hereby amended to read as follows:

**"Sec. 12.76. - Created; Membership; Officers; Rules & Bylaws.**

- a) There is created, in accordance with Chapter 211 of the Texas Local Government Code the "Planning and Zoning Commission," hereinafter sometimes referred to as the "Commission," which shall consist of at least seven (7) registered voters of the City of Roanoke. In addition, City Council may appoint two (2) alternate members to the Planning and Zoning Commission. Such alternate members shall be appointed in the same manner as regular members and shall serve at the pleasure of the City Council. Alternates may participate in Commission proceedings only when called upon to serve in the absence or disqualification of a regular member."

### **SECTION 3.**

Chapter 12, Article II, Division 4, Section 12.92, of the Code of Ordinances, City of Roanoke, Texas, entitled "Created" is hereby amended to read as follows:

#### **"Sec. 12.92. - Members; Terms of Office.**

- 1) The Board shall consist of five (5) members and shall operate in accordance with Sections 211.008 through 211.011 of the Texas Local Government Code, as amended.
- 2) The Board may include four (4) alternate members. Such alternate members shall be appointed in the same manner as regular members. Alternates may participate in Board proceedings only when called upon to serve in the absence or disqualification of a regular member.
- 3) The Board shall have the power to make the rules, regulations and bylaws for its own governance, with the approval of City Council, which shall conform as nearly as possible to those rules, regulations and bylaws governing the City Council, and the Board's rules, regulations and bylaws."

### **SECTION 4. SEVERABILITY CLAUSE**

It is hereby declared to be the intention of the City Council that the phrases, clauses, sentences, paragraphs and sections of this Ordinance are severable, and if any phrase, clause, sentence, paragraph or section of this Ordinance shall be declared unconstitutional by the valid judgment or decree of any court of competent jurisdiction, such unconstitutionality shall not affect any of the remaining phrases, clauses, sentences, paragraphs and sections of this Ordinance, since the same would have been enacted by the City Council without the incorporation of this Ordinance of any such unconstitutional phrase, clause, sentence, paragraph or section.

### **SECTION 5. REPEALER CLAUSE**

Any provision of any prior ordinance of the City whether codified or uncodified, which are in conflict with any provision of this Ordinance, are hereby repealed to the extent of the conflict, but all other provisions of the ordinances of the City whether codified or uncodified, which are not in conflict with the provisions of this Ordinance, shall remain in full force and effect.

**SECTION 6.  
EFFECTIVE DATE**

This Ordinance shall become effective immediately upon its passage and publication as required by law.

**PASSED, APPROVED AND ADOPTED** by the City Council of the City of Roanoke, Texas, on this June 23, 2026.

**APPROVED:**

\_\_\_\_\_  
Carl E. Gierisch, Jr., Mayor

**ATTEST:**

\_\_\_\_\_  
Lindsay Rawlinson, City Secretary

**APPROVED AS TO FORM:**

\_\_\_\_\_  
Jeff Moore, City Attorney